

## Excellent Integrated System Limited

Stocking Distributor

Click to view price, real time Inventory, Delivery & Lifecycle Information:

[Maxim Integrated](#)  
[MAX9516EVKIT+](#)

For any questions, you can email us directly:

[sales@integrated-circuit.com](mailto:sales@integrated-circuit.com)



# MAX9516 Evaluation Kit

Evaluates: MAX9516

## General Description

The MAX9516 evaluation kit (EV kit) is a fully assembled and tested surface-mount printed-circuit board (PCB) that evaluates the MAX9516 video IC. The MAX9516 amplifies standard-definition video signals and sets the output video black level near ground, while consuming minimal power. The MAX9516 has an internal reconstruction filter, provides an internal fixed gain of 8V/V, accepts a full-scale video input signal of 0.25V<sub>P-P</sub> (nominal), and provides an output full-scale video signal of 2V<sub>P-P</sub> (nominal).

The MAX9516 EV kit video input signal is configured for both DC- and AC-coupled operation. The EV kit video input is terminated with a 75Ω resistor to ground and the output is back terminated with a series 75Ω resistor. The EV kit also includes an output LOAD signal, which indicates when a valid output load is present. The EV kit operates from a single 1.7V to 2.625V DC power supply.

## Features

- ◆ Single 1.7V to 2.625V Supply Operation
- ◆ DC-Coupled Input with Option for AC-Coupling
- ◆ DC-Coupled Output
- ◆ Video Load Detect Indicator
- ◆ Internal Preset 8V/V Gain
- ◆ Surface-Mount Components
- ◆ Fully Assembled and Tested
- ◆ Lead Free and RoHS Compliant

## Component List

DESIGNATION	QTY	PART DESCRIPTION
C1, C3	2	0.1μF ±10%, 25V X7R ceramic capacitors (0603) TDK C1608X7R1E104K
C2	1	10μF ±20%, 6.3V X5R ceramic capacitor (0805) TDK C2012X5R0J106M
C4, C5	2	1μF ±10%, 10V X5R ceramic capacitors (0603) TDK C1608X5R1A105K
IN, OUT	2	75Ω BNC PCB-mount jack connectors
JU1	1	3-pin header
R1	1	0Ω ±5% resistor (0603)
R2, R3	2	75Ω ±1% resistors (0603)
R4	0	Not installed, resistor (0603)
TP1	1	PC mini red test point
U1	1	MAX9516ALB+ (10-pin μDFN, 2mm x 2mm)
—	1	Shunt (JU1)
—	1	PCB: MAX9516 Evaluation Kit+

## Ordering Information

PART	TYPE
MAX9516EVKIT+	EV Kit

+Denotes lead-free and RoHS-compliant

## Component Supplier

SUPPLIER	PHONE	WEBSITE
TDK Corp.	847-803-6100	www.component.tdk.com

**Note:** Indicate that you are using the MAX9516 when contacting this component supplier.

# MAX9516 Evaluation Kit

## Quick Start

### Recommended Equipment

- 1.7V to 2.625V, 500mA DC power supply (VDD)
- Video signal generator
- Video measurement equipment (e.g., Tektronix VM-700T)
- Oscilloscope

### Procedure

The MAX9516 EV kit is fully assembled and tested. Follow the steps below to verify board operation.

**Caution: Do not turn on the power supply until all connections are completed.**

- 1) Verify that a shunt is installed across pins 1-2 of jumper JU1 (EV kit enabled).
- 2) Connect the power supply ground to the GND pad on the EV kit.
- 3) Connect the power supply positive terminal to the VDD pad on the EV kit.
- 4) Connect the output of the video signal generator to the IN BNC connector on the EV kit. The video signal must be biased such that the sync tip is at ground.
- 5) Connect the OUT BNC connector on the EV kit to the input of the video measurement equipment.
- 6) Connect the scope probe to the LOAD pad and the ground lead of the scope probe to the GND pad.
- 7) Set the video signal generator for the desired video input signal. This signal must contain sync information.
- 8) Turn on the power supply and set it to 1.8V.
- 9) Enable the video signal generator.
- 10) Verify that the voltage level at LOAD is equal to 1.8V.
- 11) Analyze the video output signal with the video measurement equipment.

## Detailed Description

The MAX9516 evaluation kit is a fully assembled and tested surface-mount PCB that evaluates the MAX9516 video IC. The MAX9516 amplifies and sets the output video black level near ground for standard-definition video signals, while consuming minimal power. The EV kit operates from a single 1.7V to 2.625V power supply that can supply up to 20mA.

The MAX9516 IC has an additional internal reconstruc-

tion filter that smooths the steps and reduces the spikes on the video signal from the video digital-to-analog converter (DAC). The reconstruction filter typically has 3dB attenuation at 10MHz, 46dB attenuation at 27MHz, and  $\pm 1$ dB passband flatness to 8.1MHz.

The MAX9516 provides an internal fixed 8V/V gain. The EV kit accepts a full-scale video input signal of 0.25V<sub>p-p</sub> (nominal), and provides an output full-scale video signal of 2V<sub>p-p</sub> (nominal).

The MAX9516 EV kit video input signal is by default configured for DC-coupled operation. The MAX9516 has a transparent input sync-tip clamp, allowing AC-coupling of input signals with different DC biases. The MAX9516 video input on the EV kit can also be configured for AC-coupling operation by removing resistor R1. The EV kit input is terminated to ground by resistor R2 and the output is back terminated by resistor R3. The MAX9516 EV kit also features a LOAD signal output pad, which indicates when a valid output load is present. An additional VLOGIC pad and pullup resistor R4 is included for a future product.

### Jumper Selection and Other Configurations

#### Shutdown Mode ( $\overline{\text{SHDN}}$ )

Jumper JU1 controls the MAX9516 shutdown mode ( $\overline{\text{SHDN}}$ ). The shutdown mode turns off the sync-tip clamp, filter, amplifier, charge pump, and internal linear regulator, thus reducing the IC's quiescent supply current to 10nA (typ). See Table 1 for jumper JU1 selection.

**Table 1. JU1 Jumper Selection ( $\overline{\text{SHDN}}$ )**

SHUNT POSITION	SHDN PIN	EV KIT FUNCTION
1-2	Connected to VDD	Enabled
2-3	Connected to GND	Disabled

#### Load Detect Indicator

The MAX9516 EV kit provides a LOAD output pad that indicates when a valid video load is present at OUT. The LOAD signal is a logic-high when a valid video load is present at OUT, and a logic-low when a valid video load is not present at OUT.

#### AC-Coupled Input

The default setting of the MAX9516 EV kit is set for a DC-coupled input. However, the kit can be configured for an AC-coupled input by removing resistor R1.

## MAX9516 Evaluation Kit

Evaluates: MAX9516

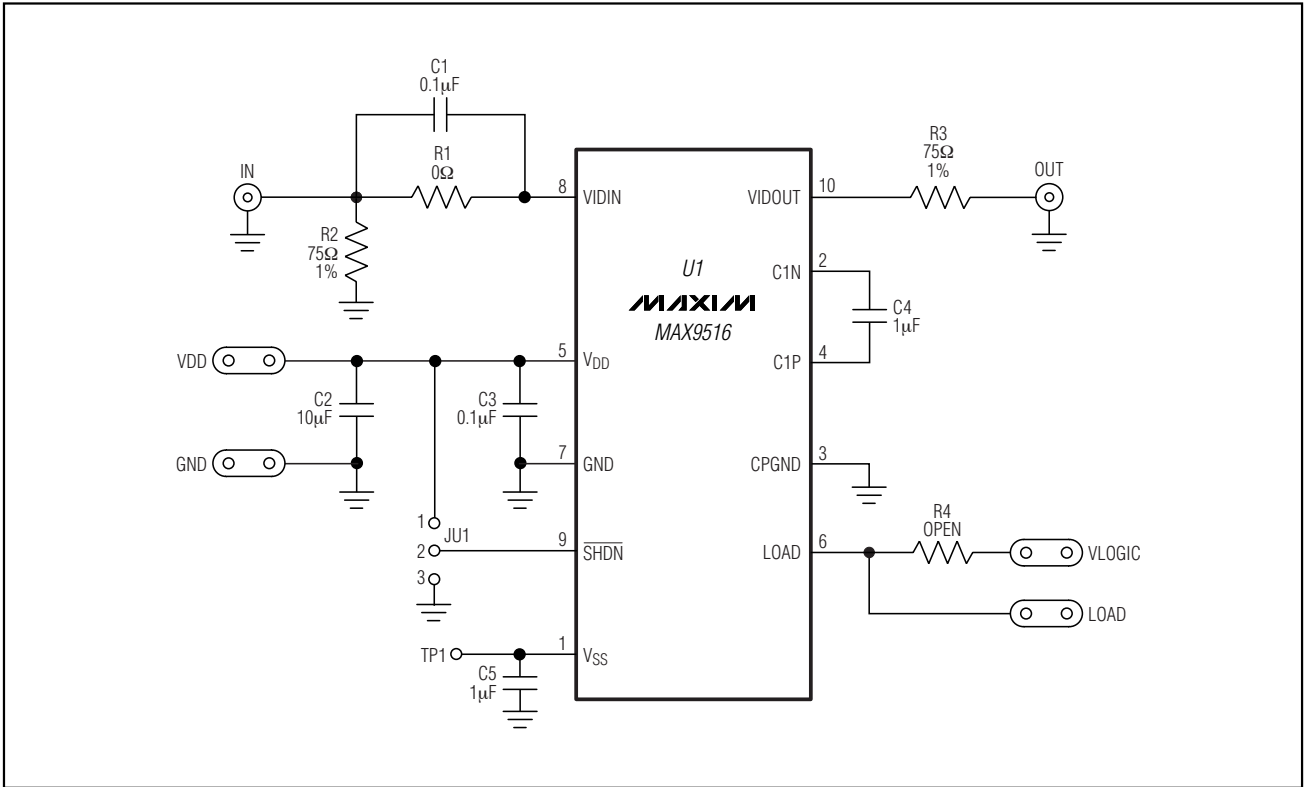

Figure 1. MAX9516 EV Kit Schematic

# MAX9516 Evaluation Kit

**Evaluates: MAX9516**

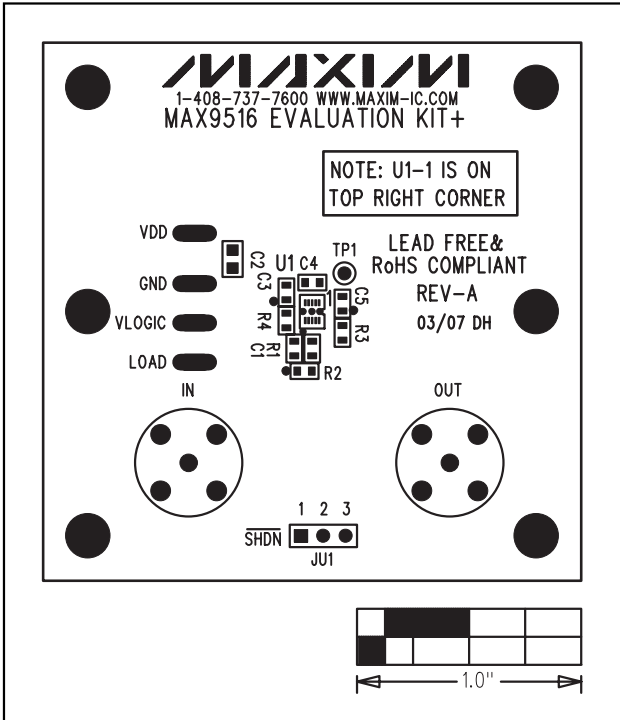

Figure 2. MAX9516 EV Kit Component Placement Guide—Component Side

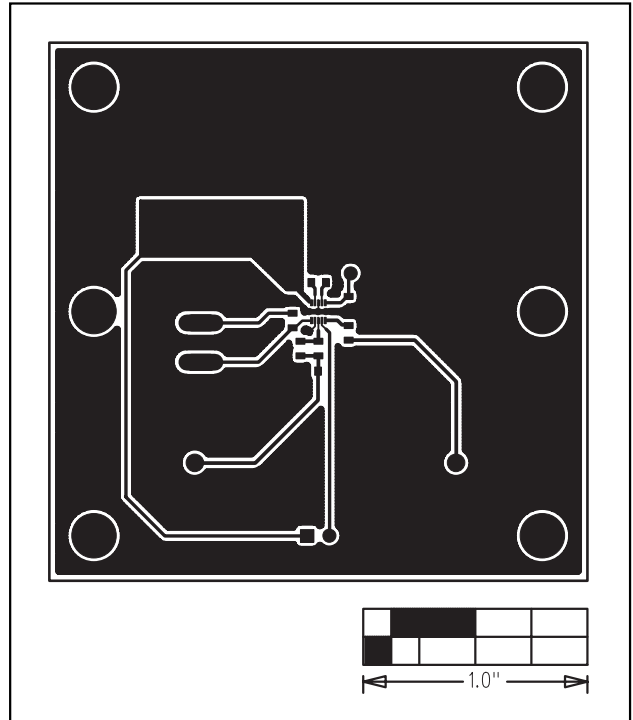

Figure 3. MAX9516 EV Kit PCB Layout—Component Side

## MAX9516 Evaluation Kit

**Evaluates: MAX9516**

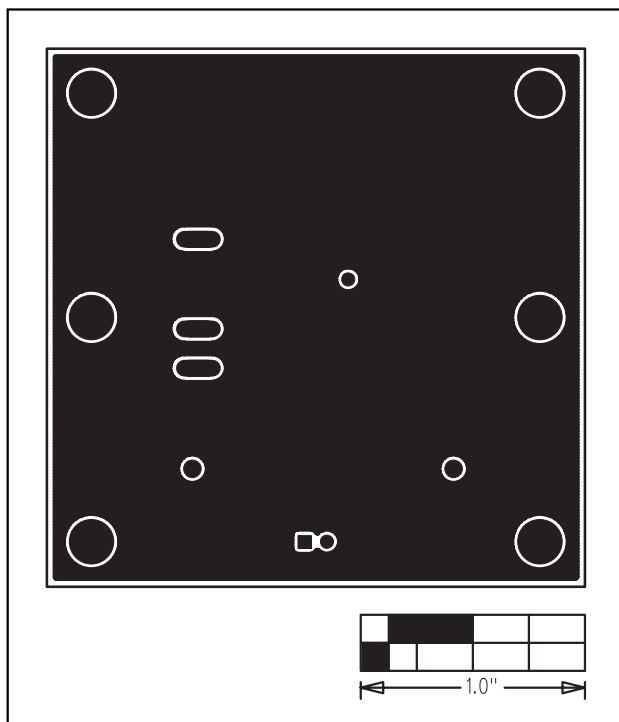

Figure 4. MAX9516 EV Kit PCB Layout—Solder Side

Maxim cannot assume responsibility for use of any circuitry other than circuitry entirely embodied in a Maxim product. No circuit patent licenses are implied. Maxim reserves the right to change the circuitry and specifications without notice at any time.

**Maxim Integrated Products, 120 San Gabriel Drive, Sunnyvale, CA 94086 408-737-7600** \_\_\_\_\_ **5**