

Excellent Integrated System Limited

Stocking Distributor

Click to view price, real time Inventory, Delivery & Lifecycle Information:

[Advanced Thermal Solutions Inc.](#)
[ATS-TMDK-96](#)

For any questions, you can email us directly:
sales@integrated-circuit.com

Ultra High Performance BGA Cooling Solutions w/ maxiGRIP™ Attachment*

DIGI-KEY PART # ATS1071-ND

ATS PART # ATS-51300K-C2-R0

Features & Benefits

maxiFLOW™ design features a low profile, spread fin array that maximizes surface area for more effective convection (air) cooling

maxiGRIP™ attachment applies steady, even pressure to the component and does not require holes in the PCB

Meets Telcordia GR-63-Core Office Vibration; ETSI 300 019 Transportation Vibration; and MIL-STD-810 Shock and Unpackaged Drop Testing standards

Comes preassembled with high performance, phase changing, thermal interface material

Designed for low profile components from 1.5 to 2.99mm

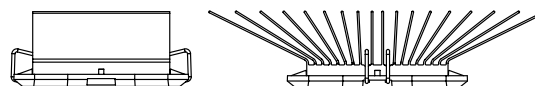
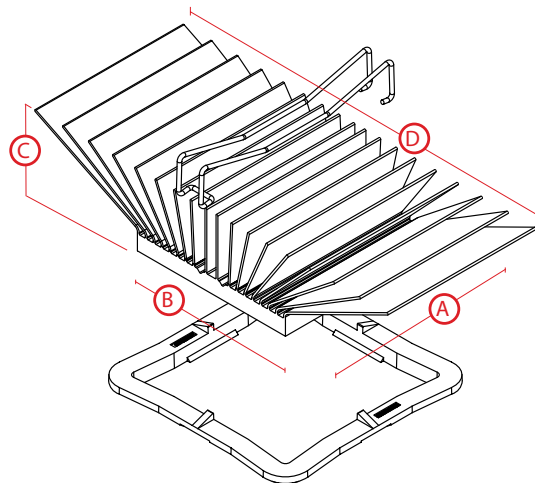

Thermal Performance Table

AIR VELOCITY		THERMAL RESISTANCE	
FT/MIN	M/S	°C/W (UNDUCTED)	°C/W (DUCTED)
200	1.0	4.3	3.4
300	1.5	3.5	
400	2.0	3	
500	2.5	2.7	
600	3.0	2.5	
700	3.5	2.3	
800	4.0	2.2	

Product Details†

DIMENSION A	DIMENSION B	DIMENSION C§	DIMENSION D	TIM†	FINISH
30	30	14.5	53.34	C1100F	BLACK- ANODIZED

For further technical information, please contact Advanced Thermal Solutions, Inc. at **1-781-769-2800** or **www.qats.com**

* RoHS Compliant

† TIM = Thermal Interface Material

‡ Dimensions are measured in millimeters

◆ Dimensions A & B refer to component size

§ Dimension C = the height of the heat sink shown above and does not include the height of the attachment method



ATS ADVANCED THERMAL SOLUTIONS, INC.
 Innovations in Thermal Management®



To place an order, please visit **www.digikey.com**