

## Excellent Integrated System Limited

Stocking Distributor

Click to view price, real time Inventory, Delivery & Lifecycle Information:

[Vishay Semiconductor/Diodes Division](#)  
[MBR1060/45](#)

For any questions, you can email us directly:

[sales@integrated-circuit.com](mailto:sales@integrated-circuit.com)

# MBR1035 THRU MBR1060

## SCHOTTKY RECTIFIER

Reverse Voltage - 35 to 60 Volts Forward Current - 10.0 Amperes

### TO-220AC

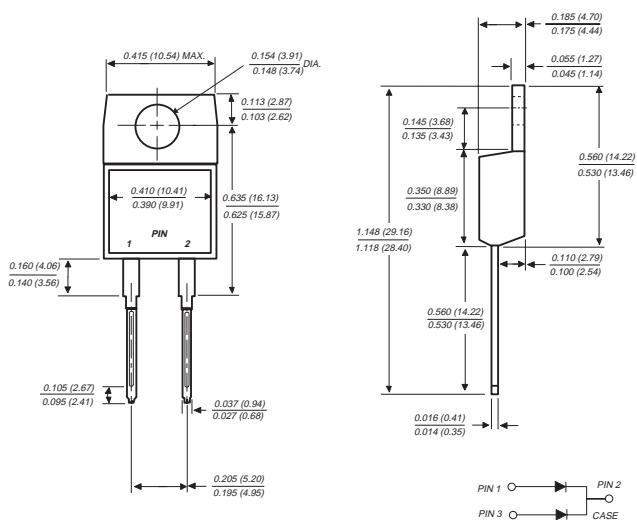

Dimensions in inches and (millimeters)

### FEATURES

- ◆ Plastic package has Underwriters Laboratory Flammability Classifications 94V-0
- ◆ Metal silicon junction, majority carrier conduction
- ◆ Low power loss, high efficiency
- ◆ High current capability, low forward voltage drop
- ◆ High surge capability
- ◆ For use in low voltage, high frequency inverters, free wheeling, and polarity protection applications
- ◆ Guardring for overvoltage protection
- ◆ High temperature soldering guaranteed: 250°C/10 seconds, 0.25" (6.35mm) from case



### MECHANICAL DATA

**Case:** JEDEC TO-220AC molded plastic body  
**Terminals:** Leads solderable per MIL-STD-750, Method 2026  
**Polarity:** As marked  
**Mounting Position:** Any  
**Mounting Torque:** 5 in. - lbs. max.  
**Weight:** 0.08 ounces, 1.81 grams

### MAXIMUM RATINGS AND ELECTRICAL CHARACTERISTICS

Ratings at 25°C ambient temperature unless otherwise specified.

	SYMBOLS	MBR1035	MBR1045	MBR1050	MBR1060	UNITS
Maximum repetitive peak reverse voltage	V <sub>RRM</sub>	35	45	50	60	Volts
Maximum working peak reverse voltage	V <sub>RWM</sub>	35	45	50	60	Volts
Maximum DC blocking voltage	V <sub>DC</sub>	35	45	50	60	Volts
Maximum average forward rectified current (SEE FIG. 1)	I <sub>(AV)</sub>	10.0				Amps
Peak repetitive forward current at T <sub>C</sub> =135°C (square wave 20 KHz)	I <sub>FRM</sub>	20.0				Amps
Peak forward surge current 8.3ms single half sine-wave superimposed on rated load (JEDEC Method)	I <sub>FSM</sub>	150.0				Amps
Peak repetitive reverse surge current (NOTE 1)	I <sub>RRM</sub>	1.0		0.5		Amps
Voltage rate of change (rated V <sub>R</sub> )	dv/dt	10,000				V/μs
Maximum instantaneous forward voltage at (NOTE 2) I <sub>F</sub> =10A, T <sub>C</sub> =25°C I <sub>F</sub> =10A, T <sub>C</sub> =125°C I <sub>F</sub> =20A, T <sub>C</sub> =25°C I <sub>F</sub> =20A, T <sub>C</sub> =125°C	V <sub>F</sub>	- 0.57 0.84 0.72		0.80 0.70 0.95 0.85		Volts
Maximum instantaneous reverse current at rated DC blocking voltage T <sub>C</sub> = 25°C (NOTE 2) T <sub>C</sub> =125°C	I <sub>R</sub>		0.10 15.0			mA
Maximum thermal resistance, junction to case	R <sub>θJC</sub>	2.0				°C/W
Operating junction temperature range	T <sub>J</sub>	-65 to +150				°C
Storage temperature range	T <sub>STG</sub>	-65 to +175				°C

**NOTES:**

- (1) 2.0μs pulse width, f=1.0 KHz  
 (2) Pulse test: 300μs pulse width, 1% duty cycle

**RATINGS AND CHARACTERISTIC CURVES MBR1035 THRU MBR1060**

