

Excellent Integrated System Limited

Stocking Distributor

Click to view price, real time Inventory, Delivery & Lifecycle Information:

[Texas Instruments](#)
[TLE4275QKTTRQ1](#)

For any questions, you can email us directly:

sales@integrated-circuit.com

TLE4275-Q1 5-V Low-Dropout Voltage Regulator

1 Features

- Qualified for Automotive Applications
- Output Voltage 5 V ± 2%
- Very Low Current Consumption
- Power-On and Undervoltage Reset
- Reset Low-Level Output Voltage < 1 V
- Very Low Dropout Voltage
- Short-Circuit Proof
- Reverse-Polarity Proof

2 Applications

- Qualified for Automotive Applications
- Cluster
- Body Control Modules
- Heating Ventilation and Air Conditioning (HVAC)

3 Description

The TLE4275-Q1 is a monolithic integrated low-dropout voltage regulator offered in a 5-pin TO package. The device regulates an input voltage up to 45 V to $V_{OUT} = 5\text{ V}$ (typical). The device can drive loads up to 450 mA and is short-circuit proof. At overtemperature, the incorporated temperature protection turns off the TLE4275-Q1. The device generates a reset signal for an output voltage, $V_{OUT,rt}$, of 4.65 V (typical). By the use of an external delay capacitor, one can program the reset delay time.

The input capacitor, C_{IN} , compensates for line fluctuation. Using a resistor of approximately 1 Ω in series with C_{IN} dampens the oscillation of input inductance and input capacitance. The output capacitor, C_{OUT} , stabilizes the regulation circuit. The specification for stability is at $C_{OUT} \geq 22\ \mu\text{F}$ and $\text{ESR} \leq 5\ \Omega$, within the operating temperature range. Stability for electrolytic capacitors specifically is at $C_{OUT} \geq 68\ \mu\text{F}$ within the operating temperature range. See the application report on low-temperature stability, [SLVA501](#), for further details.

The control amplifier compares a reference voltage to a voltage that is proportional to the output voltage and drives the base of the series transistor through a buffer. Saturation control as a function of the load current prevents any oversaturation of the power element. The device also incorporates a number of internal circuits for protection against: *overload*, *overtemperature*, and *reverse polarity*.

Device Information⁽¹⁾

| PART NUMBER | PACKAGE | BODY SIZE (NOM) |
|-------------|------------------|--------------------|
| TLE4275-Q1 | DDPAK/TO-263 (5) | 10.16 mm × 8.42 mm |
| | TO-252 (5) | 6.10 mm × 6.60 mm |
| | HTSSOP (20) | 6.50 mm × 4.40 mm |

(1) For all available packages, see the orderable addendum at the end of the data sheet.

4 Typical Application

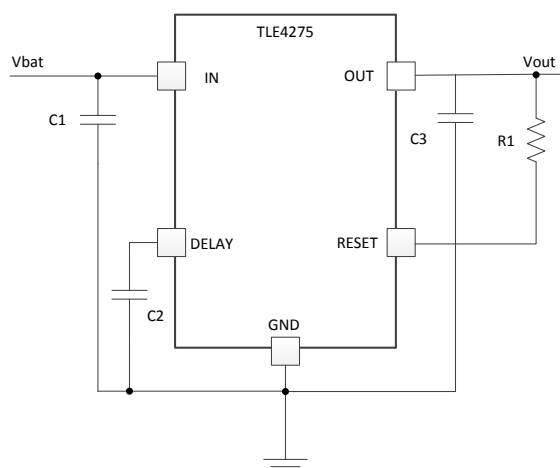

TLE4275-Q1

SLVS6471 – AUGUST 2006 – REVISED NOVEMBER 2014

www.ti.com

Table of Contents

| | | | |
|--|-----------|--|-----------|
| 1 Features | 1 | 9.2 Functional Block Diagram | 11 |
| 2 Applications | 1 | 9.3 Feature Description | 12 |
| 3 Description | 1 | 9.4 Device Functional Modes | 12 |
| 4 Typical Application | 1 | 10 Application and Implementation | 13 |
| 5 Revision History | 2 | 10.1 Application Information | 13 |
| 6 Pin Configuration and Functions | 3 | 10.2 Typical Application | 13 |
| 7 Specifications | 4 | 11 Power Supply Recommendations | 15 |
| 7.1 Absolute Maximum Ratings | 4 | 12 Layout | 15 |
| 7.2 ESD Ratings | 4 | 12.1 Layout Guidelines | 15 |
| 7.3 Recommended Operating Conditions | 4 | 12.2 Layout Example | 15 |
| 7.4 Thermal Information | 4 | 13 Device and Documentation Support | 16 |
| 7.5 Electrical Characteristics | 5 | 13.1 Documentation Support | 16 |
| 7.6 Switching Characteristics | 5 | 13.2 Trademarks | 16 |
| 7.7 Typical Characteristics | 7 | 13.3 Electrostatic Discharge Caution | 16 |
| 8 Parameter Measurement Information | 10 | 13.4 Glossary | 16 |
| 9 Detailed Description | 11 | 14 Mechanical, Packaging, and Orderable Information | 16 |
| 9.1 Overview | 11 | | |

5 Revision History

| Changes from Revision H (March 2013) to Revision I | Page |
|--|-------------|
| • Added <i>Applications, Pin Configuration and Functions</i> section, <i>Handling Rating</i> table, <i>Feature Description</i> section, <i>Device Functional Modes</i> , <i>Application and Implementation</i> section, <i>Power Supply Recommendations</i> section, <i>Layout</i> section, <i>Device and Documentation Support</i> section, and <i>Mechanical, Packaging, and Orderable Information</i> section | 1 |
| • Changed KTT values in <i>Thermal Information</i> table | 4 |

| Changes from Revision G (January 2013) to Revision H | Page |
|--|-------------|
| • Deleted row for θ_{JA} from <i>Absolute Maximum Ratings</i> table | 4 |

| Changes from Revision F (May 2011) to Revision G | Page |
|---|-------------|
| • Updated <i>Pin Functions</i> table with PWP package pin information. | 3 |

6 Pin Configuration and Functions

KTU Package
5-Pin DDPAK/TO-263
Top View

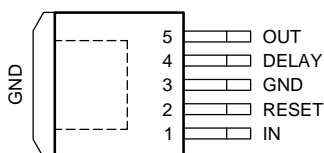

KVU Package
5-Pin TO-252
Top View

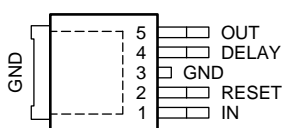

PWP Package
20-Pin HTSSOP With Exposed Thermal Pad
Top View

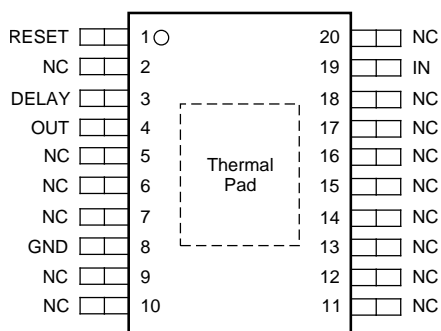

Pin Functions

| NAME | PIN NO. | | | TYPE | DESCRIPTION |
|-------|---------|----|---------------------|------|---|
| | KT | KV | PWP | | |
| | DELAY | 4 | 4 | | |
| GND | 3 | 3 | 8 | O | Ground. Internally connected to heatsink |
| IN | 1 | 1 | 19 | I | Input. Connect to ground as close to device as possible, through a ceramic capacitor. |
| NC | — | — | 2, 5–7, 9–11, 8, 20 | — | Not connected |
| OUT | 5 | 5 | 4 | O | Output. Connect to ground with $\geq 22\text{-}\mu\text{F}$ capacitor, ESR $< 5\ \Omega$ at 10 kHz. |
| RESET | 2 | 2 | 1 | I | Reset output. Open-collector output |

TLE4275-Q1

SLVS6471 – AUGUST 2006 – REVISED NOVEMBER 2014

www.ti.com

7 Specifications

7.1 Absolute Maximum Ratings⁽¹⁾

over operating free-air temperature range (unless otherwise noted)

| | | | MIN | MAX | UNIT |
|------------------|------------------------------------|-------|------|-----|------|
| V _I | Input voltage range ⁽²⁾ | IN | -42 | 45 | V |
| | | DELAY | -0.3 | 7 | |
| V _O | Output voltage range | OUT | -1 | 16 | V |
| | | RESET | -0.3 | 25 | |
| I _I | Input current | DELAY | | ±2 | mA |
| I _O | Output current | RESET | | ±5 | mA |
| T _J | Operating junction temperature | | -40 | 150 | °C |
| T _{stg} | Storage temperature | | -65 | 150 | °C |

- (1) Stresses beyond those listed under *Absolute Maximum Ratings* may cause permanent damage to the device. These are stress ratings only, and functional operation of the device at these or any other conditions beyond those indicated under *Recommended Operating Conditions* is not implied. Exposure to absolute-maximum-rated conditions for extended periods may affect device reliability.
- (2) All voltage values are with respect to the network ground terminal.

7.2 ESD Ratings

| | | | VALUE | UNIT |
|--------------------|-------------------------|---|-------|------|
| V _(ESD) | Electrostatic discharge | Human body model (HBM), per AEC Q100-002 ⁽¹⁾ | 6000 | V |
| | | Machine model (MM) ⁽²⁾ | 400 | |

- (1) AEC Q100-002 indicates HBM stressing is done in accordance with the ANSI/ESDA/JEDEC JS-001 specification.
- (2) MM ESD rating tested per JESD22-A115.

7.3 Recommended Operating Conditions

over operating free-air temperature range (unless otherwise noted)

| | | | MIN | MAX | UNIT |
|----------------|----------------------|--|-----|-----|------|
| V _I | Input voltage | | 5.5 | 42 | V |
| T _J | Junction temperature | | -40 | 150 | °C |

7.4 Thermal Information

| THERMAL METRIC ⁽¹⁾ | TLE4275-Q1 | | | UNIT | |
|-------------------------------|--|--------|---------|------|------|
| | KTT | KVU | PWP | | |
| | 5 PINS | 5 PINS | 20 PINS | | |
| R _{θJA} | Junction-to-ambient thermal resistance | 32.8 | 40.3 | 39.3 | °C/W |
| R _{θJC(top)} | Junction-to-case (top) thermal resistance | 38.0 | 31.8 | 22.7 | |
| R _{θJB} | Junction-to-board thermal resistance | 5.3 | 17.2 | 19.1 | |
| ψ _{JT} | Junction-to-top characterization parameter | 6.3 | 2.8 | 0.6 | |
| ψ _{JB} | Junction-to-board characterization parameter | 5.4 | 17.1 | 18.9 | |
| R _{θJC(bot)} | Junction-to-case (bottom) thermal resistance | 0.8 | 0.7 | 1.5 | |

- (1) For more information about traditional and new thermal metrics, see the *IC Package Thermal Metrics* application report (SPRA953).

7.5 Electrical Characteristics

over recommended operating free-air temperature range, $V_I = 13.5\text{ V}$, $T_J = -40^\circ\text{C}$ to 150°C (unless otherwise noted) (see Figure 18)

| PARAMETER | TEST CONDITIONS | MIN | TYP | MAX | UNIT |
|--|--|-----------------------------|------|-----|---------------|
| V_O Output voltage | $I_O = 5\text{ mA}$ to 400 mA , $V_I = 6\text{ V}$ to 28 V | 4.9 | 5 | 5.1 | V |
| | $I_O = 5\text{ mA}$ to 200 mA , $V_I = 6\text{ V}$ to 40 V | 4.9 | 5 | 5.1 | |
| I_O Output current limit | | 450 | 700 | 950 | mA |
| I_q Current consumption, $I_q = I_I - I_O$ | $I_O = 1\text{ mA}$ | $T_J = 25^\circ\text{C}$ | 150 | 200 | μA |
| | | $T_J \leq 85^\circ\text{C}$ | 150 | 220 | |
| | $I_O = 250\text{ mA}$ | | 5 | 10 | mA |
| | $I_O = 400\text{ mA}$ | | 12 | 22 | |
| V_{DO} Dropout voltage ⁽¹⁾ | $I_O = 300\text{ mA}$, $V_{do} = V_I - V_O$ | | 250 | 500 | mV |
| Load regulation | $I_O = 5\text{ mA}$ to 400 mA | | 15 | 30 | mV |
| Line regulation | $\Delta V_I = 8\text{ V}$ to 32 V , $I_O = 5\text{ mA}$ | -15 | 5 | 15 | mV |
| PSRR Power-supply ripple rejection | $f_r = 100\text{ Hz}$, $V_r = 0.5\text{ V}_{pp}$ | | 60 | | dB |
| $\frac{\Delta V_o}{\Delta T}$ Temperature output-voltage drift | | | 0.5 | | mV/K |
| $V_{O,rt}$ RESET switching threshold | | 4.5 | 4.65 | 4.8 | V |
| V_{ROL} RESET output low voltage | $R_{ext} \geq 5\text{ k}\Omega$, $V_O > 1\text{ V}$ | | 0.2 | 0.4 | V |
| I_{ROH} RESET output leakage current | $V_{ROH} = 5\text{ V}$ | | 0 | 10 | μA |
| $I_{D,c}$ RESET charging current | $V_D = 1\text{ V}$ | 3 | 5.5 | 9 | μA |
| V_{DU} RESET upper timing threshold | | 1.5 | 1.8 | 2.2 | V |
| V_{DRL} RESET lower timing threshold | | 0.2 | 0.4 | 0.7 | V |

(1) Measured when the output voltage V_O has dropped 100 mV from the nominal value obtained at $V_I = 13.5\text{ V}$

7.6 Switching Characteristics

over operating free-air temperature range (unless otherwise noted) (see Figure 1)

| PARAMETER | TEST CONDITIONS | MIN | TYP | MAX | UNIT |
|------------------------------|----------------------|-----|-----|-----|---------------|
| t_{rd} RESET delay time | $C_D = 47\text{ nF}$ | 10 | 16 | 22 | ms |
| t_{rr} RESET reaction time | $C_D = 47\text{ nF}$ | | 0.5 | 2 | μs |

TLE4275-Q1

SLVS6471 –AUGUST 2006–REVISED NOVEMBER 2014

www.ti.com

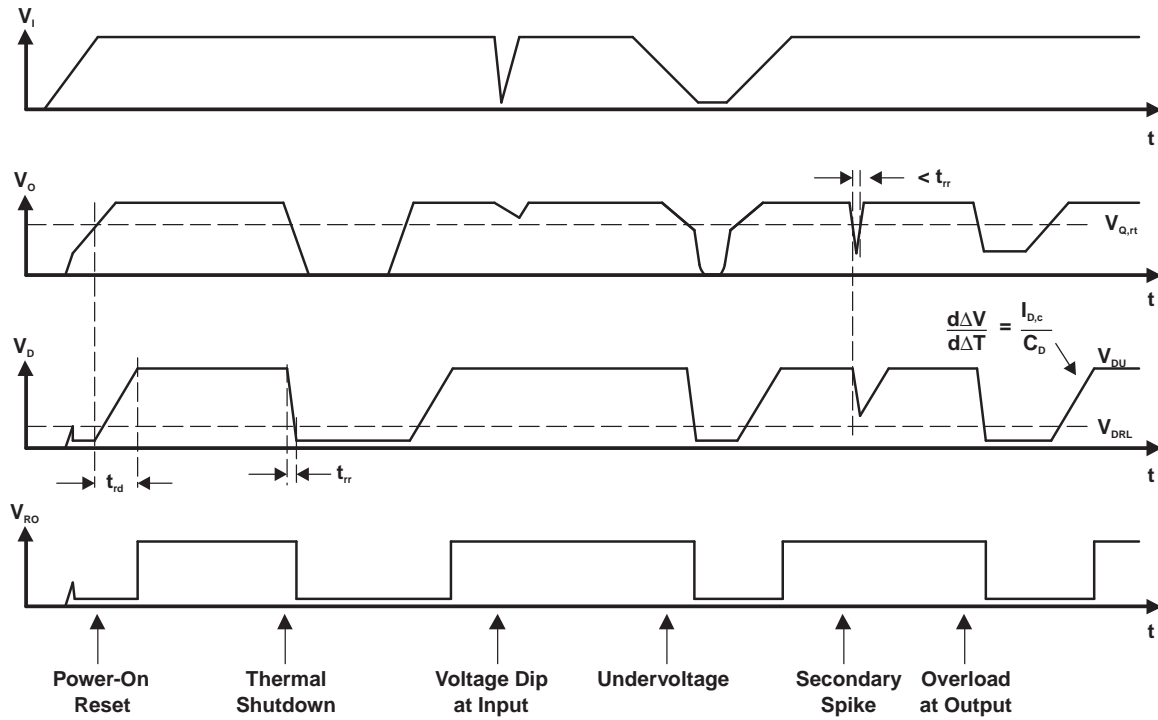

Figure 1. Reset Timing Diagram

7.7 Typical Characteristics

At $T_A = 25^\circ\text{C}$

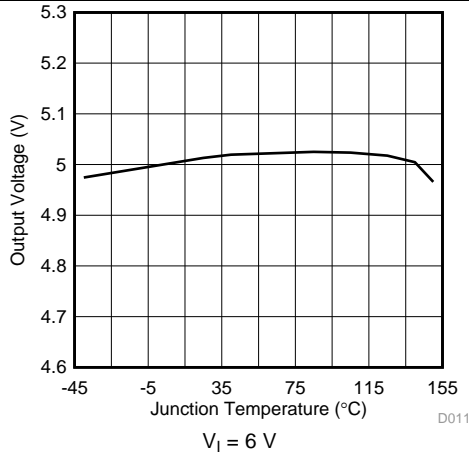

Figure 2. Output Voltage vs Junction Temperature

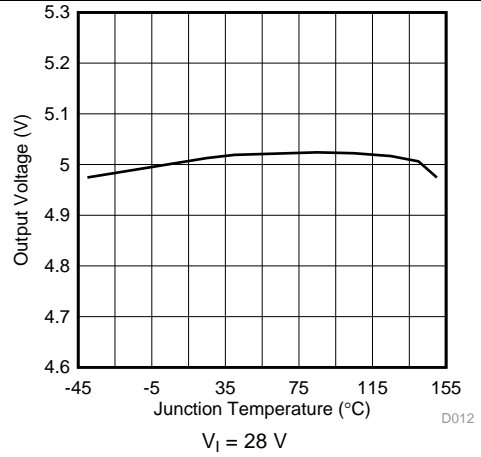

Figure 3. Output Voltage vs Junction Temperature

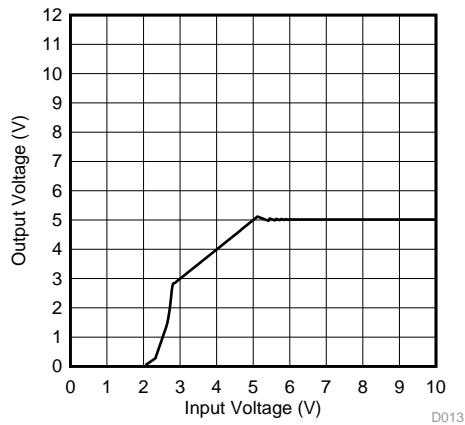

Figure 4. Output Voltage vs Input Voltage

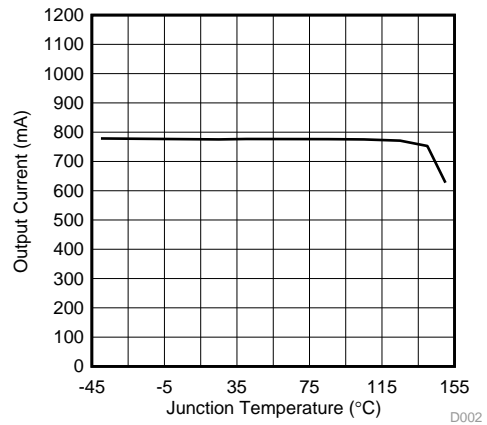

Figure 5. Output Current vs Junction Temperature

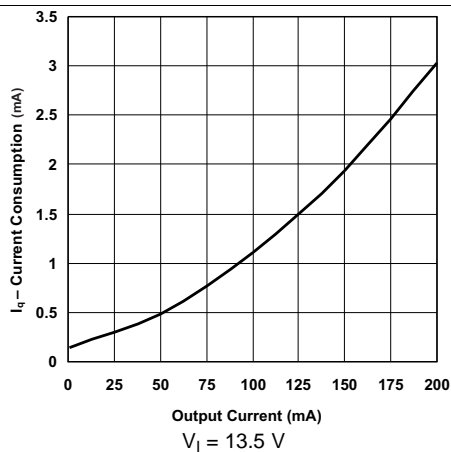

Figure 6. Current Consumption vs Output Current

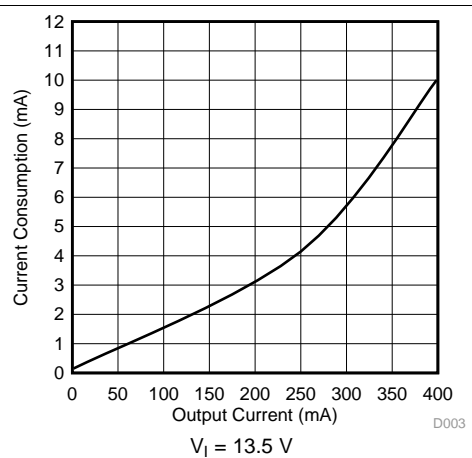

Figure 7. Current Consumption vs Output Current

TLE4275-Q1

SLVS6471 – AUGUST 2006 – REVISED NOVEMBER 2014

www.ti.com

Typical Characteristics (continued)

At $T_A = 25^\circ\text{C}$

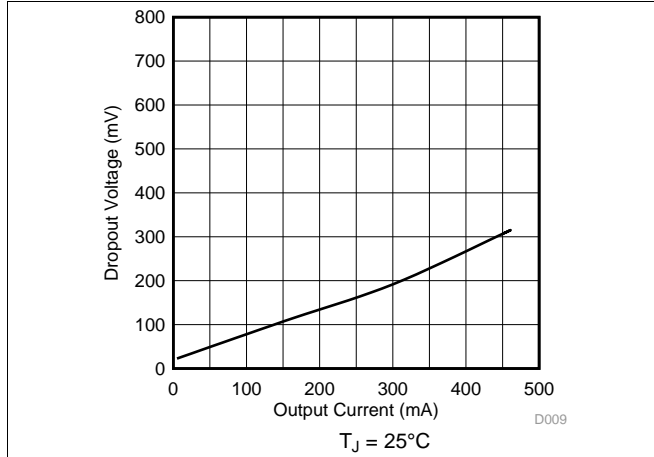

Figure 8. Dropout Voltage (V_{do}) vs Output Current

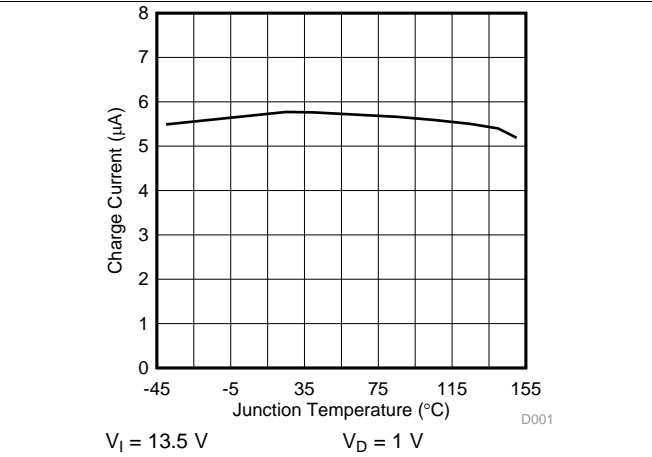

Figure 9. Charge Current ($I_{D,C}$) vs Junction Temperature

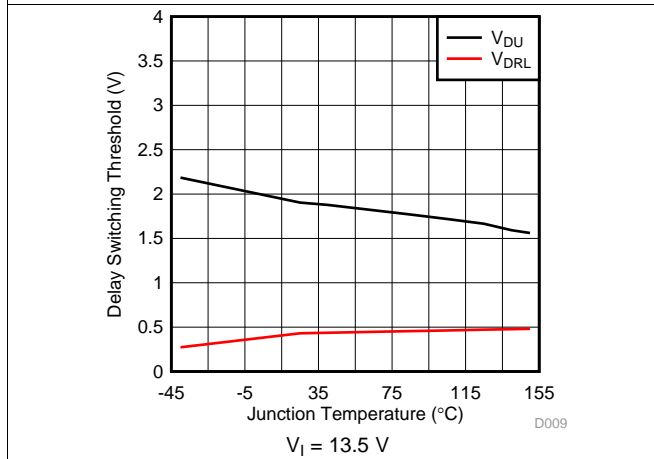

Figure 10. Delay Switching Threshold vs Junction Temperature

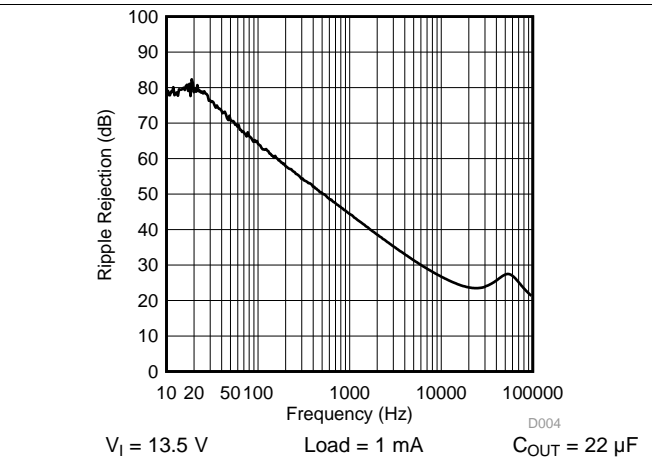

Figure 11. Power-Supply Ripple Rejection vs Frequency

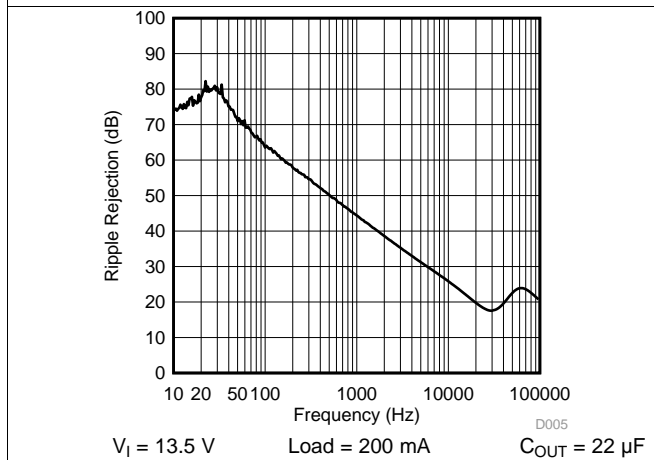

Figure 12. Power-Supply Ripple Rejection vs Frequency

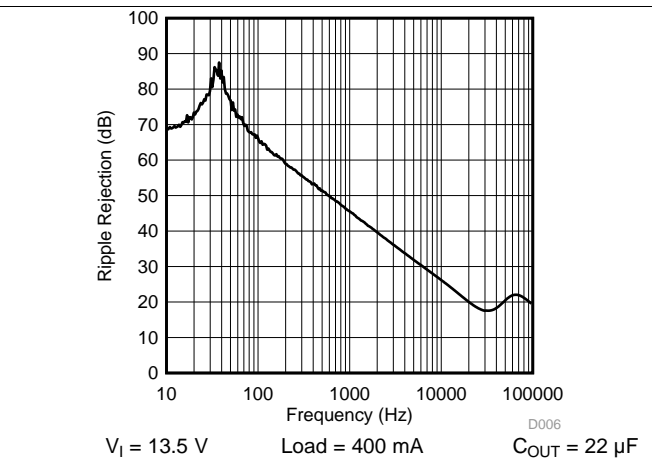

Figure 13. Power-Supply Ripple Rejection vs Frequency

Typical Characteristics (continued)

At $T_A = 25^\circ\text{C}$

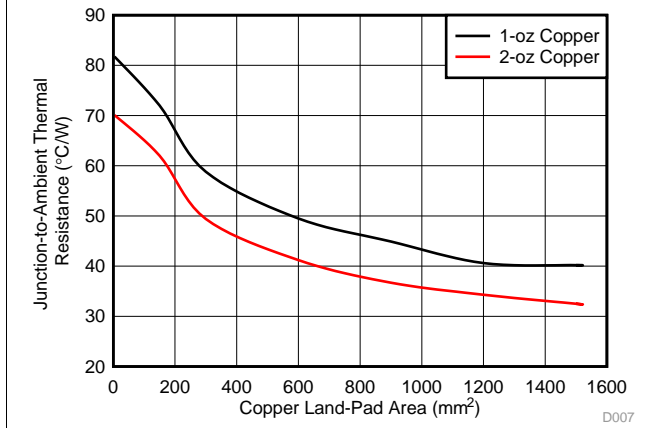

Figure 14. Thermal Resistance vs Copper Land Pad Area (JEDEC 51-3 Low-K Board)

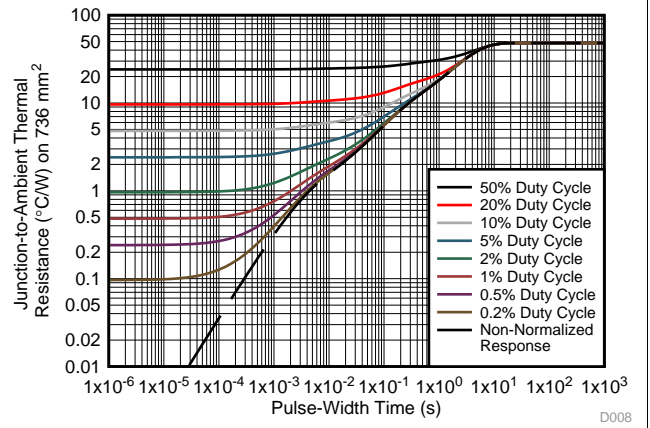

Figure 15. Thermal Resistance vs Pulse Width Time for Various Duty Cycles

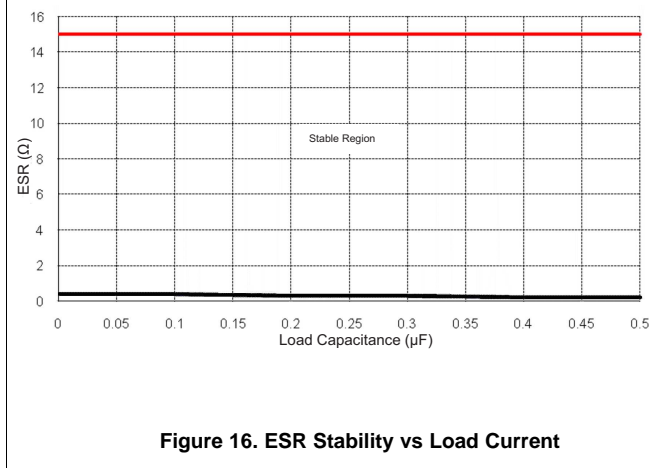

Figure 16. ESR Stability vs Load Current

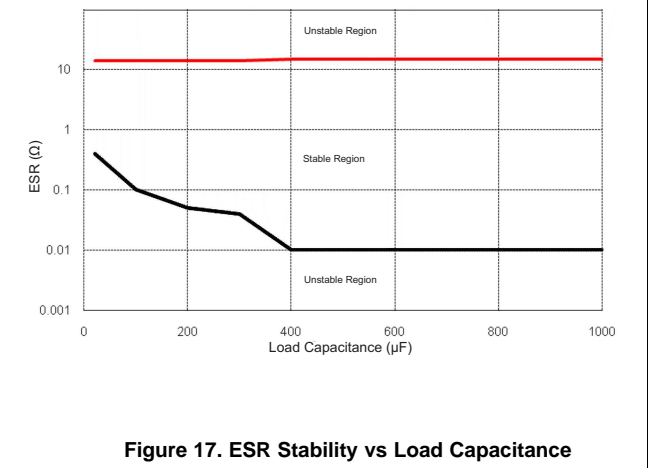

Figure 17. ESR Stability vs Load Capacitance

TLE4275-Q1

SLVS6471 – AUGUST 2006 – REVISED NOVEMBER 2014

www.ti.com

8 Parameter Measurement Information

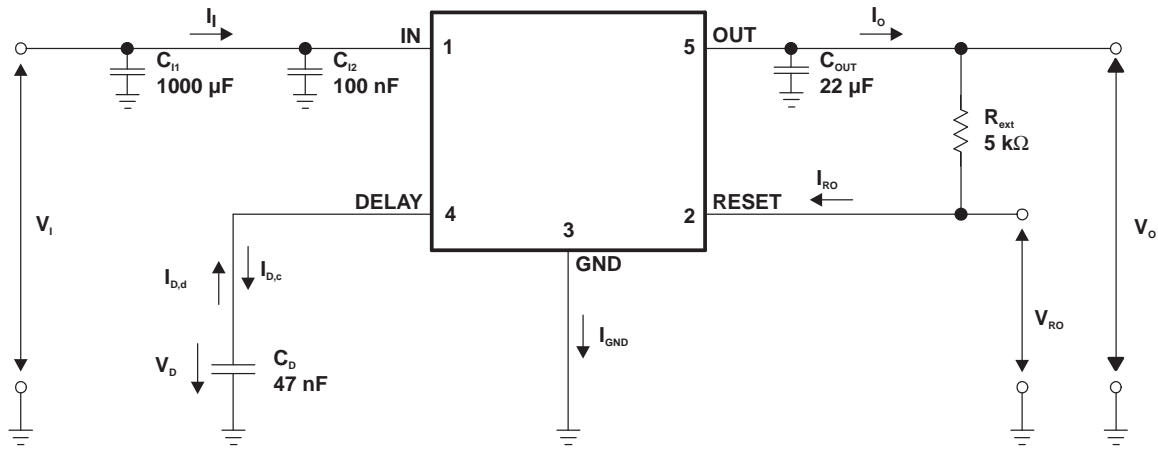

Figure 18. Test Circuit

9 Detailed Description

9.1 Overview

The TLE4275-Q1 device is a monolithic integrated low-dropout voltage regulator offered in a 5-pin TO package. The device regulates an input voltage up to 45 V to $V_{OUT} = 5$ V (typical). The device can drive loads up to 450 mA and is short circuit proof. At over temperature, the incorporated temperature protection turns off the TLE4275-Q1 device. The device generates a reset signal for an output voltage, $V_{OUT,rt}$ of 4.65 V (typical). By the use of an external delay capacitor, one can program the reset delay time.

9.2 Functional Block Diagram

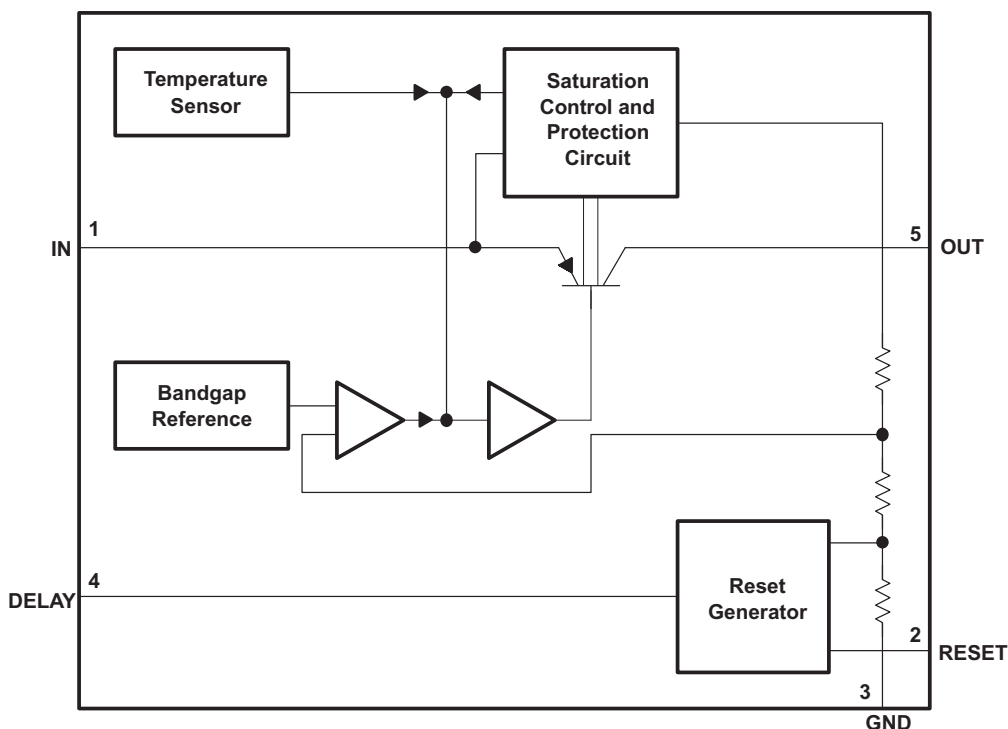

TLE4275-Q1

SLVS6471 – AUGUST 2006 – REVISED NOVEMBER 2014

www.ti.com

9.3 Feature Description

9.3.1 Regulated Output (OUT)

The OUT terminal is the regulated 5-V output. The output has current limitation. During initial power up, the regulator has a soft start incorporated to control the initial current through the pass element. In the event that the regulator drops out of regulation, the output tracks the input minus a drop based on the load current.

9.3.2 Power-On-Reset (RESET)

The power-on-reset is an output with an external pull up resistor to the regulated supply. The reset output remains low until the regulated V_O exceeds approximately 4.65 V and the power-on-reset delay has expired.

9.3.3 Reset Delay Timer (DELAY)

An external capacitor on this terminal sets the timer delay before the reset terminal is asserted high. The constant output current charges an external capacitor until the voltage exceeds a threshold to trip an internal comparator. The reset pulse delay time t_d , is defined with the charge time of an external capacitor DELAY.

$$t_d = \frac{C_{\text{delay}} \times V_{\text{DU}}}{I_{\text{D,c}}} \quad (1)$$

9.4 Device Functional Modes

9.4.1 Low-Voltage Tracking

At low input voltages, the regulator drops out of regulation and the output voltage tracks input minus a voltage based on the load current (I_O) and switch resistance ($R_{\text{(SW)}}$). This allows for a smaller input capacitor and can possibly eliminate the need of using a boost convertor during cold-crank conditions.

10 Application and Implementation

NOTE

Information in the following applications sections is not part of the TI component specification, and TI does not warrant its accuracy or completeness. TI's customers are responsible for determining suitability of components for their purposes. Customers should validate and test their design implementation to confirm system functionality.

10.1 Application Information

Figure 19 shows typical application circuits for the TLE4275-Q1. Based on the end-application, different values of external components can be used. An application can require a larger output capacitor during fast load steps in order to prevent a reset from occurring. TI recommends a low-ESR ceramic capacitor with a dielectric of type X5R or X7R for better load transient response.

10.2 Typical Application

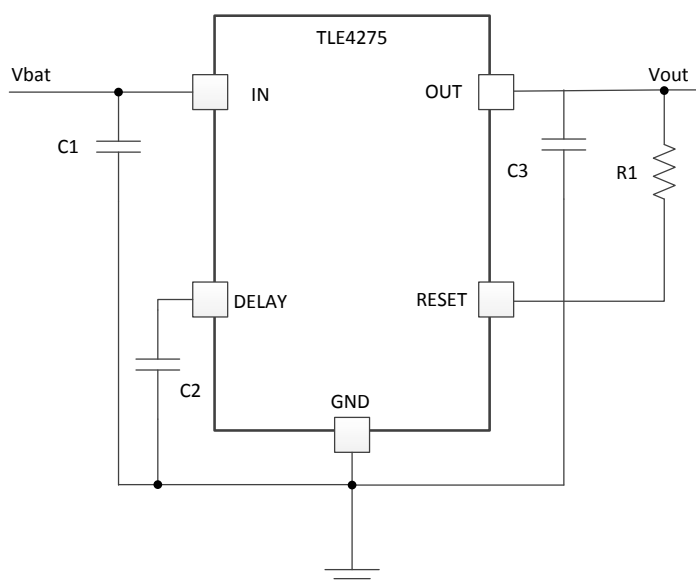

Figure 19. Typical Application Diagram

10.2.1 Design Requirements

For this design example, use the parameters listed in Table 1.

Table 1. Design Parameters

| DESIGN PARAMETER | EXAMPLE VALUE |
|----------------------------|-----------------------------|
| Input voltage range | 4 to 40 V |
| Output voltage | 5 V |
| Output current rating | 400 mA |
| Output capacitor range | 10 to 500 μ F |
| Output capacitor ESR range | 1 m Ω to 20 Ω |
| DELAY capacitor range | 100 pF to 500 nF |

TLE4275-Q1

SLVS6471 – AUGUST 2006 – REVISED NOVEMBER 2014

www.ti.com

10.2.2 Detailed Design Procedure

To begin the design process, determine the following:

- Input voltage range
- Output voltage
- Output current rating
- Output capacitor
- Power-up reset delay time

10.2.2.1 Power-Up Reset Capacitance

To calculate the power-up reset capacitance, use Equation 2.

$$t_d = \frac{C_{\text{delay}} \times V_{\text{DU}}}{I_{\text{D,c}}}$$

$$C_{\text{delay}} t_d = \frac{t_d \times I_{\text{D,c}}}{V_{\text{DU}}} = \frac{t_d \times 5.5 \times 10^{-6}}{1.8} \quad (2)$$

10.2.2.2 Thermal Consideration

Calculate the power dissipated by the device according to Equation 3.

$$P_T = I_O \times (V_I - V_O) + V_I \times I_Q$$

where

- P_T = Total power dissipation of the device.
- I_O = output current
- V_I = input voltage
- V_O = output voltage

After determining the power dissipated by the device, calculate the junction temperature from the ambient temperature and the device thermal impedance.

$$T_J = T_A + R_{\theta JA} \times P_T \quad (4)$$

10.2.3 Application Curves

Load = 200 mA, $C_{\text{in}} = 22 \mu\text{F}$, $C_{\text{out}} = 10 \mu\text{F}$

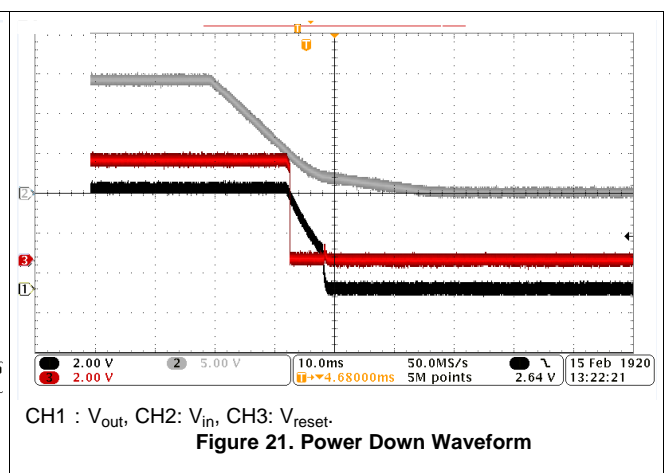
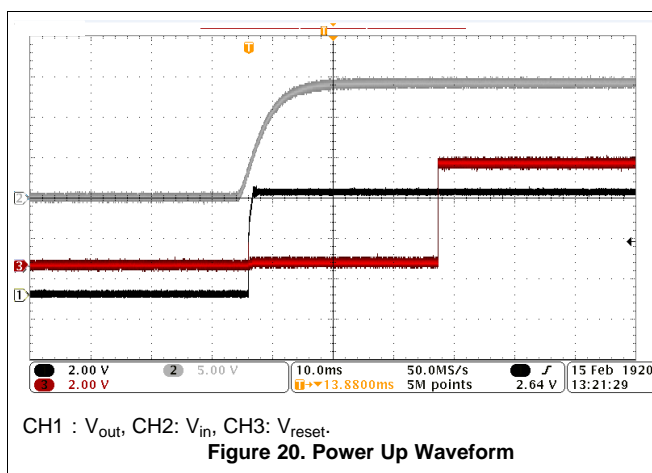

11 Power Supply Recommendations

The device is designed to operate from an input voltage supply range between 4 V and 40 V. This input supply must be well regulated. If the input supply is located more than a few inches from the TLE4275-Q1 device, an electrolytic capacitor with a value of 47 μF and a ceramic bypass capacitor are recommended to add at the input.

12 Layout

12.1 Layout Guidelines

- Do not place any of the capacitors on the opposite side of the PCB from where the regulator is installed. The use of vias and long traces is strongly discouraged because of the negative impact on system performance. Vias and long traces can also cause instability.
- Equivalent series inductance (ESL) and ESR must be minimized in order to maximize performance and ensure stability. Every capacitor must be placed as close to the device as possible and on the same side of the PCB as the regulator.

12.2 Layout Example

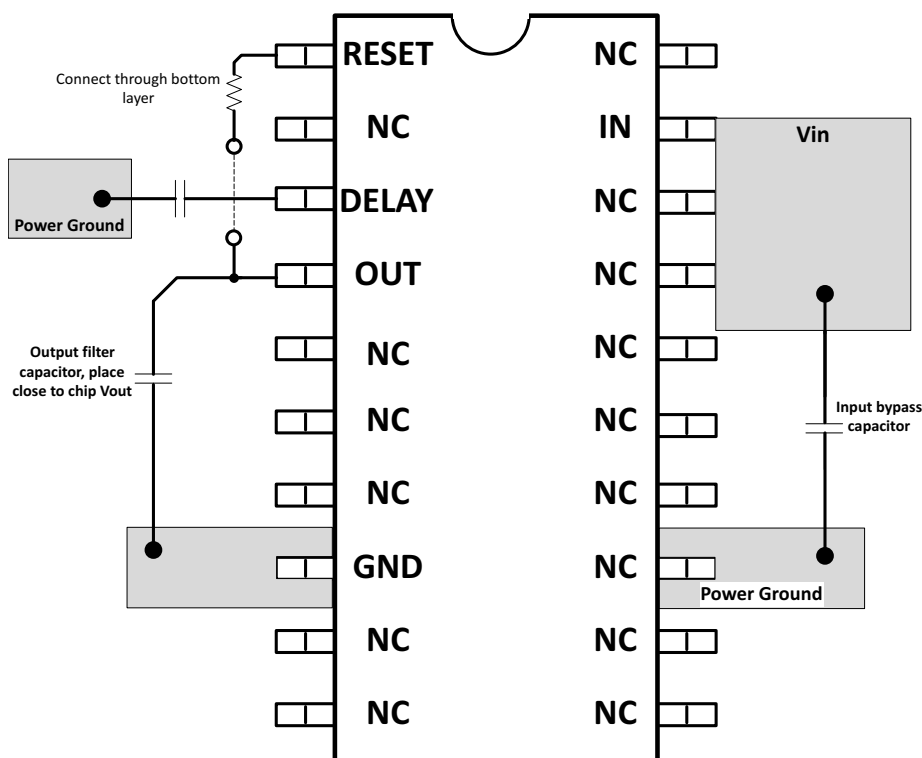

Figure 22. TLE4275-Q1 HTSSOP Layout Design Example

TLE4275-Q1

SLVS6471 – AUGUST 2006 – REVISED NOVEMBER 2014

www.ti.com

13 Device and Documentation Support

13.1 Documentation Support

13.1.1 Related Documentation

For related documentation see the following:

TLE4275-Q1 Low Temperature Stability, [SLVA501](#)

13.2 Trademarks

All trademarks are the property of their respective owners.

13.3 Electrostatic Discharge Caution



These devices have limited built-in ESD protection. The leads should be shorted together or the device placed in conductive foam during storage or handling to prevent electrostatic damage to the MOS gates.

13.4 Glossary

[SLYZ022](#) — *TI Glossary*.

This glossary lists and explains terms, acronyms, and definitions.

14 Mechanical, Packaging, and Orderable Information

The following pages include mechanical, packaging, and orderable information. This information is the most current data available for the designated devices. This data is subject to change without notice and revision of this document. For browser-based versions of this data sheet, refer to the left-hand navigation.



PACKAGING INFORMATION

| Orderable Device | Status (1) | Package Type | Package Drawing | Pins | Package Qty | Eco Plan (2) | Lead/Ball Finish (6) | MSL Peak Temp (3) | Op Temp (°C) | Device Marking (4/5) | Samples |
|------------------|------------|--------------|-----------------|------|-------------|-------------------------|----------------------|---------------------|--------------|----------------------|-------------------------|
| TLE4275QKTTTRQ1 | ACTIVE | DDPAK/TO-263 | KTT | 5 | 500 | Green (RoHS & no Sb/Br) | CU SN | Level-3-245C-168 HR | -40 to 125 | TLE4275Q | Samples |
| TLE4275QKVURQ1 | ACTIVE | TO-252 | KVU | 5 | 2500 | Green (RoHS & no Sb/Br) | CU SN | Level-3-260C-168 HR | -40 to 125 | TLE4275Q | Samples |
| TLE4275QPWPRQ1 | ACTIVE | HTSSOP | PWP | 20 | 2000 | Green (RoHS & no Sb/Br) | CU NIPDAU | Level-3-260C-168 HR | -40 to 125 | TLE4275Q | Samples |

(1) The marketing status values are defined as follows:

ACTIVE: Product device recommended for new designs.

LIFEBUY: TI has announced that the device will be discontinued, and a lifetime-buy period is in effect.

NRND: Not recommended for new designs. Device is in production to support existing customers, but TI does not recommend using this part in a new design.

PREVIEW: Device has been announced but is not in production. Samples may or may not be available.

OBSOLETE: TI has discontinued the production of the device.

(2) Eco Plan - The planned eco-friendly classification: Pb-Free (RoHS), Pb-Free (RoHS Exempt), or Green (RoHS & no Sb/Br) - please check <http://www.ti.com/productcontent> for the latest availability information and additional product content details.

TBD: The Pb-Free/Green conversion plan has not been defined.

Pb-Free (RoHS): TI's terms "Lead-Free" or "Pb-Free" mean semiconductor products that are compatible with the current RoHS requirements for all 6 substances, including the requirement that lead not exceed 0.1% by weight in homogeneous materials. Where designed to be soldered at high temperatures, TI Pb-Free products are suitable for use in specified lead-free processes.

Pb-Free (RoHS Exempt): This component has a RoHS exemption for either 1) lead-based flip-chip solder bumps used between the die and package, or 2) lead-based die adhesive used between the die and leadframe. The component is otherwise considered Pb-Free (RoHS compatible) as defined above.

Green (RoHS & no Sb/Br): TI defines "Green" to mean Pb-Free (RoHS compatible), and free of Bromine (Br) and Antimony (Sb) based flame retardants (Br or Sb do not exceed 0.1% by weight in homogeneous material)

(3) MSL, Peak Temp. - The Moisture Sensitivity Level rating according to the JEDEC industry standard classifications, and peak solder temperature.

(4) There may be additional marking, which relates to the logo, the lot trace code information, or the environmental category on the device.

(5) Multiple Device Markings will be inside parentheses. Only one Device Marking contained in parentheses and separated by a "-" will appear on a device. If a line is indented then it is a continuation of the previous line and the two combined represent the entire Device Marking for that device.

(6) Lead/Ball Finish - Orderable Devices may have multiple material finish options. Finish options are separated by a vertical ruled line. Lead/Ball Finish values may wrap to two lines if the finish value exceeds the maximum column width.

Important Information and Disclaimer: The information provided on this page represents TI's knowledge and belief as of the date that it is provided. TI bases its knowledge and belief on information provided by third parties, and makes no representation or warranty as to the accuracy of such information. Efforts are underway to better integrate information from third parties. TI has taken and



Distributor of Texas Instruments: Excellent Integrated System Limited

Datasheet of TLE4275QKTTRQ1 - IC REG LDO 5V 0.45A DDPAK

Contact us: sales@integrated-circuit.com Website: www.integrated-circuit.com

PACKAGE OPTION ADDENDUM

www.ti.com

4-Oct-2014

continues to take reasonable steps to provide representative and accurate information but may not have conducted destructive testing or chemical analysis on incoming materials and chemicals. TI and TI suppliers consider certain information to be proprietary, and thus CAS numbers and other limited information may not be available for release.

In no event shall TI's liability arising out of such information exceed the total purchase price of the TI part(s) at issue in this document sold by TI to Customer on an annual basis.

TAPE AND REEL INFORMATION

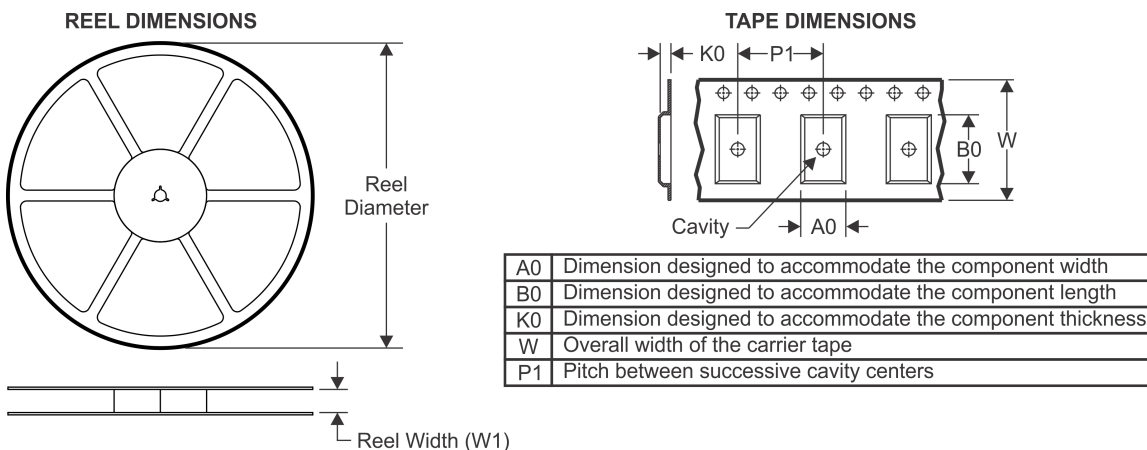

QUADRANT ASSIGNMENTS FOR PIN 1 ORIENTATION IN TAPE

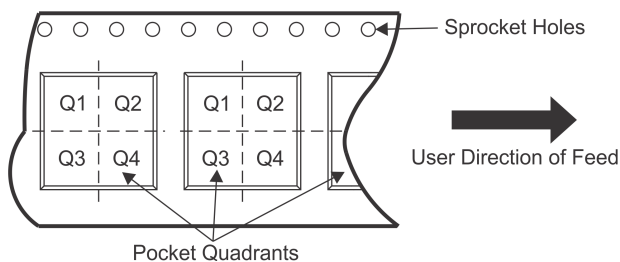

*All dimensions are nominal

| Device | Package Type | Package Drawing | Pins | SPQ | Reel Diameter (mm) | Reel Width W1 (mm) | A0 (mm) | B0 (mm) | K0 (mm) | P1 (mm) | W (mm) | Pin1 Quadrant |
|----------------|--------------|-----------------|------|------|--------------------|--------------------|---------|---------|---------|---------|--------|---------------|
| TLE4275QKTTRQ1 | DDPAK/TO-263 | KTT | 5 | 500 | 330.0 | 24.4 | 10.6 | 15.8 | 4.9 | 16.0 | 24.0 | Q2 |
| TLE4275QKVURQ1 | TO-252 | KVU | 5 | 2500 | 330.0 | 16.4 | 6.9 | 10.5 | 2.7 | 8.0 | 16.0 | Q2 |
| TLE4275QPWPRQ1 | HTSSOP | PWP | 20 | 2000 | 330.0 | 16.4 | 6.95 | 7.1 | 1.6 | 8.0 | 16.0 | Q1 |

TAPE AND REEL BOX DIMENSIONS



*All dimensions are nominal

| Device | Package Type | Package Drawing | Pins | SPQ | Length (mm) | Width (mm) | Height (mm) |
|----------------|--------------|-----------------|------|------|-------------|------------|-------------|
| TLE4275QKTTRQ1 | DDPAK/TO-263 | KTT | 5 | 500 | 340.0 | 340.0 | 38.0 |
| TLE4275QKVURQ1 | TO-252 | KVU | 5 | 2500 | 340.0 | 340.0 | 38.0 |
| TLE4275QPWPRQ1 | HTSSOP | PWP | 20 | 2000 | 367.0 | 367.0 | 38.0 |

MECHANICAL DATA

PWP (R-PDSO-G20)

PowerPAD™ PLASTIC SMALL OUTLINE

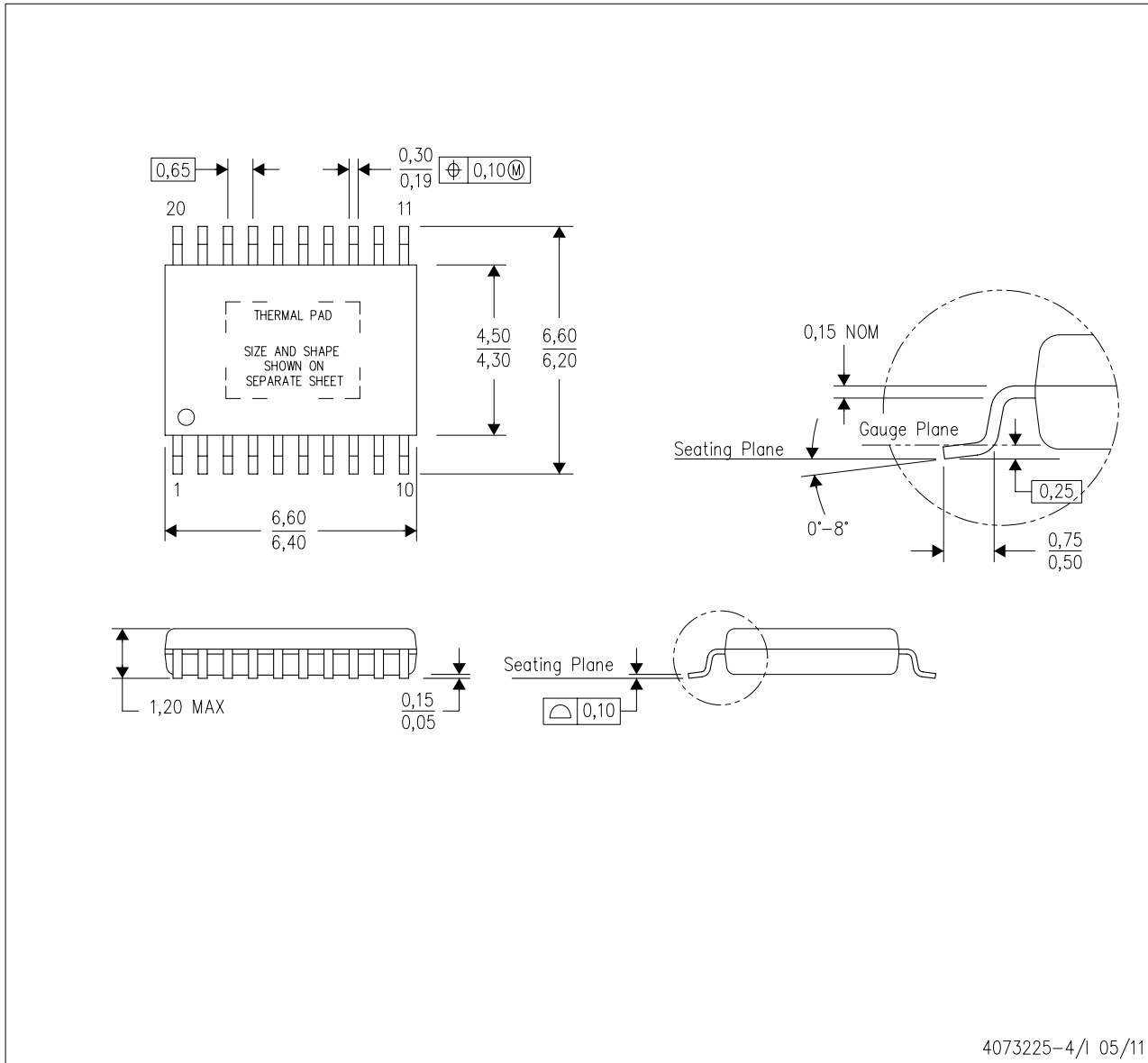

- NOTES:
- All linear dimensions are in millimeters.
 - This drawing is subject to change without notice.
 - Body dimensions do not include mold flash or protrusions. Mold flash and protrusion shall not exceed 0.15 per side.
 - This package is designed to be soldered to a thermal pad on the board. Refer to Technical Brief, PowerPad Thermally Enhanced Package, Texas Instruments Literature No. SLMA002 for information regarding recommended board layout. This document is available at www.ti.com <<http://www.ti.com>>.
 - See the additional figure in the Product Data Sheet for details regarding the exposed thermal pad features and dimensions.
 - Falls within JEDEC MO-153

PowerPAD is a trademark of Texas Instruments.

THERMAL PAD MECHANICAL DATA

PWP (R-PDSO-G20) PowerPAD™ SMALL PLASTIC OUTLINE

THERMAL INFORMATION

This PowerPAD™ package incorporates an exposed thermal pad that is designed to be attached to a printed circuit board (PCB). The thermal pad must be soldered directly to the PCB. After soldering, the PCB can be used as a heatsink. In addition, through the use of thermal vias, the thermal pad can be attached directly to the appropriate copper plane shown in the electrical schematic for the device, or alternatively, can be attached to a special heatsink structure designed into the PCB. This design optimizes the heat transfer from the integrated circuit (IC).

For additional information on the PowerPAD package and how to take advantage of its heat dissipating abilities, refer to Technical Brief, PowerPAD Thermally Enhanced Package, Texas Instruments Literature No. SLMA002 and Application Brief, PowerPAD Made Easy, Texas Instruments Literature No. SLMA004. Both documents are available at www.ti.com.

The exposed thermal pad dimensions for this package are shown in the following illustration.

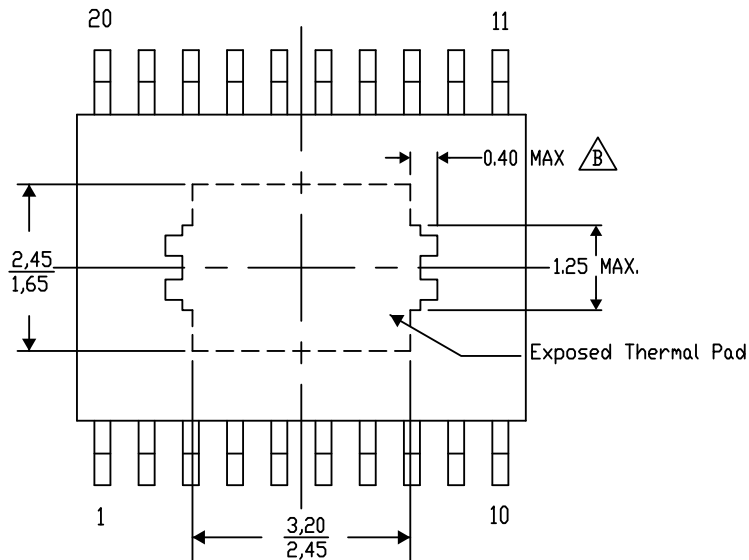

Top View

Exposed Thermal Pad Dimensions

4206332-18/AO 01/16

NOTE: A. All linear dimensions are in millimeters

 Exposed tie strap features may not be present.

PowerPAD is a trademark of Texas Instruments

LAND PATTERN DATA

PWP (R-PDSO-G20)

PowerPAD™ PLASTIC SMALL OUTLINE

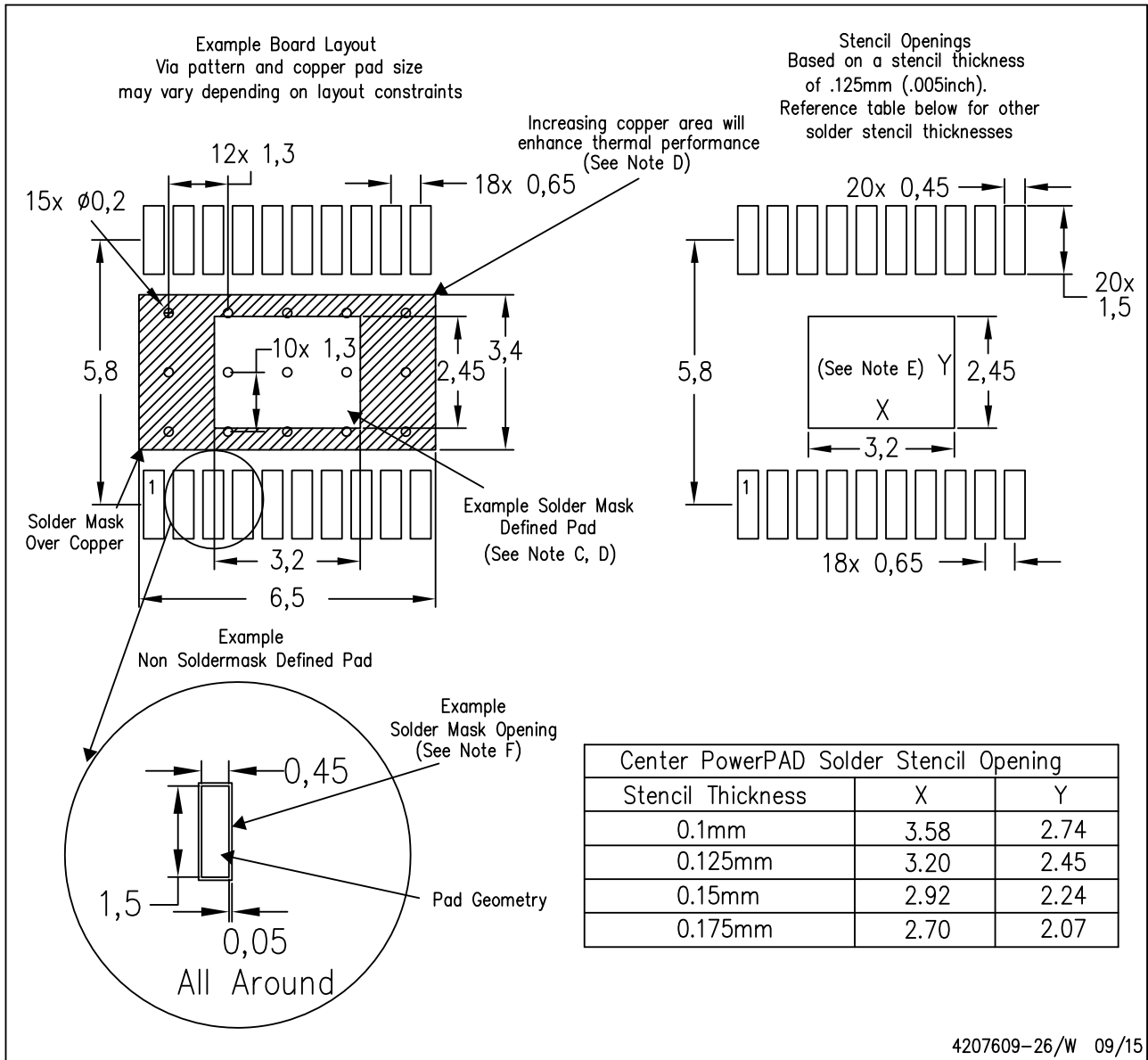

4207609-26/W 09/15

- NOTES:
- All linear dimensions are in millimeters.
 - This drawing is subject to change without notice.
 - Customers should place a note on the circuit board fabrication drawing not to alter the center solder mask defined pad.
 - This package is designed to be soldered to a thermal pad on the board. Refer to Technical Brief, PowerPad Thermally Enhanced Package, Texas Instruments Literature No. SLMA002, SLMA004, and also the Product Data Sheets for specific thermal information, via requirements, and recommended board layout. These documents are available at www.ti.com <<http://www.ti.com>>. Publication IPC-7351 is recommended for alternate designs.
 - Laser cutting apertures with trapezoidal walls and also rounding corners will offer better paste release. Customers should contact their board assembly site for stencil design recommendations. Example stencil design based on a 50% volumetric metal load solder paste. Refer to IPC-7525 for other stencil recommendations.
 - Customers should contact their board fabrication site for solder mask tolerances between and around signal pads.

MECHANICAL DATA

KTT (R-PSFM-G5)

PLASTIC FLANGE-MOUNT PACKAGE

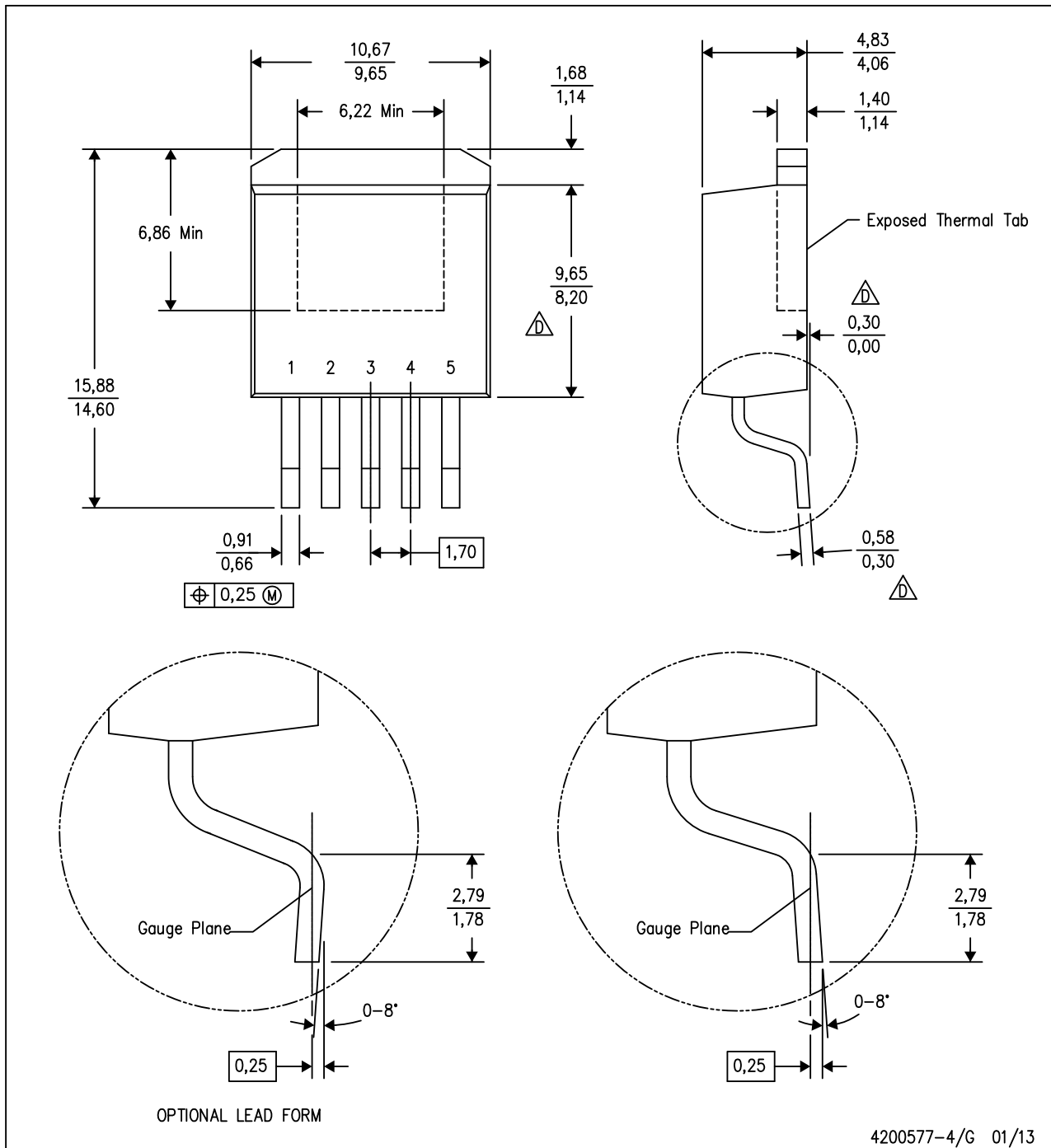

- NOTES:
- A. All linear dimensions are in millimeters.
 - B. This drawing is subject to change without notice.
 - C. Body dimensions do not include mold flash or protrusion. Mold flash or protrusion not to exceed 0.005 (0,13) per side.
- ⚠ Falls within JEDEC TO-263 variation BA, except minimum lead thickness, maximum seating height, and minimum body length.

LAND PATTERN DATA

KTT (R-PSFM-G5)

PLASTIC FLANGE-MOUNT PACKAGE

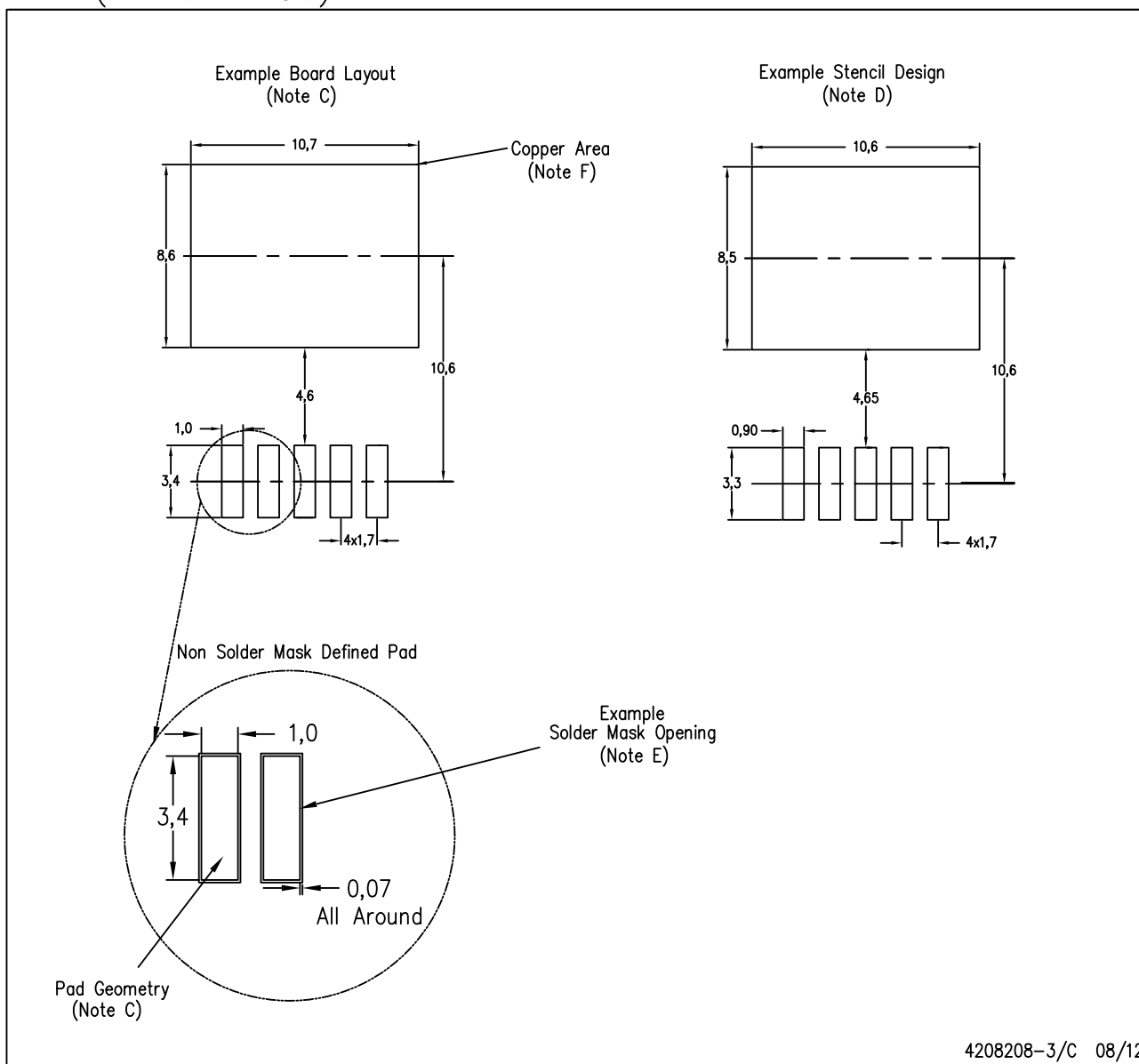

- NOTES:
- A. All linear dimensions are in millimeters.
 - B. This drawing is subject to change without notice.
 - C. Publication IPC-SM-782 is recommended for alternate designs.
 - D. Laser cutting apertures with trapezoidal walls and also rounding corners will offer better paste release. Customers should contact their board assembly site for stencil design recommendations. Refer to IPC-7525.
 - E. Customers should contact their board fabrication site for solder mask tolerances between and around signal pads.
 - F. This package is designed to be soldered to a thermal pad on the board. Refer to the Product Datasheet for specific thermal information, via requirements, and recommended thermal pad size. For thermal pad sizes larger than shown a solder mask defined pad is recommended in order to maintain the solderable pad geometry while increasing copper area.

MECHANICAL DATA

KVU (R-PSFM-G5)

PLASTIC FLANGE-MOUNT PACKAGE

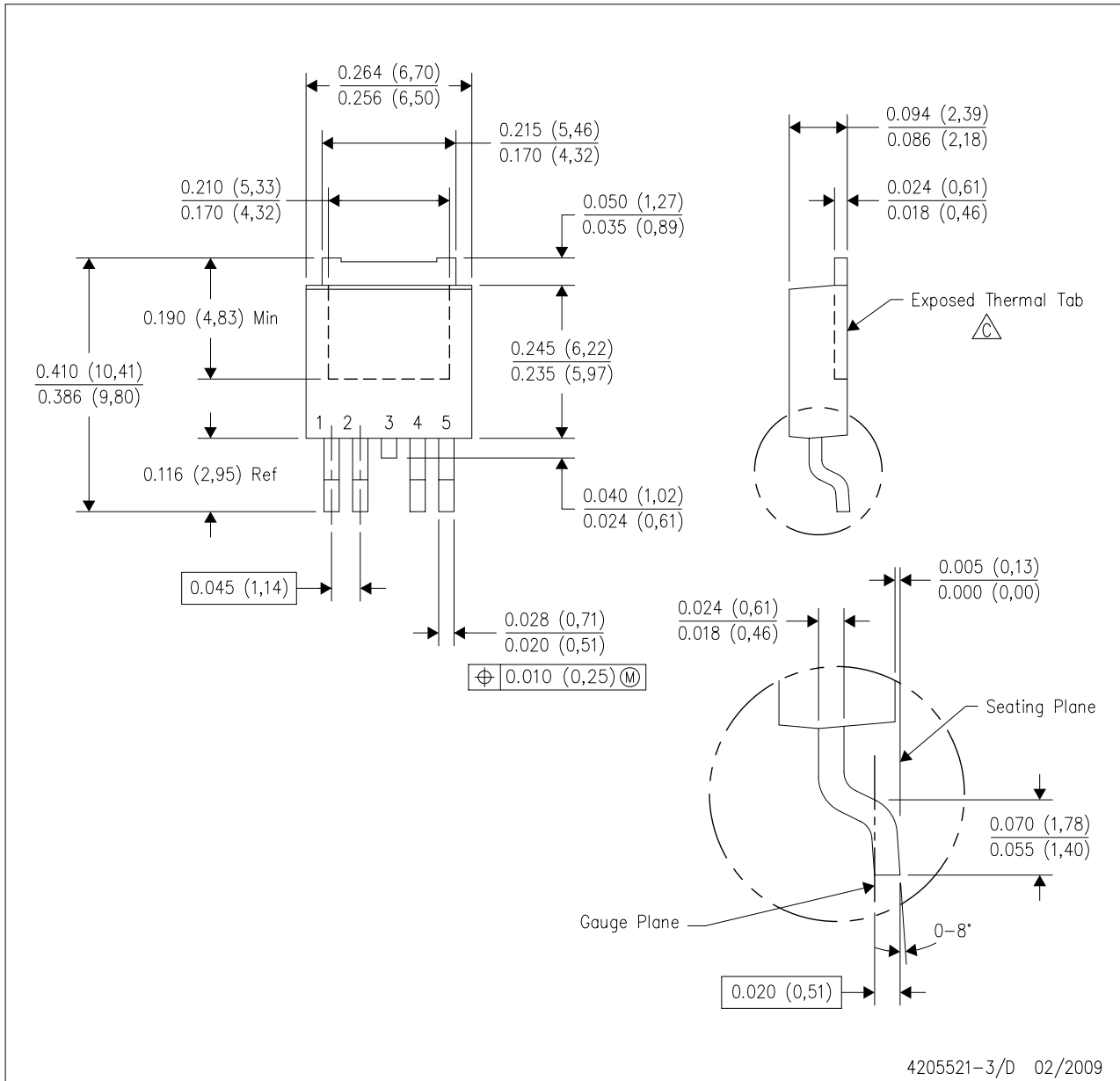

- NOTES:
- A. All linear dimensions are in inches (millimeters).
 - B. This drawing is subject to change without notice.
 - The center lead is in electrical contact with the exposed thermal tab.
 - D. Body Dimensions do not include mold flash or protrusions. Mold flash and protrusion shall not exceed 0.006 (0,15) per side.
 - E. Falls within JEDEC TO-252 variation AD.

LAND PATTERN DATA

KVU (R-PSFM-G5)

PLASTIC FLANGE MOUNT PACKAGE

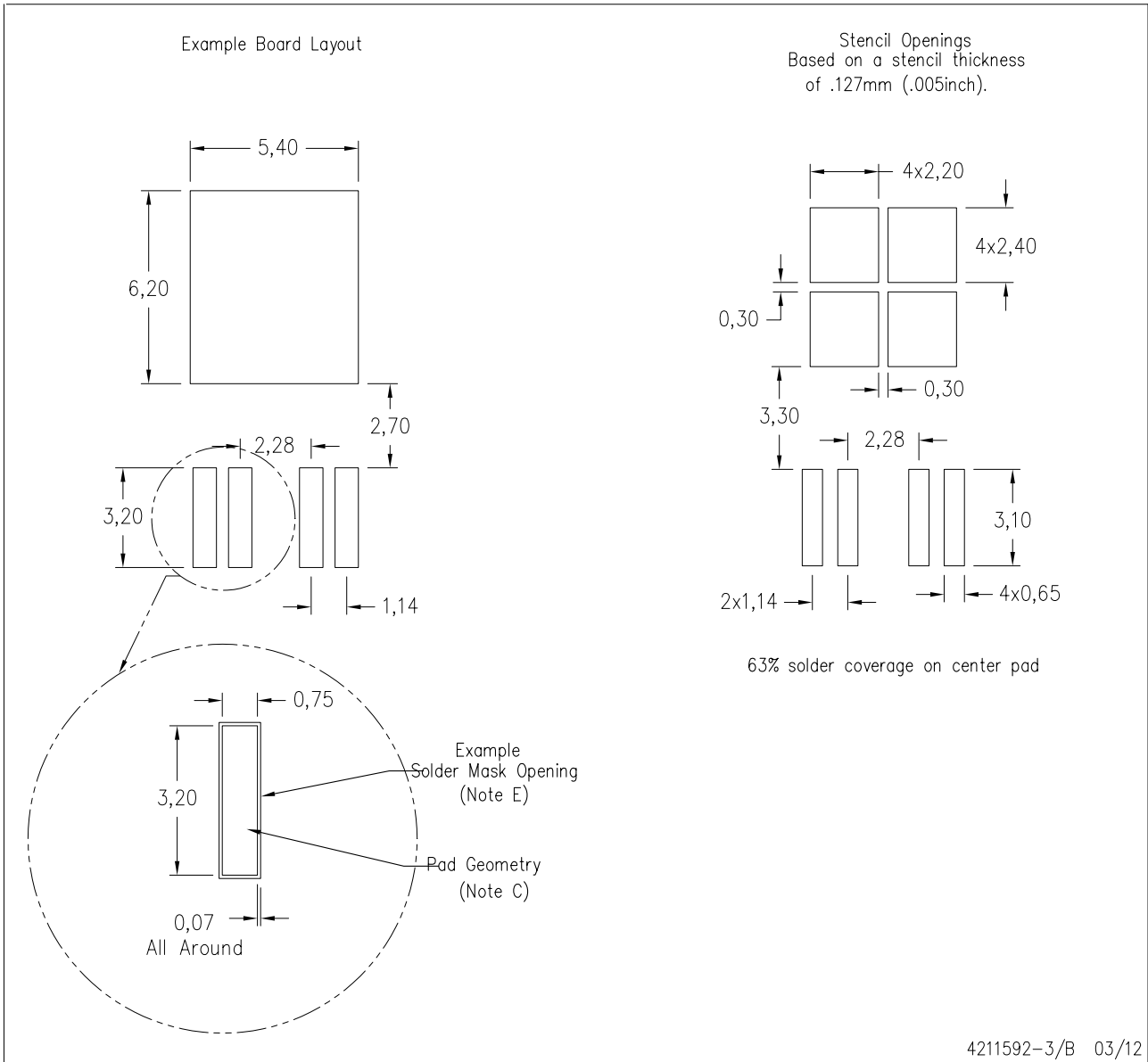

- NOTES:
- A. All linear dimensions are in millimeters.
 - B. This drawing is subject to change without notice.
 - C. Publication IPC-SM-782 is an alternate information source for PCB land pattern designs.
 - D. Laser cutting apertures with trapezoidal walls and also rounding corners will offer better paste release. Customers should contact their board assembly site for stencil design recommendations. Refer to IPC-7525 for other stencil recommendations.
 - E. Customers should contact their board fabrication site for recommended solder mask tolerances and via tenting recommendations for vias placed in thermal pad.

IMPORTANT NOTICE

Texas Instruments Incorporated and its subsidiaries (TI) reserve the right to make corrections, enhancements, improvements and other changes to its semiconductor products and services per JESD46, latest issue, and to discontinue any product or service per JESD48, latest issue. Buyers should obtain the latest relevant information before placing orders and should verify that such information is current and complete. All semiconductor products (also referred to herein as “components”) are sold subject to TI’s terms and conditions of sale supplied at the time of order acknowledgment.

TI warrants performance of its components to the specifications applicable at the time of sale, in accordance with the warranty in TI’s terms and conditions of sale of semiconductor products. Testing and other quality control techniques are used to the extent TI deems necessary to support this warranty. Except where mandated by applicable law, testing of all parameters of each component is not necessarily performed.

TI assumes no liability for applications assistance or the design of Buyers’ products. Buyers are responsible for their products and applications using TI components. To minimize the risks associated with Buyers’ products and applications, Buyers should provide adequate design and operating safeguards.

TI does not warrant or represent that any license, either express or implied, is granted under any patent right, copyright, mask work right, or other intellectual property right relating to any combination, machine, or process in which TI components or services are used. Information published by TI regarding third-party products or services does not constitute a license to use such products or services or a warranty or endorsement thereof. Use of such information may require a license from a third party under the patents or other intellectual property of the third party, or a license from TI under the patents or other intellectual property of TI.

Reproduction of significant portions of TI information in TI data books or data sheets is permissible only if reproduction is without alteration and is accompanied by all associated warranties, conditions, limitations, and notices. TI is not responsible or liable for such altered documentation. Information of third parties may be subject to additional restrictions.

Resale of TI components or services with statements different from or beyond the parameters stated by TI for that component or service voids all express and any implied warranties for the associated TI component or service and is an unfair and deceptive business practice. TI is not responsible or liable for any such statements.

Buyer acknowledges and agrees that it is solely responsible for compliance with all legal, regulatory and safety-related requirements concerning its products, and any use of TI components in its applications, notwithstanding any applications-related information or support that may be provided by TI. Buyer represents and agrees that it has all the necessary expertise to create and implement safeguards which anticipate dangerous consequences of failures, monitor failures and their consequences, lessen the likelihood of failures that might cause harm and take appropriate remedial actions. Buyer will fully indemnify TI and its representatives against any damages arising out of the use of any TI components in safety-critical applications.

In some cases, TI components may be promoted specifically to facilitate safety-related applications. With such components, TI’s goal is to help enable customers to design and create their own end-product solutions that meet applicable functional safety standards and requirements. Nonetheless, such components are subject to these terms.

No TI components are authorized for use in FDA Class III (or similar life-critical medical equipment) unless authorized officers of the parties have executed a special agreement specifically governing such use.

Only those TI components which TI has specifically designated as military grade or “enhanced plastic” are designed and intended for use in military/aerospace applications or environments. Buyer acknowledges and agrees that any military or aerospace use of TI components which have **not** been so designated is solely at the Buyer’s risk, and that Buyer is solely responsible for compliance with all legal and regulatory requirements in connection with such use.

TI has specifically designated certain components as meeting ISO/TS16949 requirements, mainly for automotive use. In any case of use of non-designated products, TI will not be responsible for any failure to meet ISO/TS16949.

Products

| | |
|------------------------------|--|
| Audio | www.ti.com/audio |
| Amplifiers | amplifier.ti.com |
| Data Converters | dataconverter.ti.com |
| DLP® Products | www.dlp.com |
| DSP | dsp.ti.com |
| Clocks and Timers | www.ti.com/clocks |
| Interface | interface.ti.com |
| Logic | logic.ti.com |
| Power Mgmt | power.ti.com |
| Microcontrollers | microcontroller.ti.com |
| RFID | www.ti-rfid.com |
| OMAP Applications Processors | www.ti.com/omap |
| Wireless Connectivity | www.ti.com/wirelessconnectivity |

Applications

| | |
|-------------------------------|--|
| Automotive and Transportation | www.ti.com/automotive |
| Communications and Telecom | www.ti.com/communications |
| Computers and Peripherals | www.ti.com/computers |
| Consumer Electronics | www.ti.com/consumer-apps |
| Energy and Lighting | www.ti.com/energy |
| Industrial | www.ti.com/industrial |
| Medical | www.ti.com/medical |
| Security | www.ti.com/security |
| Space, Avionics and Defense | www.ti.com/space-avionics-defense |
| Video and Imaging | www.ti.com/video |

TI E2E Community

e2e.ti.com