



Distributor of Texas Instruments: Excellent Integrated System Limited

Datasheet of TLC5928DBQR - IC LED Driver Linear 35mA 24-SSOP/QSOP

Contact us: sales@integrated-circuit.com Website: www.integrated-circuit.com

Excellent Integrated System Limited

Stocking Distributor

Click to view price, real time Inventory, Delivery & Lifecycle Information:

[Texas Instruments](#)
[TLC5928DBQR](#)

For any questions, you can email us directly:

sales@integrated-circuit.com

16-Channel, Constant-Current LED Driver with LED Open Detection

Check for Samples: [TLC5928](#)

FEATURES

- 16 Channels, Constant-Current Sink Output with On/Off Control
- 35-mA Capability (Constant-Current Sink)
- 10-ns High-Speed Constant-Current Switching Transient Time
- Low On-Time Error
- LED Power-Supply Voltage up to 17 V
- $V_{CC} = 3.0\text{ V to }5.5\text{ V}$
- Constant-Current Accuracy:
 - Channel-to-Channel = $\pm 1\%$
 - Device-to-Device = $\pm 1\%$
- CMOS Logic Level I/O
- 35-MHz Data Transfer Rate
- 20-ns BLANK Pulse Width
- Readable Error Information:
 - LED Open Detection (LOD)
 - Pre-Thermal Warning (PTW)
- Operating Temperature: $-40^{\circ}\text{C to }+85^{\circ}\text{C}$

APPLICATIONS

- LED Video Displays
- Message Boards
- Illumination

DESCRIPTION

The TLC5928 is a 16-channel, constant-current sink LED driver. Each channel can be turned on/off by writing serial data to an internal register. The constant-current value of all 16 channels is set by a single external resistor.

The TLC5928 has two error detection circuits: one for LED open detection (LOD) and one for a pre-thermal warning (PTW). LOD detects a broken or disconnected LED and LEDs shorted to GND while the constant-current output is on. PTW indicates a high temperature condition.

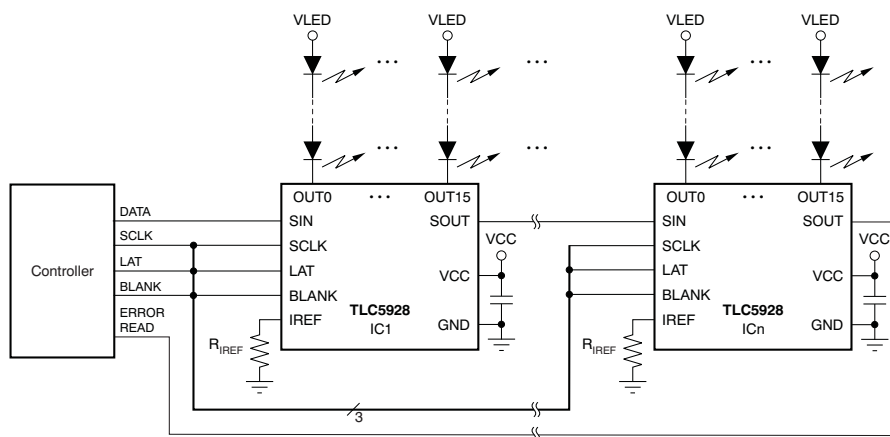

Typical Application Circuit (Multiple Daisy-Chained TLC5928s)



Please be aware that an important notice concerning availability, standard warranty, and use in critical applications of Texas Instruments semiconductor products and disclaimers thereto appears at the end of this data sheet.

PowerPAD is a trademark of Texas Instruments, Inc.
 All other trademarks are the property of their respective owners.



This integrated circuit can be damaged by ESD. Texas Instruments recommends that all integrated circuits be handled with appropriate precautions. Failure to observe proper handling and installation procedures can cause damage.

ESD damage can range from subtle performance degradation to complete device failure. Precision integrated circuits may be more susceptible to damage because very small parametric changes could cause the device not to meet its published specifications.

PACKAGE/ORDERING INFORMATION⁽¹⁾

PRODUCT	PACKAGE-LEAD	ORDERING NUMBER	TRANSPORT MEDIA, QUANTITY
TLC5928	SSOP-24/QSOP-24	TLC5928DBQR	Tape and Reel, 2500
		TLC5928DBQ	Tube, 50
TLC5928	TSSOP-24	TLC5928PWR	Tape and Reel, 2000
		TLC5928PW	Tube, 60
TLC5928	HTSSOP-24 PowerPAD™	TLC5928PWPR	Tape and Reel, 2000
		TLC5928PWP	Tube, 60
TLC5928	QFN-24	TLC5928RGER	Tape and Reel, 3000
		TLC5928RGE	Tape and Reel, 250

- (1) For the most current package and ordering information, see the Package Option Addendum at the end of this document, or visit the device product folder at www.ti.com.

ABSOLUTE MAXIMUM RATINGS⁽¹⁾⁽²⁾

Over operating free-air temperature range, unless otherwise noted.

PARAMETER		TLC5928	UNIT
V _{CC}	Supply voltage: V _{CC}	-0.3 to +6.0	V
I _{OUT}	Output current (dc) OUT0 to OUT15	40	mA
V _{IN}	Input voltage range SIN, SCLK, LAT, BLANK, IREF	-0.3 to V _{CC} + 0.3	V
V _{OUT}	Output voltage range SOUT	-0.3 to V _{CC} + 0.3	V
	OUT0 to OUT15	-0.3 to +18	V
T _{J(MAX)}	Operating junction temperature	+150	°C
T _{STG}	Storage temperature range	-55 to +150	°C
ESD rating	Human body model (HBM)	2	kV
	Charged device model (CDM)	500	V

- (1) Stresses above these ratings may cause permanent damage. Exposure to absolute maximum conditions for extended periods may degrade device reliability. These are stress ratings only, and functional operation of the device at these or any other conditions beyond those specified is not supported.
- (2) All voltage values are with respect to network ground terminal.

DISSIPATION RATINGS

PACKAGE	OPERATING FACTOR ABOVE T _A = +25°C	T _A < +25°C POWER RATING	T _A = +70°C POWER RATING	T _A = +85°C POWER RATING
SSOP-24/QSOP-24	14.3 mW/°C	1782 mW	1140 mW	927 mW
TSSOP-24	9.6 mW/°C	1194 mW	764 mW	621 mW
HTSSOP-24 ⁽¹⁾	28.9 mW/°C	3611 mW	2311 mW	1878 mW
QFN-24 ⁽²⁾	24.8 mW/°C	3106 mW	1988 mW	1615 mW

- (1) With PowerPAD soldered onto copper area on printed circuit board (PCB); 2 oz. copper. For more information, see [SLMA002](#) (available for download at www.ti.com).
- (2) The package thermal impedance is calculated in accordance with JESD51-5.

RECOMMENDED OPERATING CONDITIONS

At $T_A = -40^\circ\text{C}$ to $+85^\circ\text{C}$, unless otherwise noted.

PARAMETER	TEST CONDITIONS	TLC5928			UNIT
		MIN	NOM	MAX	
DC Characteristics: $V_{CC} = 3\text{ V to }5.5\text{ V}$					
V_{CC}	Supply voltage	3.0		5.5	V
V_O	Voltage applied to output		OUT0 to OUT15	17	V
V_{IH}	High-level input voltage	$0.7 \times V_{CC}$		V_{CC}	V
V_{IL}	Low-level input voltage	GND		$0.3 \times V_{CC}$	V
I_{OH}	High-level output current		SOUT	-1	mA
I_{OL}	Low-level output current		SOUT	1	mA
I_{OLC}	Constant output sink current		OUT0 to OUT15	35	mA
T_A	Operating free-air temperature range	-40		+85	$^\circ\text{C}$
T_J	Operating junction temperature range	-40		+125	$^\circ\text{C}$
AC Characteristics: $V_{CC} = 3\text{ V to }5.5\text{ V}$					
f_{CLK} (SCLK)	Data shift clock frequency		SCLK	35	MHz
T_{WH0}	Pulse duration		SCLK	10	ns
T_{WL0}			SCLK	10	ns
T_{WH1}			LAT	20	ns
T_{WH2}			BLANK	20	ns
T_{WL2}			BLANK	20	ns
T_{SU0}		Setup time		SIN-SCLK \uparrow	4
T_{SU1}			LAT \uparrow -SCLK \uparrow	100	ns
T_{H0}	Hold time		SIN-SCLK \uparrow	3	ns
T_{H1}			LAT \uparrow -SCLK \uparrow	10	ns

ELECTRICAL CHARACTERISTICS

At $V_{CC} = 3.0\text{ V}$ to 5.5 V and $T_A = -40^\circ\text{C}$ to $+85^\circ\text{C}$. Typical values at $V_{CC} = 3.3\text{ V}$ and $T_A = +25^\circ\text{C}$, unless otherwise noted.

PARAMETER		TEST CONDITIONS	TLC5928			UNIT
			MIN	TYP	MAX	
V_{OH}	High-level output voltage	$I_{OH} = -1\text{ mA}$ at SOUT	$V_{CC} - 0.4$		V_{CC}	V
V_{OL}	Low-level output voltage	$I_{OL} = 1\text{ mA}$ at SOUT	0		0.4	V
I_{IN}	Input current	$V_{IN} = V_{CC}$ or GND at SIN, SCLK, LAT, and BLANK	-1		1	μA
I_{CC1}	Supply current (V_{CC})	SIN/SCLK/LAT = low, BLANK = high, $V_{OUTn} = 1\text{ V}$, $R_{IREF} = 27\text{ k}\Omega$	1		2	mA
I_{CC2}		SIN/SCLK/LAT = low, BLANK = high, $V_{OUTn} = 1\text{ V}$, $R_{IREF} = 3\text{ k}\Omega$	4.5		8	mA
I_{CC3}		SIN/SCLK/LAT/BLANK = low, $V_{OUTn} = 1\text{ V}$, $R_{IREF} = 3\text{ k}\Omega$	7		18	mA
I_{CC4}		SIN/SCLK/LAT/BLANK = low, $V_{OUTn} = 1\text{ V}$, $R_{IREF} = 1.5\text{ k}\Omega$	16		40	mA
I_{OLC}	Constant output current	All $OUTn = \text{ON}$, $V_{OUTn} = V_{OUTfix} = 1\text{ V}$, $R_{IREF} = 1.5\text{ k}\Omega$ (see Figure 6), at $OUT0$ to $OUT15$	31	34	37	mA
I_{OLKG}	Output leakage current	All $OUTn$ for constant-current driver, all outputs off BLANK = high, $V_{OUTn} = V_{OUTfix} = 17\text{ V}$, $R_{IREF} = 1.5\text{ k}\Omega$ (see Figure 6), at $OUT0$ to $OUT15$			0.1	μA
ΔI_{OLC}	Constant-current error (channel-to-channel) ⁽¹⁾	All $OUTn = \text{ON}$, $V_{OUTn} = V_{OUTfix} = 1\text{ V}$, $R_{IREF} = 1.5\text{ k}\Omega$ at $OUT0$ to $OUT15$			± 1	± 3 %
ΔI_{OLC1}	Constant-current error (device-to-device) ⁽²⁾	All $OUTn = \text{ON}$, $V_{OUTn} = V_{OUTfix} = 1\text{ V}$, $R_{IREF} = 1.5\text{ k}\Omega$ at $OUT0$ to $OUT15$			± 1	± 6 %
ΔI_{OLC2}	Line regulation ⁽³⁾	All $OUTn = \text{ON}$, $V_{OUTn} = V_{OUTfix} = 1\text{ V}$, $R_{IREF} = 1.5\text{ k}\Omega$ at $OUT0$ to $OUT15$			± 0.5	± 1 %/V
ΔI_{OLC3}	Load regulation ⁽⁴⁾	All $OUTn = \text{ON}$, $V_{OUTn} = 1\text{ V}$ to 3 V , $V_{OUTfix} = 1\text{ V}$, $R_{IREF} = 1.5\text{ k}\Omega$, at $OUT0$ to $OUT15$			± 1	± 3 %/V
$T_{(PTW)}$	Pre-thermal warning threshold	Junction temperature ⁽⁵⁾	+125	+138	+150	$^\circ\text{C}$
V_{LOD}	LED open detection threshold	All $OUTn = \text{ON}$	0.25	0.30	0.35	V
V_{IREF}	Reference voltage output	$R_{IREF} = 1.5\text{ k}\Omega$	1.16	1.20	1.24	V

(1) The deviation of each output from the average of $OUT0$ – $OUT15$ constant-current. Deviation is calculated by the formula:

$$\Delta (\%) = \left[\frac{I_{OUTn}}{\frac{(I_{OUT0} + I_{OUT1} + \dots + I_{OUT14} + I_{OUT15})}{16}} - 1 \right] \times 100$$

(2) The deviation of the $OUT0$ – $OUT15$ constant-current average from the ideal constant-current value. Deviation is calculated by the following formula:

$$\Delta (\%) = \left[\frac{\frac{(I_{OUT0} + I_{OUT1} + \dots + I_{OUT14} + I_{OUT15})}{16} - (\text{Ideal Output Current})}{\text{Ideal Output Current}} \right] \times 100$$

Ideal current is calculated by the formula:

$$I_{OUT(\text{IDEAL})} = 42 \times \left[\frac{1.20}{R_{IREF}} \right]$$

(3) Line regulation is calculated by this equation:

$$\Delta (\%/V) = \left[\frac{(I_{OUTn} \text{ at } V_{CC} = 5.5\text{ V}) - (I_{OUTn} \text{ at } V_{CC} = 3.0\text{ V})}{(I_{OUTn} \text{ at } V_{CC} = 3.0\text{ V})} \right] \times \frac{100}{5.5\text{ V} - 3\text{ V}}$$

(4) Load regulation is calculated by the equation:

$$\Delta (\%/V) = \left[\frac{(I_{OUTn} \text{ at } V_{OUTn} = 3\text{ V}) - (I_{OUTn} \text{ at } V_{OUTn} = 1\text{ V})}{(I_{OUTn} \text{ at } V_{OUTn} = 1\text{ V})} \right] \times \frac{100}{3\text{ V} - 1\text{ V}}$$

(5) Not tested. Specified by design.

SWITCHING CHARACTERISTICS

At $V_{CC} = 3.0\text{ V to }5.5\text{ V}$, $T_A = -40^\circ\text{C to }+85^\circ\text{C}$, $C_L = 15\text{ pF}$, $R_L = 130\ \Omega$, $R_{REF} = 1.5\text{ k}\Omega$, and $V_{LED} = 5.5\text{ V}$. Typical values at $V_{CC} = 3.3\text{ V}$ and $T_A = +25^\circ\text{C}$, unless otherwise noted.

PARAMETER		TEST CONDITIONS	TLC5928			UNIT
			MIN	TYP	MAX	
t_{R0}	Rise time	SOUT (see Figure 5)		5	15	ns
t_{R1}		OUTn (see Figure 4)		10	30	ns
t_{F0}	Fall time	SOUT (see Figure 5)		5	15	ns
t_{F1}		OUTn (see Figure 4)		10	30	ns
t_{D0}	Propagation delay time	SCLK \uparrow to SOUT		8	20	ns
t_{D1}		LAT \uparrow or BLANK \downarrow to OUTn sink current on (see Figure 10)		12	30	ns
t_{D2}		LAT \uparrow or BLANK \uparrow to OUTn sink current off (see Figure 10)		12	30	ns
t_{ON_ERR}	Output on-time error ⁽¹⁾	On/off latch data = all '1', 20 ns BLANK low level one-shot pulse input (see Figure 4)	-8		+8	ns

(1) Output on-time error (t_{ON_ERR}) is calculated by the formula: $t_{ON_ERR}\text{ (ns)} = t_{OUT_ON} - \text{BLANK low level one-shot pulse width (}T_{WL2}\text{)}$. t_{OUT_ON} indicates the actual on-time of the constant-current driver.

FUNCTIONAL BLOCK DIAGRAM

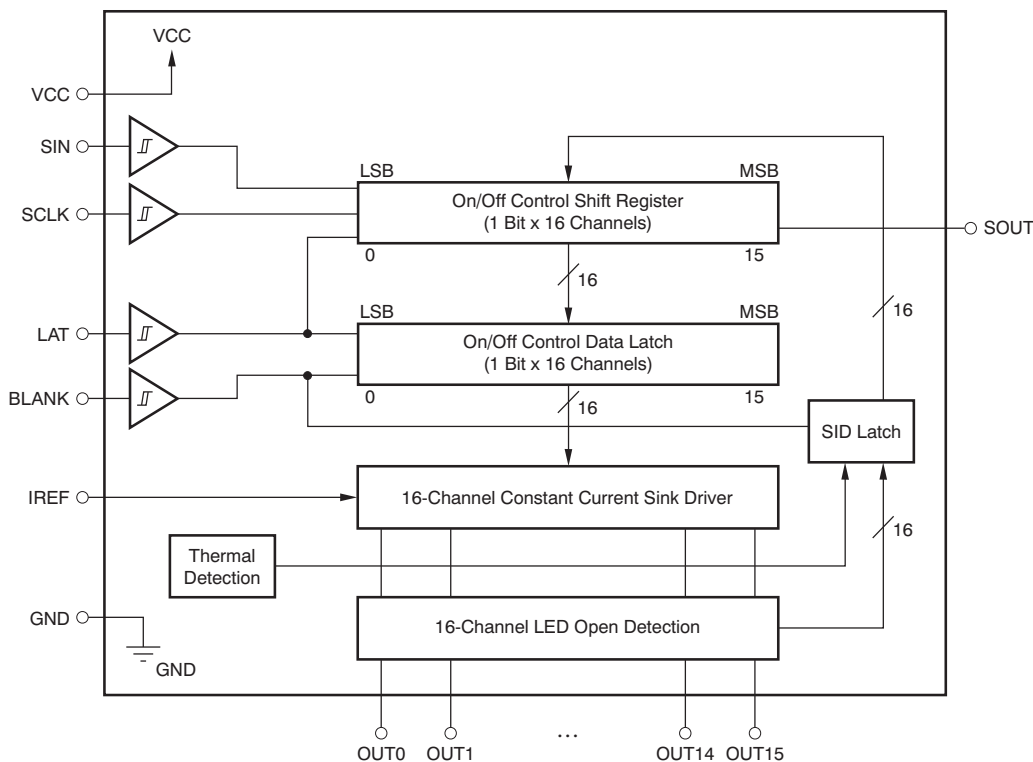

DEVICE INFORMATION

**SSOP-24/QSOP-24 AND TSSOP-24
DBQ AND PW PACKAGES
(TOP VIEW)**

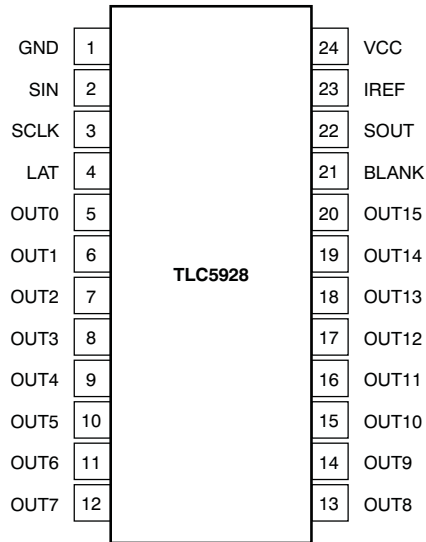

**HTSSOP-24 PowerPAD
PWP PACKAGE
(TOP VIEW)**

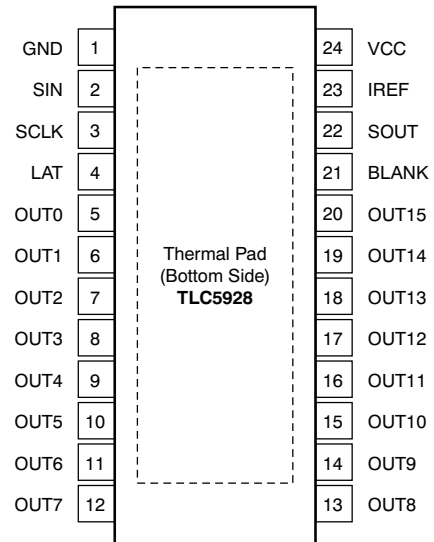

**QFN-24
RGE PACKAGE
(TOP VIEW)**

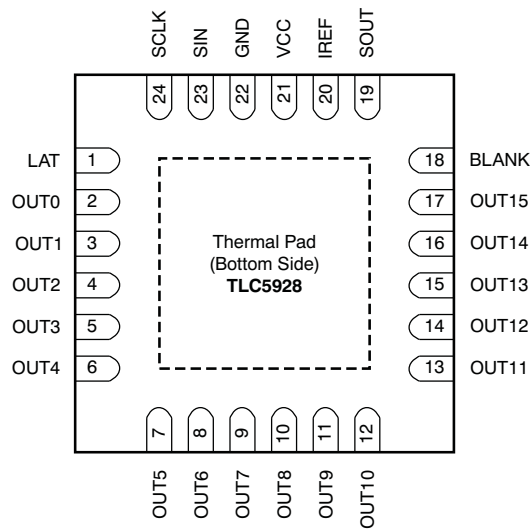

NOTE: Thermal pad is not connected to GND internally. The thermal pad must be connected to GND via the PCB pattern.

TERMINAL FUNCTIONS

TERMINAL			I/O	DESCRIPTION
NAME	DBQ/PW/PWP	RGE		
SIN	2	23	I	Serial data input for driver on/off control. When SIN = high level, data '1' are written into LSB of the on/off control shift register at the rising edge of SCLK.
SCLK	3	24	I	Serial data shift clock. Schmitt buffer input. All data in the on/off control shift register are shifted toward the MSB by 1-bit synchronization of SCLK. A rising edge on SCLK is allowed 100 ns after a rising edge of LAT.
LAT	4	1	I	Edge triggered latch. The data in the on/off control data shift register are transferred to the on/off control data latch at this rising edge. At the same time, the data in the on/off control shift register are replaced with LED open detection (LOD) and pre-thermal warning (PTW) data. LAT must be toggled only once after the shift data are updated to avoid the on/off control latch data being replaced with LOD and PTW data in the shift register.
BLANK	21	18	I	Blank, all outputs. When BLANK = high level, all constant-current outputs (OUT0–OUT15) are forced off. When BLANK = low level, all constant-current outputs are controlled by the on/off control data in the data latch. LOD and PTW data are latched into the SID data latch at the rising edge of BLANK and are present at the output of the SID data latch when BLANK is low.
IREF	23	20	I/O	Constant-current value setting, OUT0–OUT15 sink constant-current is set to desired value by connection to an external resistor between IREF and GND.
SOUT	22	19	O	Serial data output. This output is connected to the MSB of the on/off data shift register. SOUT data changes at the rising edge of SCLK.
OUT0	5	2	O	Constant-current output. Each output can be tied together with others to increase the constant-current. Different voltages can be applied to each output.
OUT1	6	3	O	Constant-current output
OUT2	7	4	O	Constant-current output
OUT3	8	5	O	Constant-current output
OUT4	9	6	O	Constant-current output
OUT5	10	7	O	Constant-current output
OUT6	11	8	O	Constant-current output
OUT7	12	9	O	Constant-current output
OUT8	13	10	O	Constant-current output
OUT9	14	11	O	Constant-current output
OUT10	15	12	O	Constant-current output
OUT11	16	13	O	Constant-current output
OUT12	17	14	O	Constant-current output
OUT13	18	15	O	Constant-current output
OUT14	19	16	O	Constant-current output
OUT15	20	17	O	Constant-current output
VCC	24	21	—	Power-supply voltage
GND	1	22	—	Power ground

PARAMETER MEASUREMENT INFORMATION

PIN EQUIVALENT INPUT AND OUTPUT SCHEMATIC DIAGRAMS

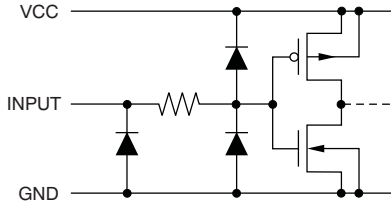

Figure 1. SIN, SCLK, LAT, BLANK

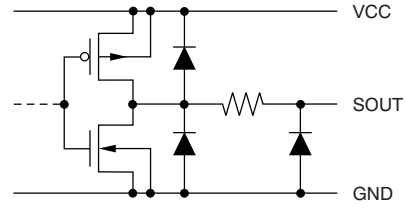

Figure 2. SOUT

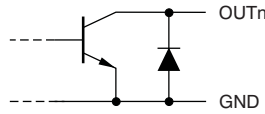
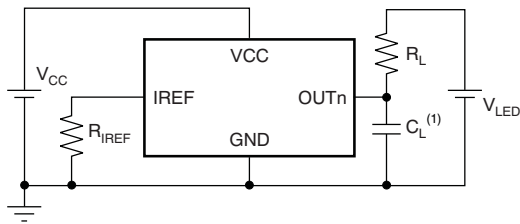

Figure 3. OUT0 Through OUT15

TEST CIRCUITS



(1) C_L includes measurement probe and jig capacitance.

Figure 4. Rise Time and Fall Time Test Circuit for OUTn

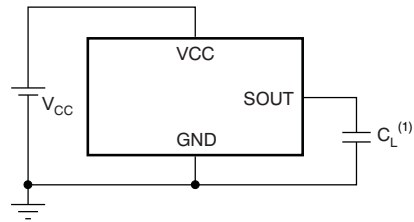

(1) C_L includes measurement probe and jig capacitance.

Figure 5. Rise Time and Fall Time Test Circuit for SOUT

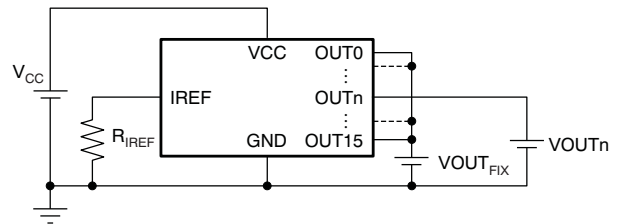
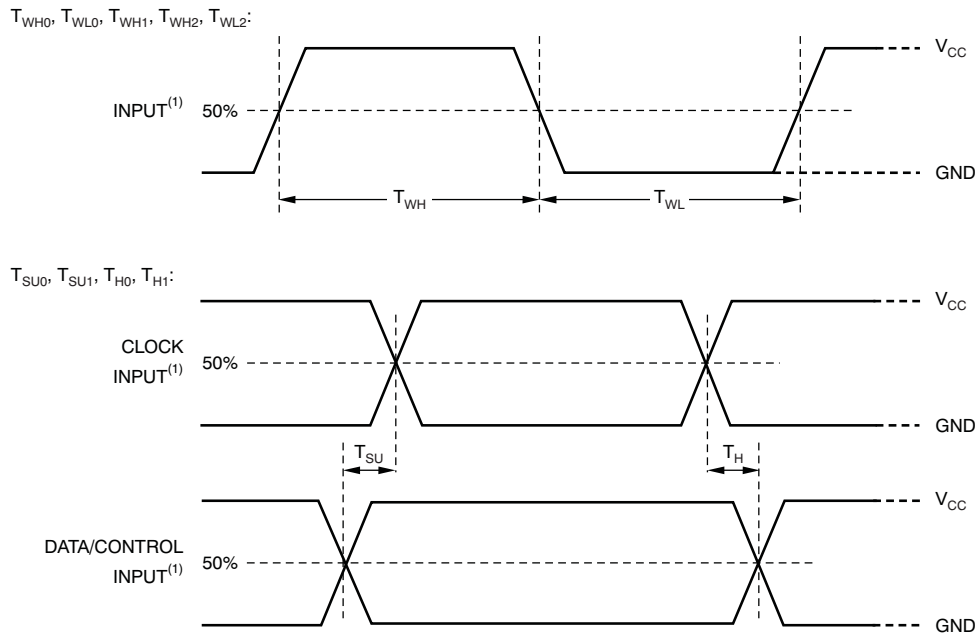

Figure 6. Constant-Current Test Circuit for OUTn

TIMING DIAGRAMS



(1) Input pulse rise and fall time is 1 ns to 3 ns.

Figure 7. Input Timing

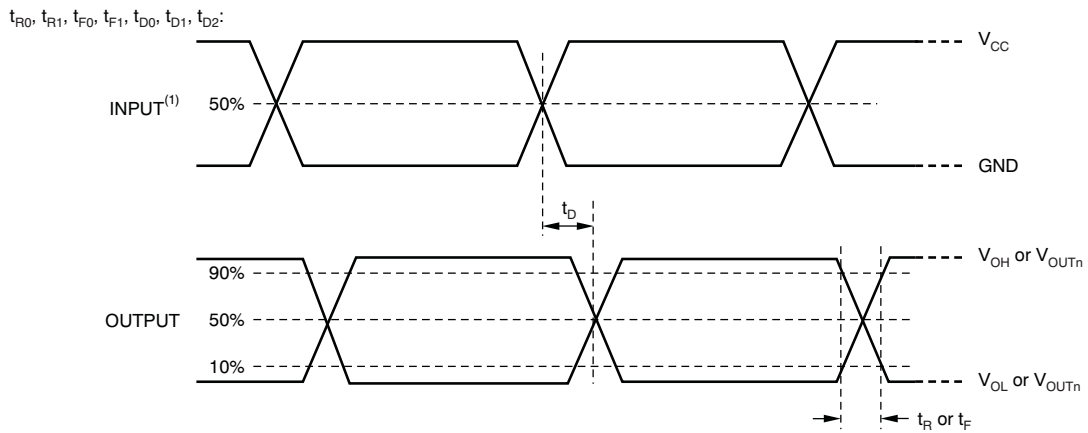

(1) Input pulse rise and fall time is 1 ns to 3 ns.

Figure 8. Output Timing

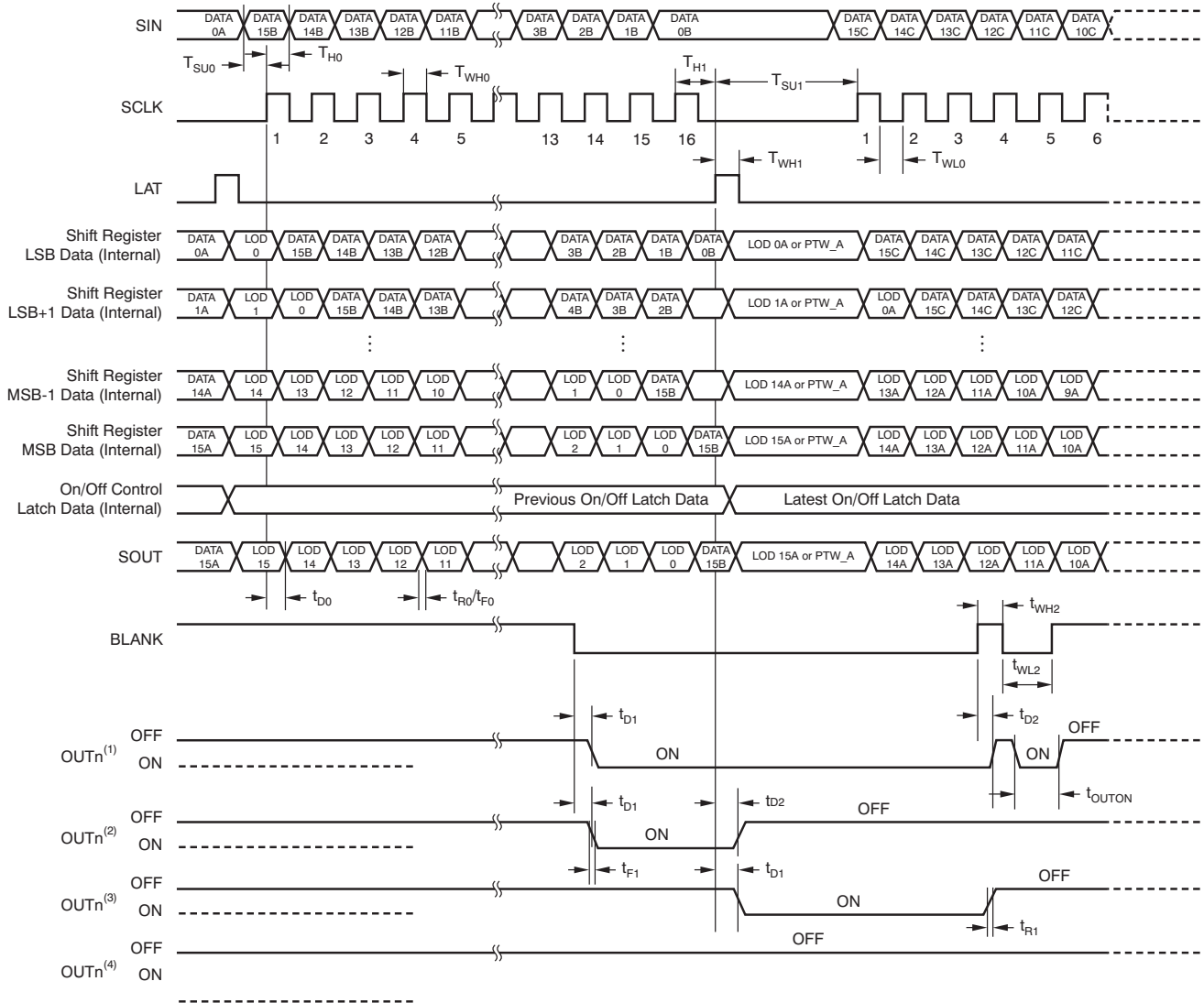

- (1) On/off latched data are '1'.
- (2) On/off latched data are changed from '1' to '0' at the second LAT signal.
- (3) On/off latched data are changed from '0' to '1' at the second LAT signal.
- (4) On/off latched data are '0'.

Figure 9. Timing Diagram

TYPICAL CHARACTERISTICS

At $V_{CC} = 3.3\text{ V}$ and $T_A = +25^\circ\text{C}$, unless otherwise noted.

REFERENCE RESISTOR vs OUTPUT CURRENT

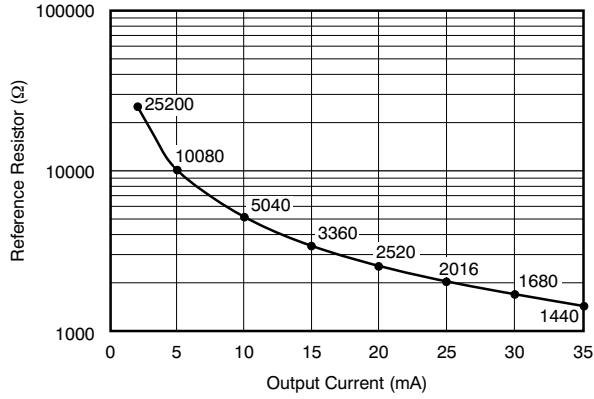

Figure 10.

POWER DISSIPATION RATE vs FREE-AIR TEMPERATURE

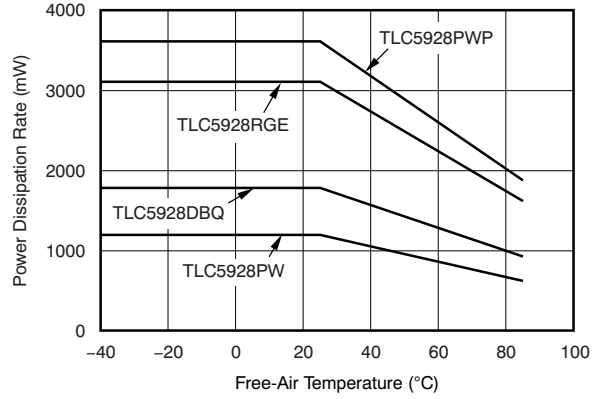

Figure 11.

OUTPUT CURRENT vs OUTPUT VOLTAGE

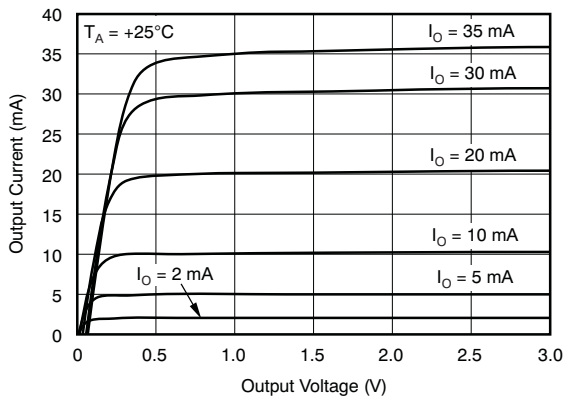

Figure 12.

OUTPUT CURRENT vs OUTPUT VOLTAGE

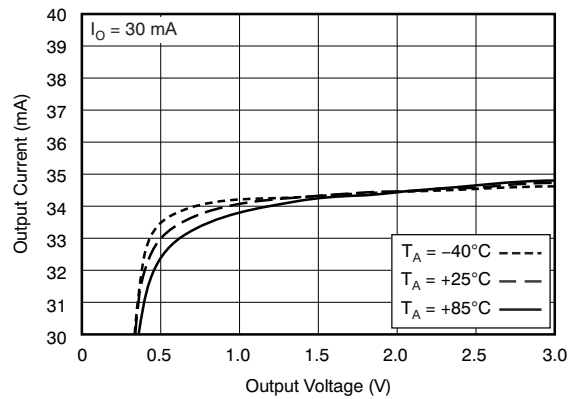

Figure 13.

ΔI_{OLC} vs AMBIENT TEMPERATURE

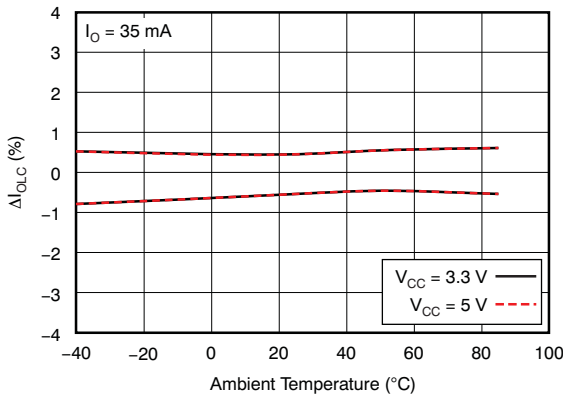

Figure 14.

ΔI_{OLC} vs OUTPUT CURRENT

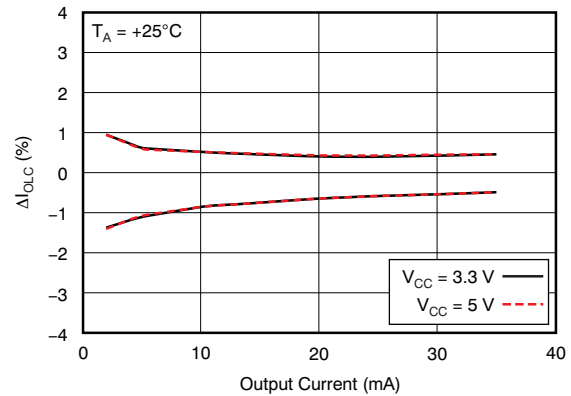

Figure 15.

TYPICAL CHARACTERISTICS (continued)

At $V_{CC} = 3.3\text{ V}$ and $T_A = +25^\circ\text{C}$, unless otherwise noted.

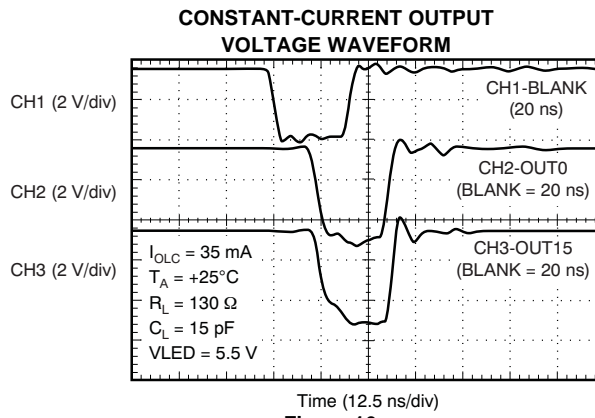

Figure 16.

DETAILED DESCRIPTION

SETTING FOR THE CONSTANT SINK CURRENT VALUE

The constant-current values are determined by an external resistor (R_{IREF}) placed between IREF and GND. The resistor (R_{IREF}) value is calculated by [Equation 1](#).

$$R_{IREF} (k\Omega) = \frac{V_{IREF} (V)}{I_{OLC} (mA)} \times 42$$

Where:

$$V_{IREF} = \text{the internal reference voltage on the IREF pin (typically 1.20 V)} \quad (1)$$

I_{OLC} must be set in the range of 2 mA to 35 mA. The constant sink current characteristic for the external resistor value is shown in [Figure 10](#). [Table 1](#) describes the constant-current output versus external resistor value.

Table 1. Constant-Current Output versus External Resistor Value

I_{OLCMax} (mA, Typical)	R_{IREF} (k Ω)
35	1.44
30	1.68
25	2.02
20	2.52
15	3.36
10	5.04
5	10.1
2	25.2

CONSTANT-CURRENT DRIVER ON/OFF CONTROL

When BLANK is low, the corresponding output is turned on if the data in the on/off control data latch are '1' and remains off if the data are '0'. When BLANK is high, all outputs are forced off. This control is shown in [Table 2](#).

Table 2. On/Off Control Data Truth Table

ON/OFF CONTROL LATCH DATA	CONSTANT-CURRENT OUTPUT STATUS
0	Off
1	On

When the IC is initially powered on, the data in the on/off control shift register and data latch are not set to the respective default value. Therefore, the on/off control data must be written to the data latch before turning the constant-current output on. BLANK should be at a high level when powered on because the constant-current may be turned on as a result of random data in the on/off control latch.

The on/off data corresponding to any unconnected OUTn outputs should be set to '0' before turning on the remaining outputs. Otherwise, the supply current (I_{CC}) increases while the LEDs are on.

REGISTER CONFIGURATION

The TLC5928 has an on/off control data shift register and data latch. Both the on/off control shift register and latch are 16 bits long and are used to turn on/off the constant-current drivers. Figure 17 shows the shift register and latch configuration. The data at the SIN pin are shifted in to the LSB of the shift register at the rising edge of the SCLK pin; SOUT data change at the rising edge of SCLK. The timing diagram for data writing is shown in Figure 18. The driver on/off is controlled by the data in the on/off control data latch.

The on/off data are latched into the data latch by a rising edge of LAT after the data are written into the on/off control shift register by SIN and SCLK. At the same time, the data in the on/off control shift register are replaced with LED open detection (LOD) and pre-thermal warning (PTW) data. Therefore, LAT must be input only once after the on/off data update to avoid the on/off control data latch being replaced with LOD and PTW data in the shift register. When the IC is initially powered on, the data in the on/off control shift register and latch are not set to the default values; on/off control data must be written to the on/off control data latch before turning the constant-current output on. BLANK should be high when the IC is powered on because the constant-current may be turned on at that time as a result of random values in the on/off data latch. All constant-current outputs are forced off when BLANK is high.

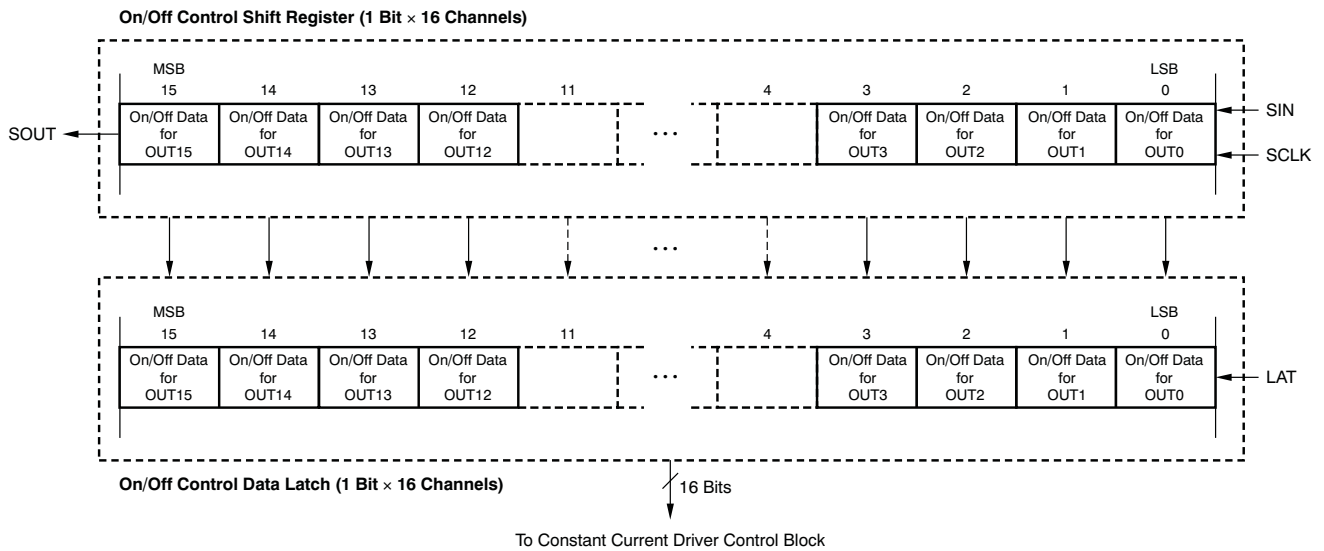
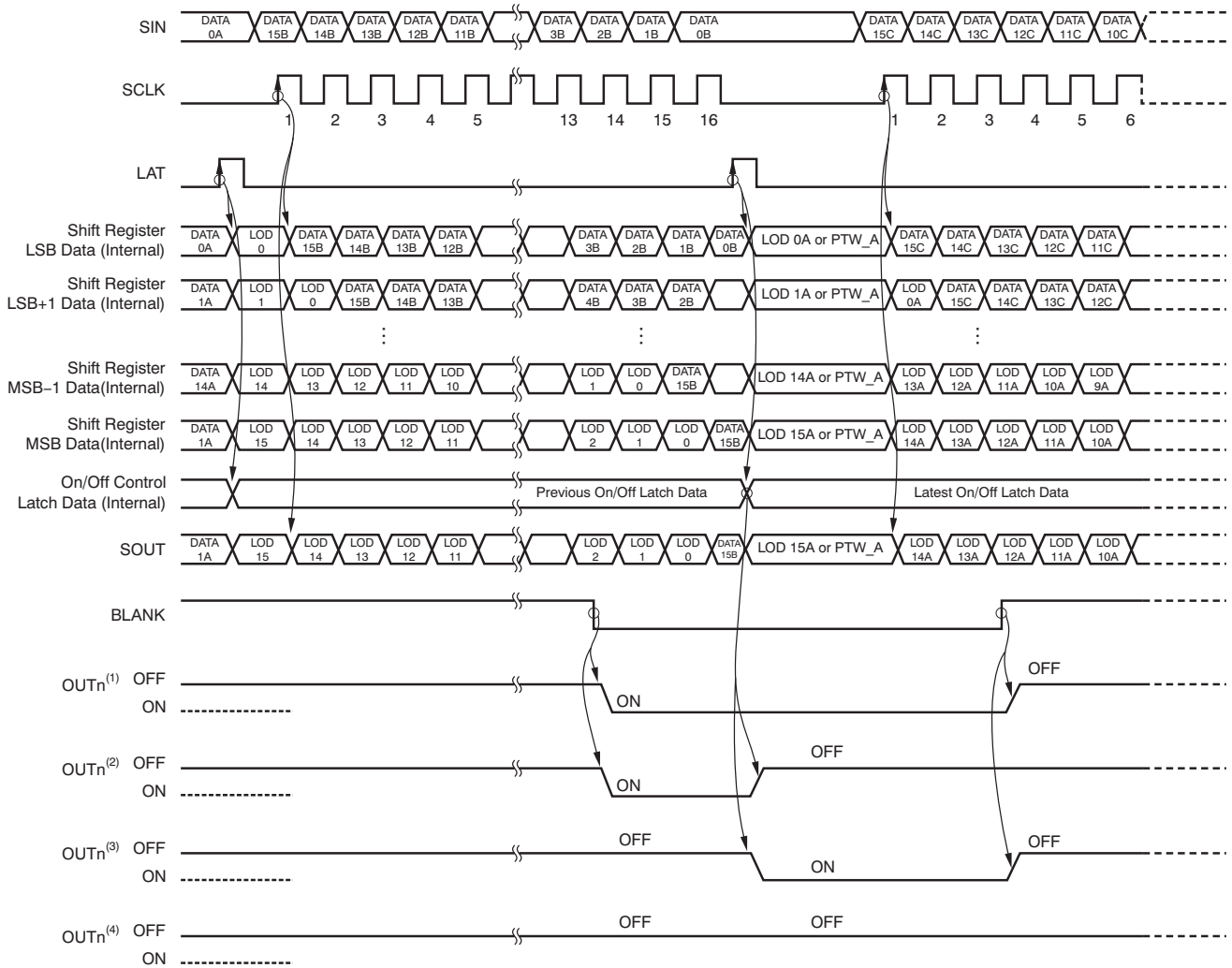

Figure 17. On/Off Control Shift Register and Latch Configuration



- (1) On/off latched data are '1'.
- (2) On/off latched data are changed from '1' to '0' at the second LAT signal.
- (3) On/off latched data are changed from '0' to '1' at the second LAT signal.
- (4) On/off latched data are '0'.

Figure 18. On/Off Control Operation

LED OPEN DETECTION (LOD) AND PRE-THERMAL WARNING (PTW)

The LED open detection (LOD) circuit checks the voltage of each active (that is, on) constant-current sink output (OUT0 through OUT15) to detect open LEDs and LEDs shorted to GND while BLANK is low. The LOD bits in the status information data register (SID) are set to '1' if the voltage of the corresponding OUTn pin is less than the LED open detection threshold ($V_{LOD} = 0.3\text{ V}$, typ). The status information data can be read from the SOUT pin. To avoid false detection of open LEDs, the LED driver design must ensure that the constant-current sink output voltage is greater than 0.3 V when the outputs are on. Also, the output on-time must be 1 μs or greater to correctly read the valid LOD status.

The PTW function indicates that the IC junction temperature is too high. The PTW bit in the SID data is set to '1' while the IC junction temperature exceeds the temperature threshold ($T_{(PTW)} = +138\text{ }^\circ\text{C}$, typ). If the IC junction temperature decreases below the temperature of $T_{(PTW)}$, the SID data are set depending on the LOD function. The constant-current outputs are not forced off during PTW conditions, so the controller should take appropriate action (such as reducing the duty cycle of effected channels).

The LOD and PTW data are latched into the SID latch with the rising edge of BLANK and do not change until BLANK goes low. The SID data latched in the latch are transferred into the on/off shift register with a rising edge of LAT. SID can be shifted out from SOUT with rising edges of SCLK. The data in the on/off control shift register are replaced with the LOD and PTW data at the rising edge of LAT. Therefore, LAT should be input only once after the shift data are updated to avoid the on/off control data latch information from being replaced with LOD and PTW data in the shift register. A timing diagram for LOD, PTW, and SID is shown in Figure 19.

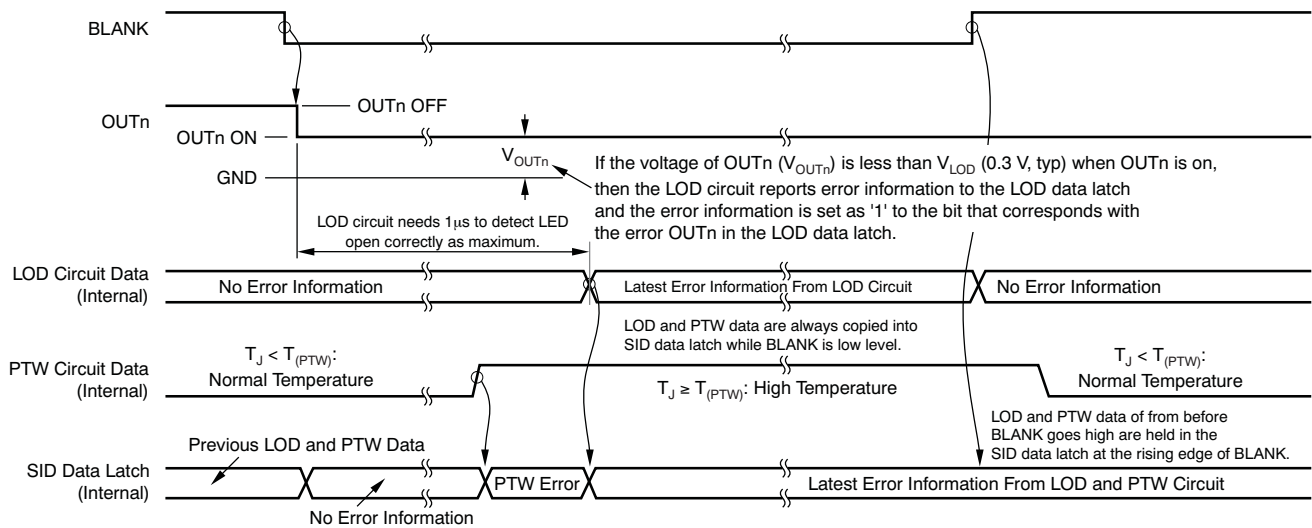

Figure 19. LOD/PTW/SID timing

STATUS INFORMATION DATA (SID)

The latched LED open detection (LOD) error and pre-thermal warning (PTW) in the SID data latch are shifted out onto the SOUT pin with each rising edge of SCLK. If a PTW is reported, all LOD error bits are set to '1'. The SID data are written over the data in the on/off control shift register at the rising edge of LAT. Therefore, the previous data in the on/off control shift register are lost when SID information is latched in. Figure 20 shows the SID bit assignments. See Figure 7 for the read timing of SID.

When the IC is powered on, the initial LOD data are invalid. Therefore, LOD data must be read after the rising edge of BLANK. Table 3 shows a truth table for LOD and PTW.

Table 3. LOD and PTW Truth Table

	CONDITION	SID DATA
LED open detection (LODn)	LED is connected ($V_{OUTn} > V_{LOD}$)	'0' (low level at SOUT)
	LED is opened or shorted to GND ($V_{OUTn} \leq V_{LOD}$ and output on)	'1' (high level at SOUT); set to the bit that has an LED error condition
Pre-thermal warning (PTW)	IC temperature is low (IC temperature $\leq T_{(PTW)}$)	Depend LED open error
	IC temperature is high (IC temperature $> T_{(PTW)}$)	All bits = '1' (high level at SOUT)

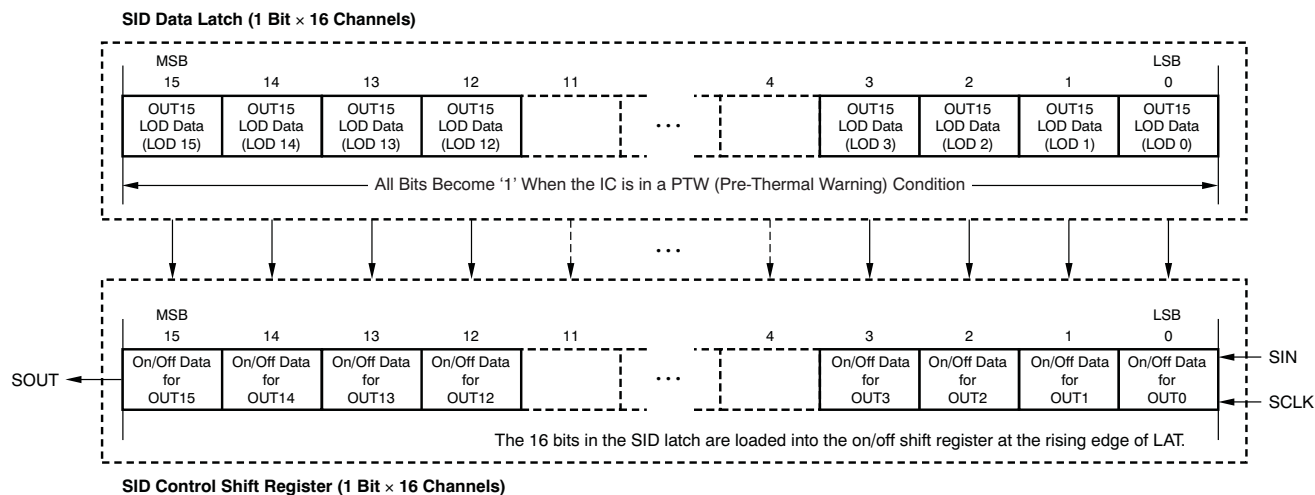

Figure 20. Status Information Data Configuration

LAYOUT CONSIDERATIONS

The output current transient time in the TLC5928 is very fast. In addition, all outputs turn on or off at the same time to minimize the output on-time error. This high current demand can cause GND to shift in the entire system, and lead to false triggering of signals. To overcome this issue, design all GND lines to be as wide and short as possible in order to reduce parasitic inductance and resistance.

REVISION HISTORY

NOTE: Page numbers for previous revisions may differ from page numbers in the current version.

Changes from Revision D (August 2010) to Revision E	Page
• Added <i>Layout Considerations</i> section	17

Changes from Revision C (November 2008) to Revision D	Page
• Changed SO-24 to SSOP-24/QSOP-24 in Package/Ordering Information table	2
• Changed SO-24 to SSOP-24/QSOP-24 in Dissipation Ratings table	2
• Updated functional block diagram	5
• Changed SO-24 to SSOP-24/QSOP-24 in DBQ and PW Packages pinout	6
• Updated Figure 9	10
• Updated Figure 18	15



PACKAGING INFORMATION

Orderable Device	Status (1)	Package Type	Package Drawing	Pins	Package Qty	Eco Plan (2)	Lead/Ball Finish (6)	MSL Peak Temp (3)	Op Temp (°C)	Device Marking (4/5)	Samples
TLC5928DBQ	ACTIVE	SSOP	DBQ	24	50	Green (RoHS & no Sb/Br)	CU NIPDAU	Level-2-260C-1 YEAR	-40 to 85	TLC5928	Samples
TLC5928DBQG4	ACTIVE	SSOP	DBQ	24	50	Green (RoHS & no Sb/Br)	CU NIPDAU	Level-2-260C-1 YEAR	-40 to 85	TLC5928	Samples
TLC5928DBQR	ACTIVE	SSOP	DBQ	24	2500	Green (RoHS & no Sb/Br)	CU NIPDAU	Level-2-260C-1 YEAR	-40 to 85	TLC5928	Samples
TLC5928PW	ACTIVE	TSSOP	PW	24	60	Green (RoHS & no Sb/Br)	CU NIPDAU	Level-1-260C-UNLIM	-40 to 85	PJ5928	Samples
TLC5928PWG4	ACTIVE	TSSOP	PW	24	60	Green (RoHS & no Sb/Br)	CU NIPDAU	Level-1-260C-UNLIM	-40 to 85	PJ5928	Samples
TLC5928PWP	ACTIVE	HTSSOP	PWP	24	60	Green (RoHS & no Sb/Br)	CU NIPDAU	Level-2-260C-1 YEAR	-40 to 85	PJ5928	Samples
TLC5928PWPR	ACTIVE	HTSSOP	PWP	24	2000	Green (RoHS & no Sb/Br)	CU NIPDAU	Level-2-260C-1 YEAR	-40 to 85	PJ5928	Samples
TLC5928PWPRG4	ACTIVE	HTSSOP	PWP	24	2000	Green (RoHS & no Sb/Br)	CU NIPDAU	Level-2-260C-1 YEAR	-40 to 85	PJ5928	Samples
TLC5928PWR	ACTIVE	TSSOP	PW	24	2000	Green (RoHS & no Sb/Br)	CU NIPDAU	Level-1-260C-UNLIM	-40 to 85	PJ5928	Samples
TLC5928RGER	ACTIVE	VQFN	RGE	24	3000	Green (RoHS & no Sb/Br)	CU NIPDAU	Level-2-260C-1 YEAR	-40 to 85	TLC 5928	Samples
TLC5928RGET	ACTIVE	VQFN	RGE	24	250	Green (RoHS & no Sb/Br)	CU NIPDAU	Level-2-260C-1 YEAR	-40 to 85	TLC 5928	Samples

(1) The marketing status values are defined as follows:

ACTIVE: Product device recommended for new designs.

LIFEBUY: TI has announced that the device will be discontinued, and a lifetime-buy period is in effect.

NRND: Not recommended for new designs. Device is in production to support existing customers, but TI does not recommend using this part in a new design.

PREVIEW: Device has been announced but is not in production. Samples may or may not be available.

OBsolete: TI has discontinued the production of the device.

(2) Eco Plan - The planned eco-friendly classification: Pb-Free (RoHS), Pb-Free (RoHS Exempt), or Green (RoHS & no Sb/Br) - please check <http://www.ti.com/productcontent> for the latest availability information and additional product content details.

TBD: The Pb-Free/Green conversion plan has not been defined.

Pb-Free (RoHS): TI's terms "Lead-Free" or "Pb-Free" mean semiconductor products that are compatible with the current RoHS requirements for all 6 substances, including the requirement that lead not exceed 0.1% by weight in homogeneous materials. Where designed to be soldered at high temperatures, TI Pb-Free products are suitable for use in specified lead-free processes.



Pb-Free (RoHS Exempt): This component has a RoHS exemption for either 1) lead-based flip-chip solder bumps used between the die and package, or 2) lead-based die adhesive used between the die and leadframe. The component is otherwise considered Pb-Free (RoHS compatible) as defined above.
Green (RoHS & no Sb/Br): TI defines "Green" to mean Pb-Free (RoHS compatible), and free of Bromine (Br) and Antimony (Sb) based flame retardants (Br or Sb do not exceed 0.1% by weight in homogeneous material)

⁽³⁾ MSL, Peak Temp. - The Moisture Sensitivity Level rating according to the JEDEC industry standard classifications, and peak solder temperature.

⁽⁴⁾ There may be additional marking, which relates to the logo, the lot trace code information, or the environmental category on the device.

⁽⁵⁾ Multiple Device Markings will be inside parentheses. Only one Device Marking contained in parentheses and separated by a "-" will appear on a device. If a line is indented then it is a continuation of the previous line and the two combined represent the entire Device Marking for that device.

⁽⁶⁾ Lead/Ball Finish - Orderable Devices may have multiple material finish options. Finish options are separated by a vertical ruled line. Lead/Ball Finish values may wrap to two lines if the finish value exceeds the maximum column width.

Important Information and Disclaimer: The information provided on this page represents TI's knowledge and belief as of the date that it is provided. TI bases its knowledge and belief on information provided by third parties, and makes no representation or warranty as to the accuracy of such information. Efforts are underway to better integrate information from third parties. TI has taken and continues to take reasonable steps to provide representative and accurate information but may not have conducted destructive testing or chemical analysis on incoming materials and chemicals. TI and TI suppliers consider certain information to be proprietary, and thus CAS numbers and other limited information may not be available for release.

In no event shall TI's liability arising out of such information exceed the total purchase price of the TI part(s) at issue in this document sold by TI to Customer on an annual basis.

TAPE AND REEL INFORMATION

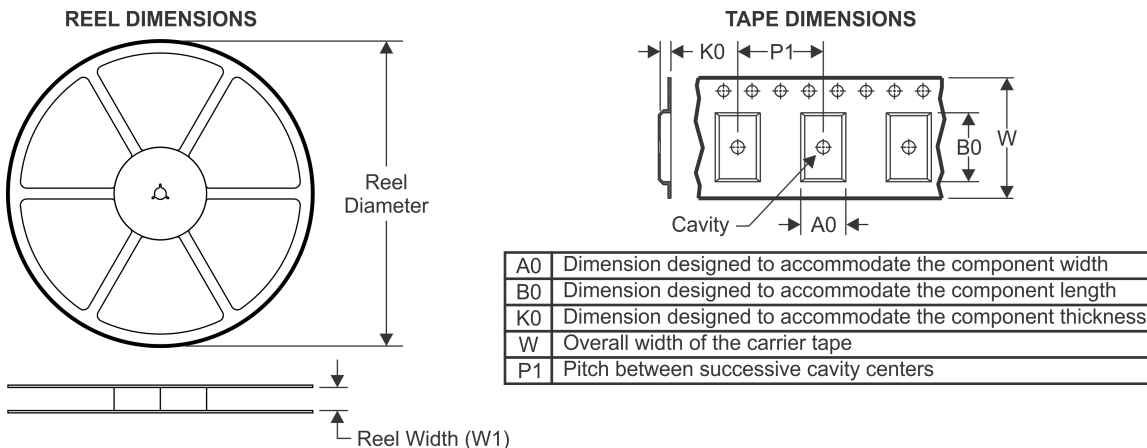

QUADRANT ASSIGNMENTS FOR PIN 1 ORIENTATION IN TAPE

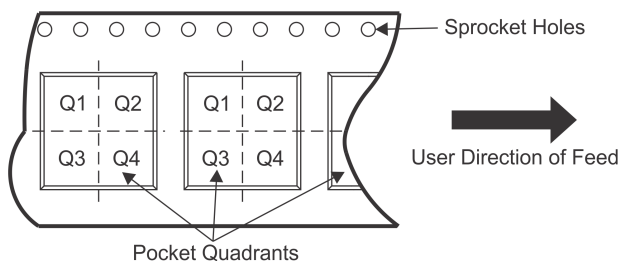

*All dimensions are nominal

Device	Package Type	Package Drawing	Pins	SPQ	Reel Diameter (mm)	Reel Width W1 (mm)	A0 (mm)	B0 (mm)	K0 (mm)	P1 (mm)	W (mm)	Pin1 Quadrant
TLC5928PWR	TSSOP	PW	24	2000	330.0	16.4	6.95	8.3	1.6	8.0	16.0	Q1
TLC5928RGER	VQFN	RGE	24	3000	330.0	12.4	4.25	4.25	1.15	8.0	12.0	Q2
TLC5928RGER	VQFN	RGE	24	3000	330.0	12.4	4.25	4.25	1.15	8.0	12.0	Q2
TLC5928RGET	VQFN	RGE	24	250	180.0	12.4	4.25	4.25	1.15	8.0	12.0	Q2
TLC5928RGET	VQFN	RGE	24	250	180.0	12.4	4.25	4.25	1.15	8.0	12.0	Q2

TAPE AND REEL BOX DIMENSIONS

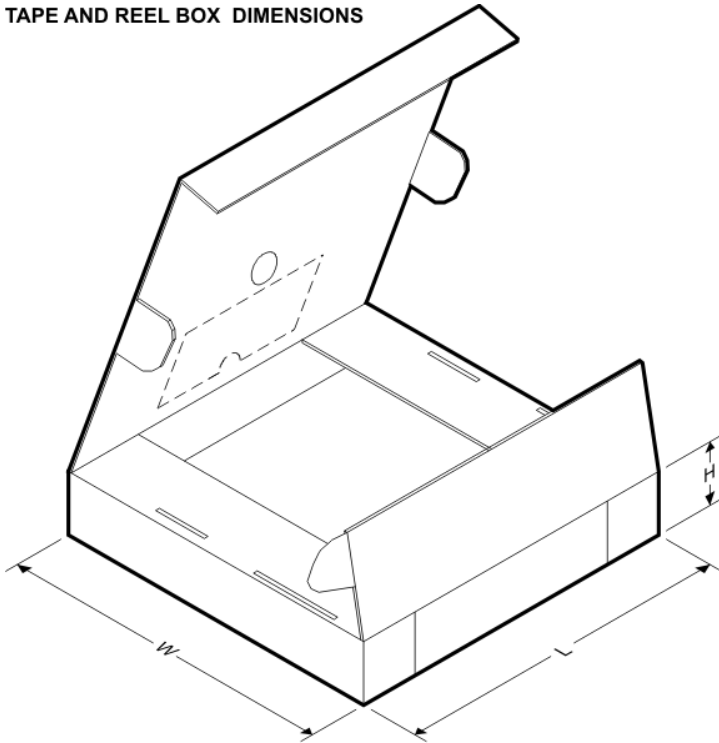

*All dimensions are nominal

Device	Package Type	Package Drawing	Pins	SPQ	Length (mm)	Width (mm)	Height (mm)
TLC5928PWR	TSSOP	PW	24	2000	367.0	367.0	38.0
TLC5928RGER	VQFN	RGE	24	3000	367.0	367.0	35.0
TLC5928RGER	VQFN	RGE	24	3000	367.0	367.0	35.0
TLC5928RGET	VQFN	RGE	24	250	210.0	185.0	35.0
TLC5928RGET	VQFN	RGE	24	250	210.0	185.0	35.0

MECHANICAL DATA

DBQ (R-PDSO-G24)

PLASTIC SMALL-OUTLINE PACKAGE

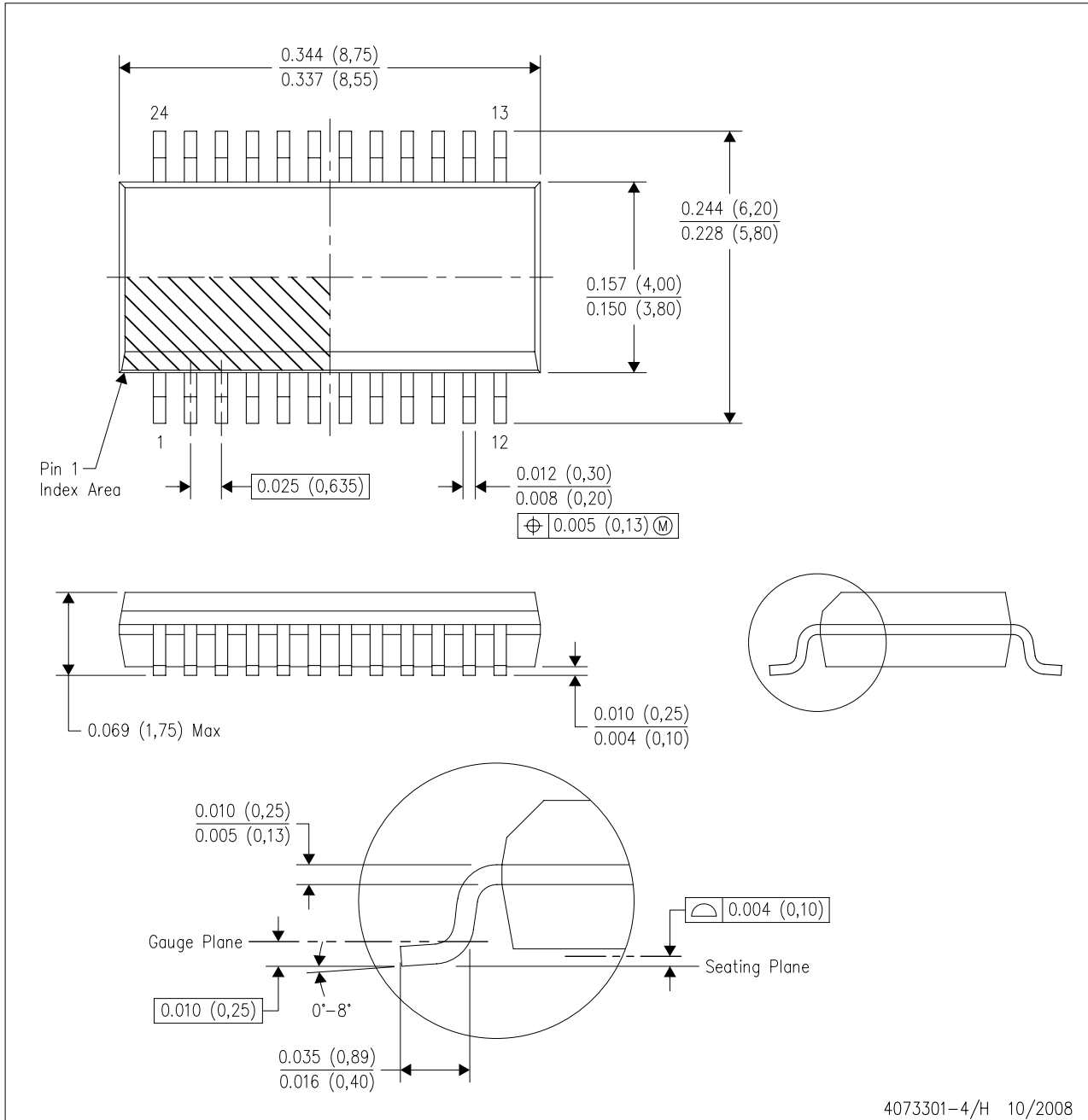

4073301-4/H 10/2008

- NOTES:
- All linear dimensions are in inches (millimeters).
 - This drawing is subject to change without notice.
 - Body dimensions do not include mold flash or protrusion not to exceed 0.006 (0,15) per side.
 - Falls within JEDEC MO-137 variation AE.

MECHANICAL DATA

PW (R-PDSO-G24)

PLASTIC SMALL OUTLINE

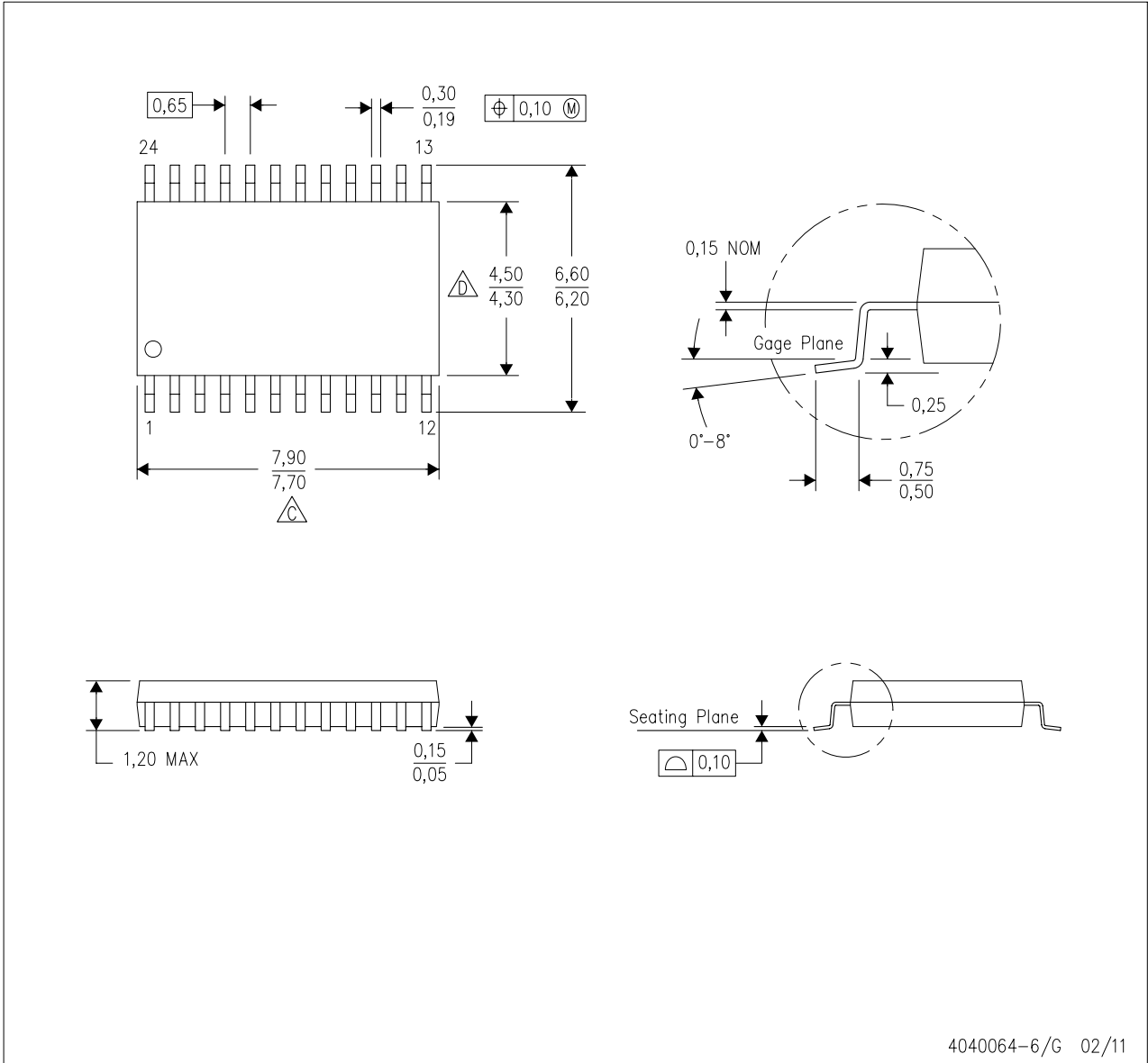

- NOTES:
- A. All linear dimensions are in millimeters. Dimensioning and tolerancing per ASME Y14.5M-1994.
 - B. This drawing is subject to change without notice.
 - Body length does not include mold flash, protrusions, or gate burrs. Mold flash, protrusions, or gate burrs shall not exceed 0,15 each side.
 - Body width does not include interlead flash. Interlead flash shall not exceed 0,25 each side.
 - E. Falls within JEDEC MO-153

LAND PATTERN DATA

PW (R-PDSO-G24)

PLASTIC SMALL OUTLINE

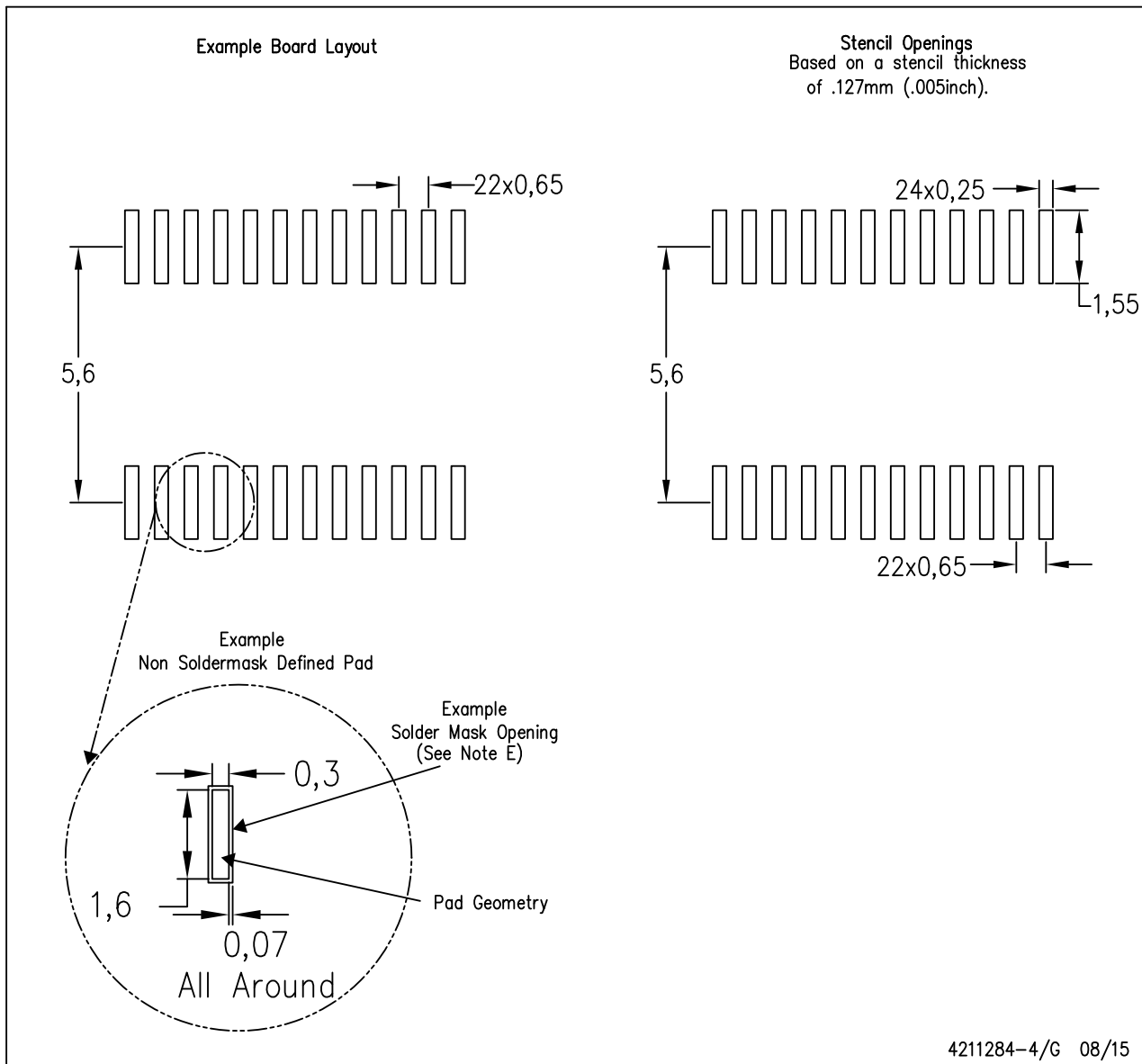

- NOTES:
- A. All linear dimensions are in millimeters.
 - B. This drawing is subject to change without notice.
 - C. Publication IPC-7351 is recommended for alternate design.
 - D. Laser cutting apertures with trapezoidal walls and also rounding corners will offer better paste release. Customers should contact their board assembly site for stencil design recommendations. Refer to IPC-7525 for other stencil recommendations.
 - E. Customers should contact their board fabrication site for solder mask tolerances between and around signal pads.

MECHANICAL DATA

PWP (R-PDSO-G24)

PowerPAD™ PLASTIC SMALL OUTLINE

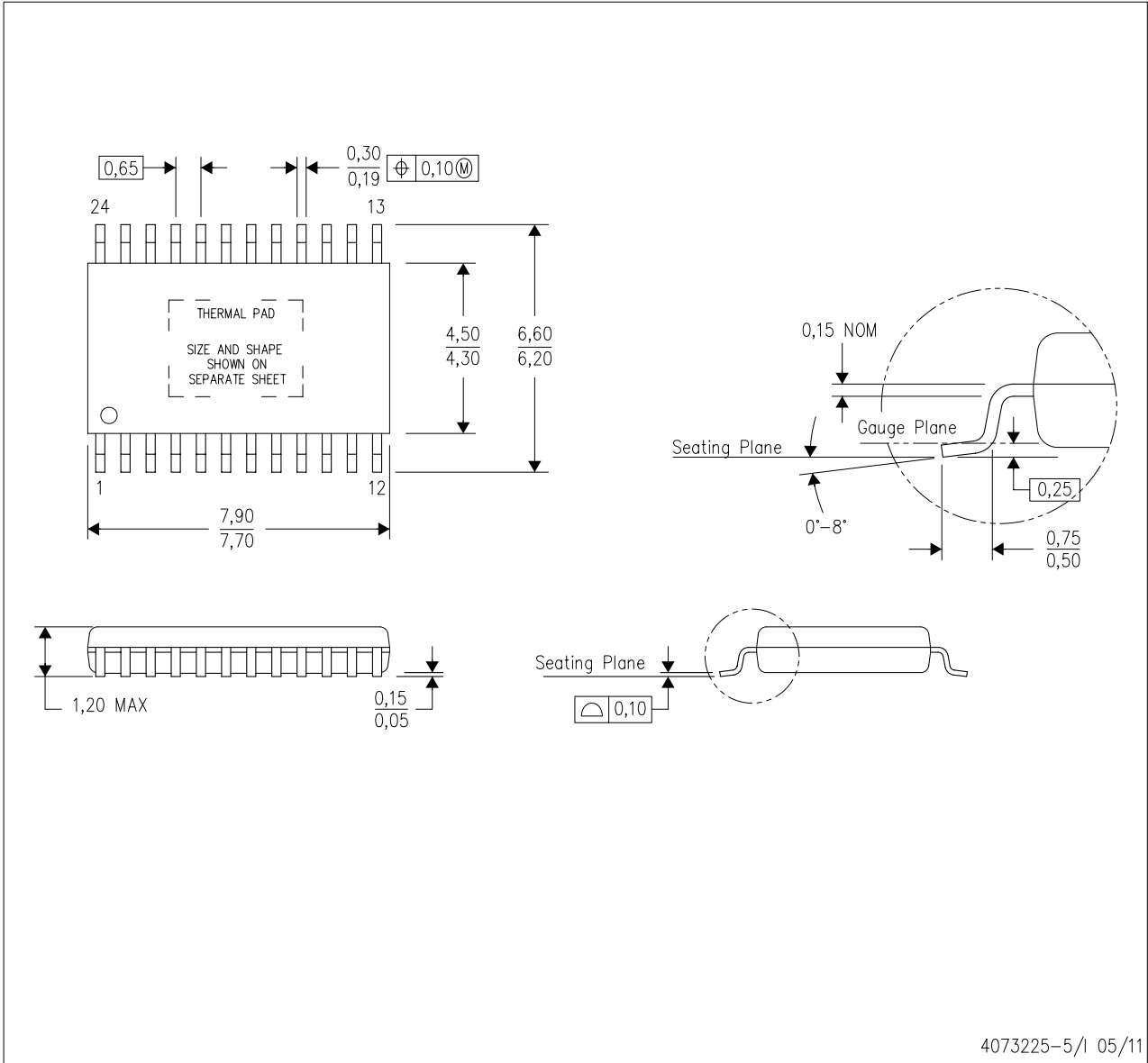

- NOTES:
- A. All linear dimensions are in millimeters.
 - B. This drawing is subject to change without notice.
 - C. Body dimensions do not include mold flash or protrusions. Mold flash and protrusion shall not exceed 0.15 per side.
 - D. This package is designed to be soldered to a thermal pad on the board. Refer to Technical Brief, PowerPad Thermally Enhanced Package, Texas Instruments Literature No. SLMA002 for information regarding recommended board layout. This document is available at www.ti.com <<http://www.ti.com>>.
 - E. See the additional figure in the Product Data Sheet for details regarding the exposed thermal pad features and dimensions.
 - F. Falls within JEDEC MO-153

PowerPAD is a trademark of Texas Instruments.

THERMAL PAD MECHANICAL DATA

PWP (R-PDSO-G24) PowerPAD™ SMALL PLASTIC OUTLINE

THERMAL INFORMATION

This PowerPAD™ package incorporates an exposed thermal pad that is designed to be attached to a printed circuit board (PCB). The thermal pad must be soldered directly to the PCB. After soldering, the PCB can be used as a heatsink. In addition, through the use of thermal vias, the thermal pad can be attached directly to the appropriate copper plane shown in the electrical schematic for the device, or alternatively, can be attached to a special heatsink structure designed into the PCB. This design optimizes the heat transfer from the integrated circuit (IC).

For additional information on the PowerPAD package and how to take advantage of its heat dissipating abilities, refer to Technical Brief, PowerPAD Thermally Enhanced Package, Texas Instruments Literature No. SLMA002 and Application Brief, PowerPAD Made Easy, Texas Instruments Literature No. SLMA004. Both documents are available at www.ti.com.

The exposed thermal pad dimensions for this package are shown in the following illustration.

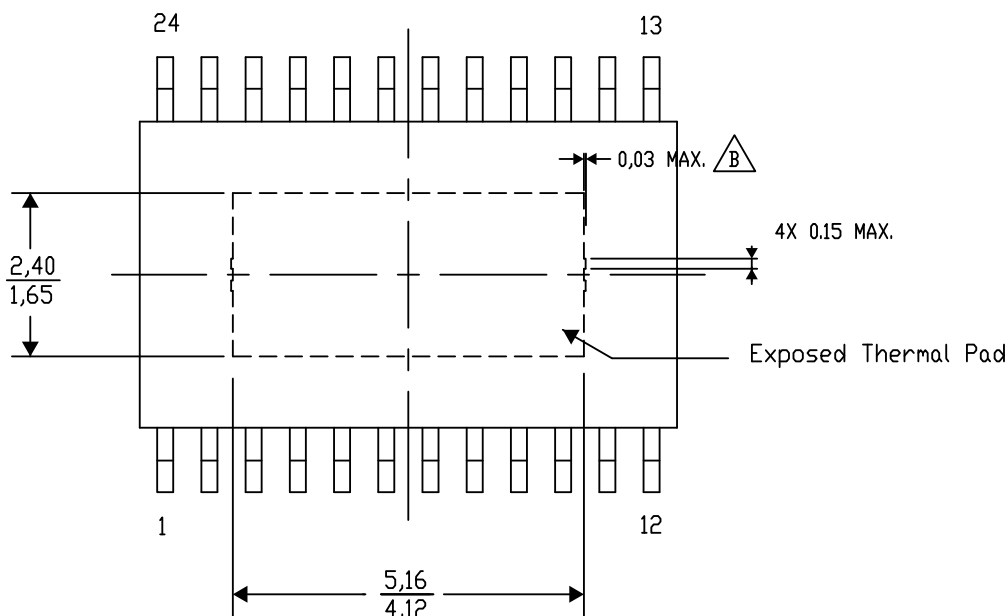

Top View

Exposed Thermal Pad Dimensions

4206332-29/AO 01/16

NOTE: A. All linear dimensions are in millimeters
 B. Exposed tie strap features may not be present.

PowerPAD is a trademark of Texas Instruments

LAND PATTERN DATA

PWP (R-PDSO-G24)

PowerPAD™ PLASTIC SMALL OUTLINE

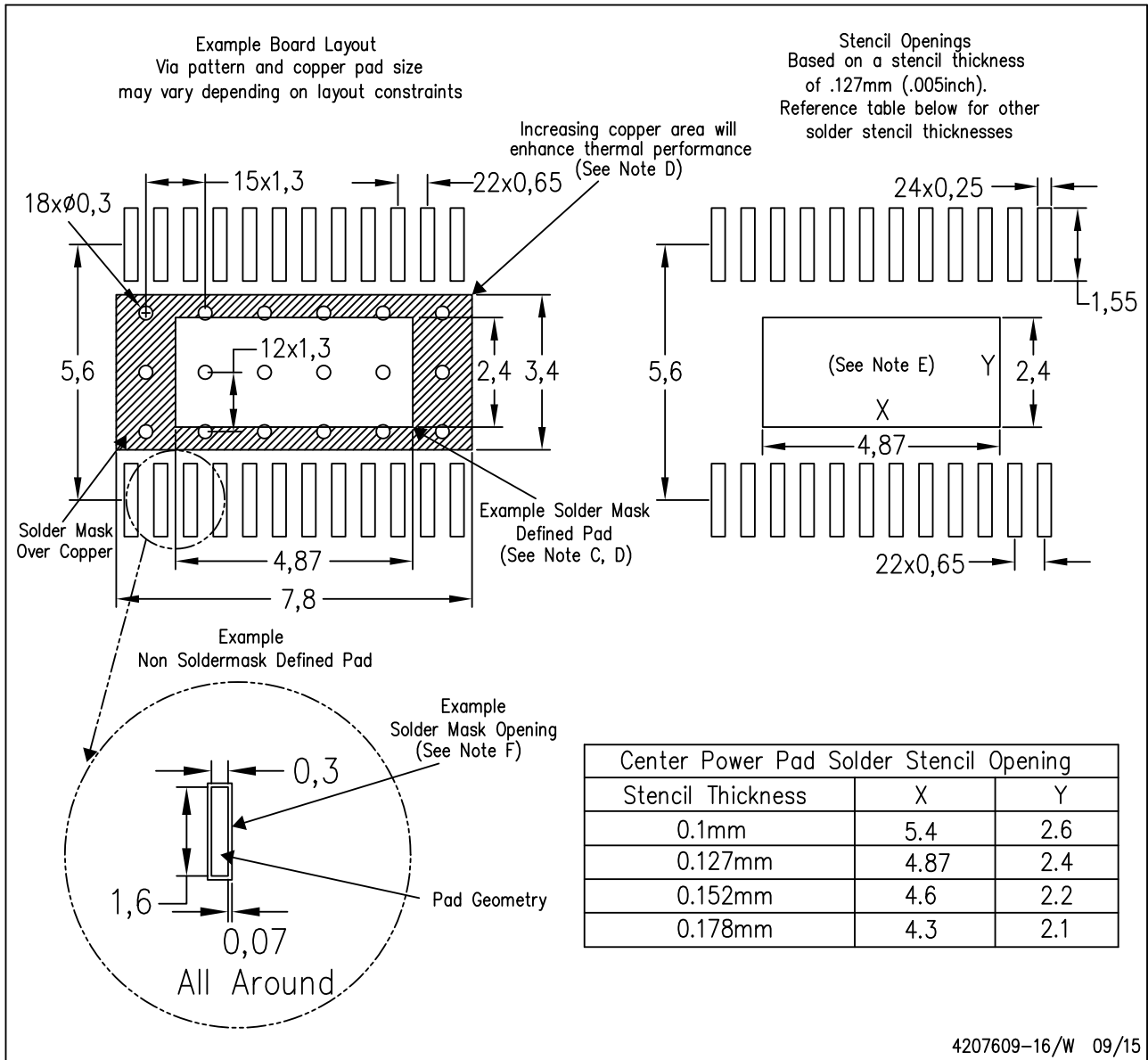

- NOTES:
- All linear dimensions are in millimeters.
 - This drawing is subject to change without notice.
 - Customers should place a note on the circuit board fabrication drawing not to alter the center solder mask defined pad.
 - This package is designed to be soldered to a thermal pad on the board. Refer to Technical Brief, PowerPad Thermally Enhanced Package, Texas Instruments Literature No. SLMA002, SLMA004, and also the Product Data Sheets for specific thermal information, via requirements, and recommended board layout. These documents are available at www.ti.com <<http://www.ti.com>>. Publication IPC-7351 is recommended for alternate designs.
 - Laser cutting apertures with trapezoidal walls and also rounding corners will offer better paste release. Customers should contact their board assembly site for stencil design recommendations. Example stencil design based on a 50% volumetric metal load solder paste. Refer to IPC-7525 for other stencil recommendations.
 - Customers should contact their board fabrication site for solder mask tolerances between and around signal pads.

MECHANICAL DATA

RGE (S-PVQFN-N24)

PLASTIC QUAD FLATPACK NO-LEAD

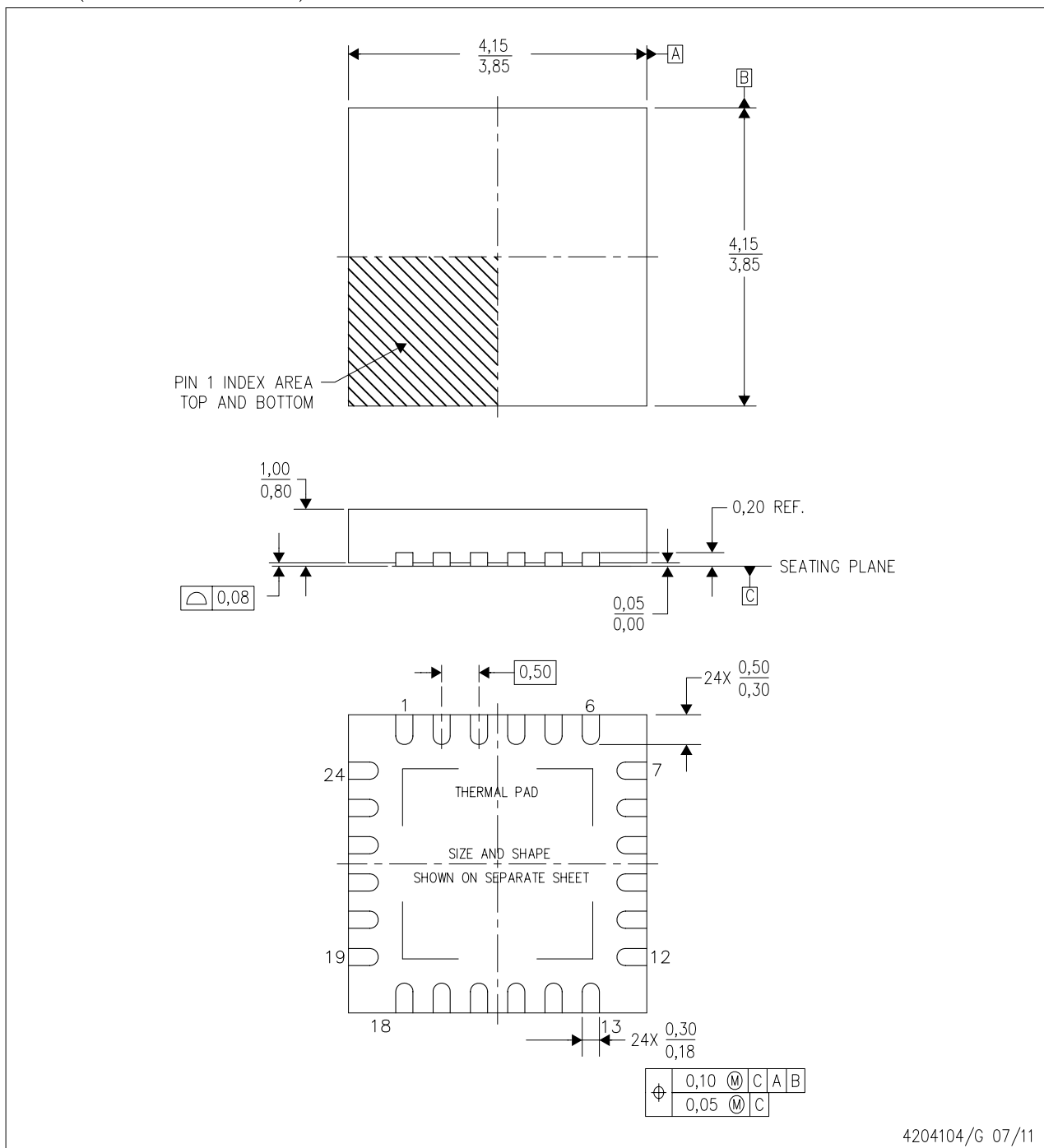

4204104/G 07/11

- NOTES:
- All linear dimensions are in millimeters. Dimensioning and tolerancing per ASME Y14.5M-1994.
 - This drawing is subject to change without notice.
 - Quad Flatpack, No-Leads (QFN) package configuration.
 - The package thermal pad must be soldered to the board for thermal and mechanical performance.
 - See the additional figure in the Product Data Sheet for details regarding the exposed thermal pad features and dimensions.
 - Falls within JEDEC MO-220.

THERMAL PAD MECHANICAL DATA

RGE (S-PVQFN-N24)

PLASTIC QUAD FLATPACK NO-LEAD

THERMAL INFORMATION

This package incorporates an exposed thermal pad that is designed to be attached directly to an external heatsink. The thermal pad must be soldered directly to the printed circuit board (PCB). After soldering, the PCB can be used as a heatsink. In addition, through the use of thermal vias, the thermal pad can be attached directly to the appropriate copper plane shown in the electrical schematic for the device, or alternatively, can be attached to a special heatsink structure designed into the PCB. This design optimizes the heat transfer from the integrated circuit (IC).

For information on the Quad Flatpack No-Lead (QFN) package and its advantages, refer to Application Report, QFN/SON PCB Attachment, Texas Instruments Literature No. SLUA271. This document is available at www.ti.com.

The exposed thermal pad dimensions for this package are shown in the following illustration.

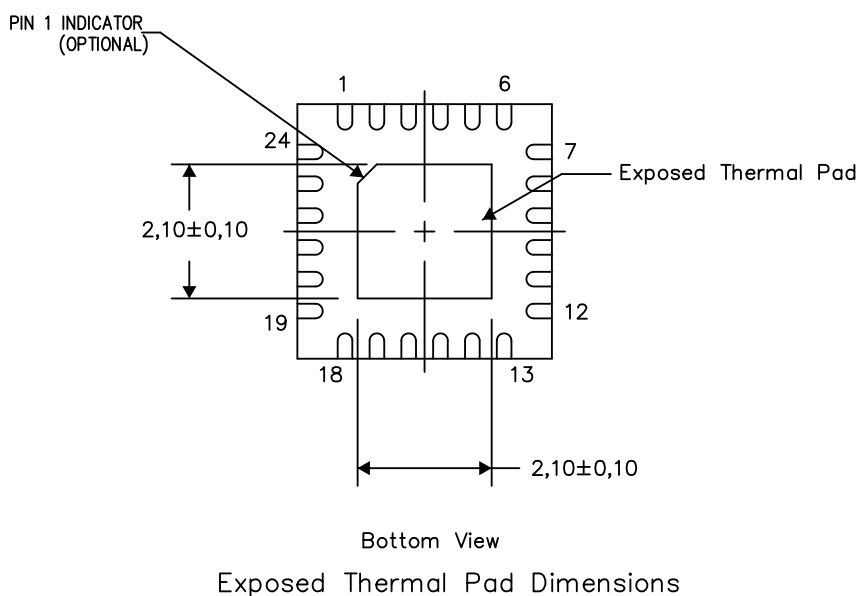

4206344-7/AK 08/15

NOTES: A. All linear dimensions are in millimeters

LAND PATTERN DATA

RGE (S-PVQFN-N24)

PLASTIC QUAD FLATPACK NO-LEAD

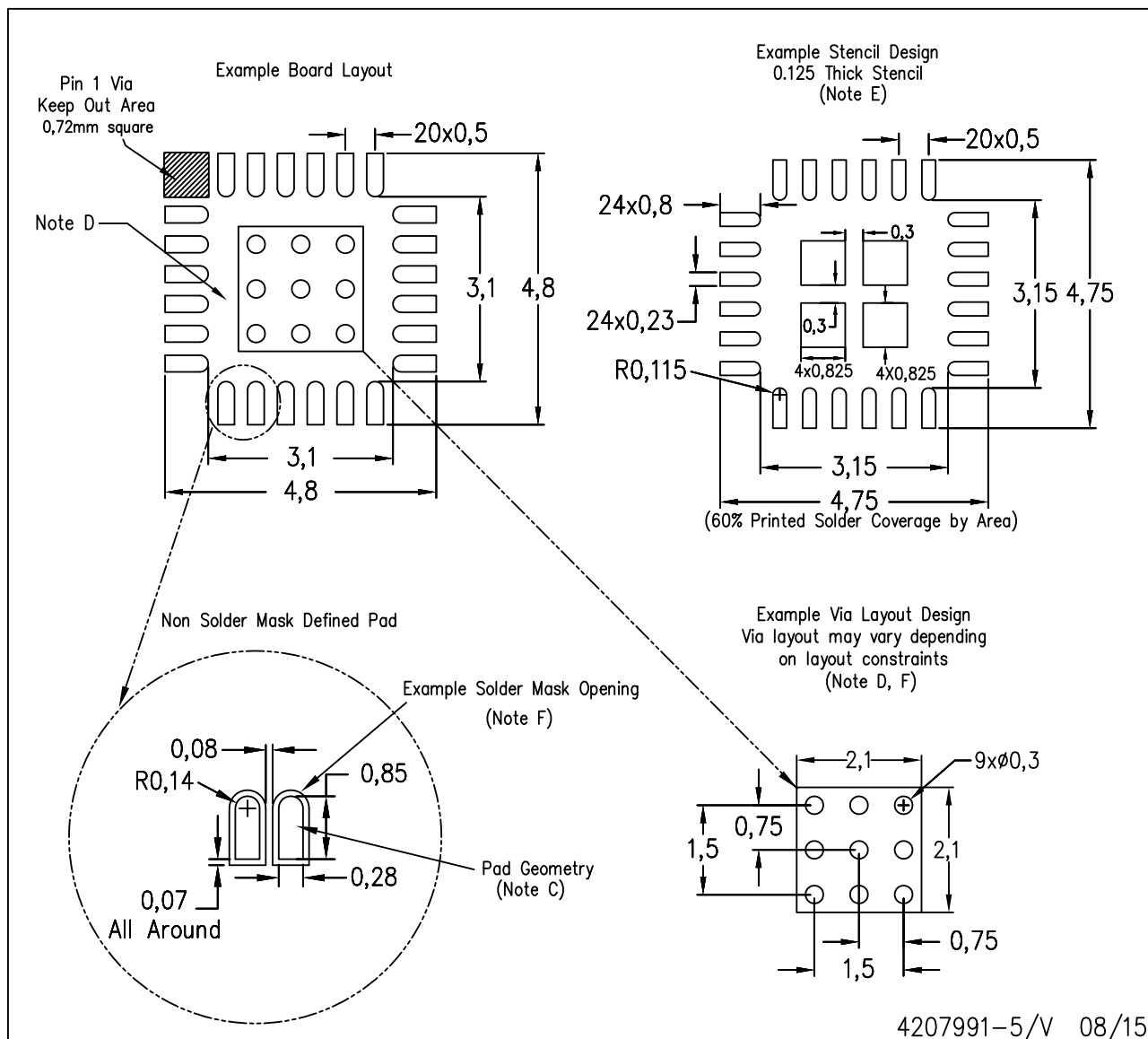

- NOTES:
- All linear dimensions are in millimeters.
 - This drawing is subject to change without notice.
 - Publication IPC-7351 is recommended for alternate designs.
 - This package is designed to be soldered to a thermal pad on the board. Refer to Application Note, Quad Flat-Pack Packages, Texas Instruments Literature No. SLUA271, and also the Product Data Sheets for specific thermal information, via requirements, and recommended board layout. These documents are available at www.ti.com <<http://www.ti.com>>.
 - Laser cutting apertures with trapezoidal walls and also rounding corners will offer better paste release. Customers should contact their board assembly site for stencil design recommendations. Refer to IPC 7525 for stencil design considerations.
 - Customers should contact their board fabrication site for recommended solder mask tolerances and via tenting recommendations for vias placed in the thermal pad.

IMPORTANT NOTICE

Texas Instruments Incorporated and its subsidiaries (TI) reserve the right to make corrections, enhancements, improvements and other changes to its semiconductor products and services per JESD46, latest issue, and to discontinue any product or service per JESD48, latest issue. Buyers should obtain the latest relevant information before placing orders and should verify that such information is current and complete. All semiconductor products (also referred to herein as “components”) are sold subject to TI’s terms and conditions of sale supplied at the time of order acknowledgment.

TI warrants performance of its components to the specifications applicable at the time of sale, in accordance with the warranty in TI’s terms and conditions of sale of semiconductor products. Testing and other quality control techniques are used to the extent TI deems necessary to support this warranty. Except where mandated by applicable law, testing of all parameters of each component is not necessarily performed.

TI assumes no liability for applications assistance or the design of Buyers’ products. Buyers are responsible for their products and applications using TI components. To minimize the risks associated with Buyers’ products and applications, Buyers should provide adequate design and operating safeguards.

TI does not warrant or represent that any license, either express or implied, is granted under any patent right, copyright, mask work right, or other intellectual property right relating to any combination, machine, or process in which TI components or services are used. Information published by TI regarding third-party products or services does not constitute a license to use such products or services or a warranty or endorsement thereof. Use of such information may require a license from a third party under the patents or other intellectual property of the third party, or a license from TI under the patents or other intellectual property of TI.

Reproduction of significant portions of TI information in TI data books or data sheets is permissible only if reproduction is without alteration and is accompanied by all associated warranties, conditions, limitations, and notices. TI is not responsible or liable for such altered documentation. Information of third parties may be subject to additional restrictions.

Resale of TI components or services with statements different from or beyond the parameters stated by TI for that component or service voids all express and any implied warranties for the associated TI component or service and is an unfair and deceptive business practice. TI is not responsible or liable for any such statements.

Buyer acknowledges and agrees that it is solely responsible for compliance with all legal, regulatory and safety-related requirements concerning its products, and any use of TI components in its applications, notwithstanding any applications-related information or support that may be provided by TI. Buyer represents and agrees that it has all the necessary expertise to create and implement safeguards which anticipate dangerous consequences of failures, monitor failures and their consequences, lessen the likelihood of failures that might cause harm and take appropriate remedial actions. Buyer will fully indemnify TI and its representatives against any damages arising out of the use of any TI components in safety-critical applications.

In some cases, TI components may be promoted specifically to facilitate safety-related applications. With such components, TI’s goal is to help enable customers to design and create their own end-product solutions that meet applicable functional safety standards and requirements. Nonetheless, such components are subject to these terms.

No TI components are authorized for use in FDA Class III (or similar life-critical medical equipment) unless authorized officers of the parties have executed a special agreement specifically governing such use.

Only those TI components which TI has specifically designated as military grade or “enhanced plastic” are designed and intended for use in military/aerospace applications or environments. Buyer acknowledges and agrees that any military or aerospace use of TI components which have **not** been so designated is solely at the Buyer’s risk, and that Buyer is solely responsible for compliance with all legal and regulatory requirements in connection with such use.

TI has specifically designated certain components as meeting ISO/TS16949 requirements, mainly for automotive use. In any case of use of non-designated products, TI will not be responsible for any failure to meet ISO/TS16949.

Products

Audio	www.ti.com/audio
Amplifiers	amplifier.ti.com
Data Converters	dataconverter.ti.com
DLP® Products	www.dlp.com
DSP	dsp.ti.com
Clocks and Timers	www.ti.com/clocks
Interface	interface.ti.com
Logic	logic.ti.com
Power Mgmt	power.ti.com
Microcontrollers	microcontroller.ti.com
RFID	www.ti-rfid.com
OMAP Applications Processors	www.ti.com/omap
Wireless Connectivity	www.ti.com/wirelessconnectivity

Applications

Automotive and Transportation	www.ti.com/automotive
Communications and Telecom	www.ti.com/communications
Computers and Peripherals	www.ti.com/computers
Consumer Electronics	www.ti.com/consumer-apps
Energy and Lighting	www.ti.com/energy
Industrial	www.ti.com/industrial
Medical	www.ti.com/medical
Security	www.ti.com/security
Space, Avionics and Defense	www.ti.com/space-avionics-defense
Video and Imaging	www.ti.com/video

TI E2E Community e2e.ti.com