

Excellent Integrated System Limited

Stocking Distributor

Click to view price, real time Inventory, Delivery & Lifecycle Information:

[Diodes Incorporated](#)
[QZX563C6V8C-7](#)

For any questions, you can email us directly:

sales@integrated-circuit.com

QZX563C6V8C
QUAD SURFACE MOUNT TVS ARRAY
Features

- Quad TVS in Common Anode Configuration
- Nominal Zener Voltage: 6.8V
- Ultra-Small Surface Mount Package
- Ideal For Transient Suppression
- **Lead Free By Design/RoHS Compliant (Note 1)**
- **"Green Device" (Note 2)**
- **Qualified to AEC-Q101 Standards for High Reliability**

ESD Capability

- IEC 61000-4-2 Contact Method: $\pm 8\text{kV}$
- IEC 61000-4-2 Air Discharge Method: $\pm 25\text{kV}$

Mechanical Data

- Case: SOT-563
- Case Material: Molded Plastic. UL Flammability Classification Rating 94V-0
- Moisture Sensitivity: Level 1 per J-STD-020D
- Terminal Finish: Matte Tin, Annealed Over Copper Leadframe. Solderable per MIL-STD-202, Method 208
- Orientation: See Diagram
- Marking Information: See Page 3
- Ordering Information: See Page 3
- Weight: 0.003 grams (approximate)



Top View



Bottom View

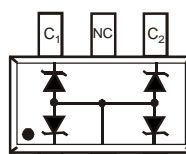

Device Schematic

Maximum Ratings @ $T_A = 25^\circ\text{C}$ unless otherwise specified

Characteristic	Symbol	Value	Unit
Peak Power Dissipation, 10x1000 μs Waveform (Note 5)	P_{pk}	10	W
Peak Power Dissipation, 8x20 μs Waveform (Note 5)		80	
Forward Voltage @ $I_F = 10\text{mA}$ (Note 3)	V_F	0.9	V
Forward Voltage @ $I_F = 100\text{mA}$ (Note 3)	V_F	1.0	V

Thermal Characteristics

Characteristic	Symbol	Value	Unit
Power Dissipation (Note 4)	P_D	150	mW
Thermal Resistance, Junction-to-Ambient (Note 4)	$R_{\theta JA}$	833	$^\circ\text{C}/\text{W}$
Operating and Storage Temperature Range	T_J, T_{STG}	-65 to +150	$^\circ\text{C}$

Electrical Characteristics @ $T_A = 25^\circ\text{C}$ unless otherwise specified

Type Number	Marking Code	Reverse Standoff Voltage and Leakage		Breakdown Voltage (Note 3)			Maximum Reverse Current (Note 3)		Typical Junction Capacitance $C_T @ V_R = 0\text{V}, f = 1\text{MHz}$
		V_{RWM}	$I_R @ V_{RWM}$	$V_{BR} @ I_T = 1\text{mA}$			$I_R @ V_R$		
		V	μA	Min (V)	Nom (V)	Max (V)	μA	V	pF
QZX563C6V8C	CB	5	1.5	6.47	6.8	7.14	1.0	3.0	63

- Notes:
1. No purposefully added lead.
 2. Diodes Inc.'s "Green" policy can be found on our website at http://www.diodes.com/products/lead_free/index.php.
 3. Short duration pulse test used to minimize self-heating effect.
 4. Device mounted on FR-4 PCB, 1 inch x 0.85 inch x 0.062 inch; pad layout as shown on Diodes Inc. Suggested Pad Layout Document AP02001, which can be found on our website at <http://www.diodes.com/datasheets/ap02001.pdf>.
 5. Non-repetitive current pulse per Figure 2 & 3 and derate above $T_A = 25^\circ\text{C}$ per Figure 1.



QZX563C6V8C

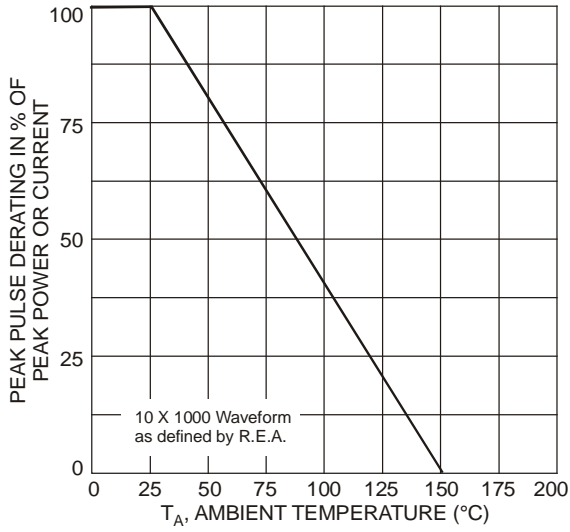

Fig. 1 Pulse Derating Curve

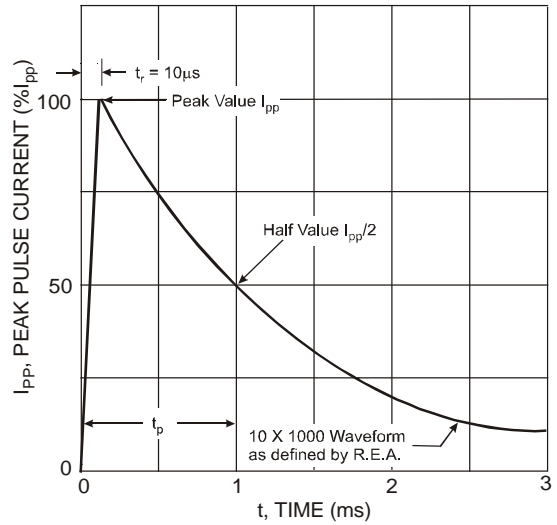

Fig. 2 Pulse Waveform

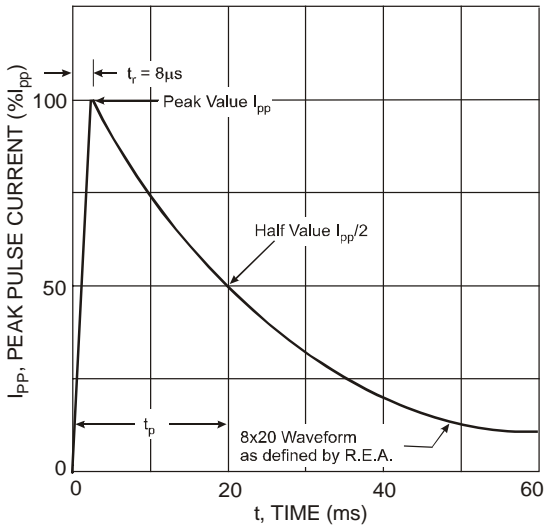

Fig. 3 Pulse Waveform

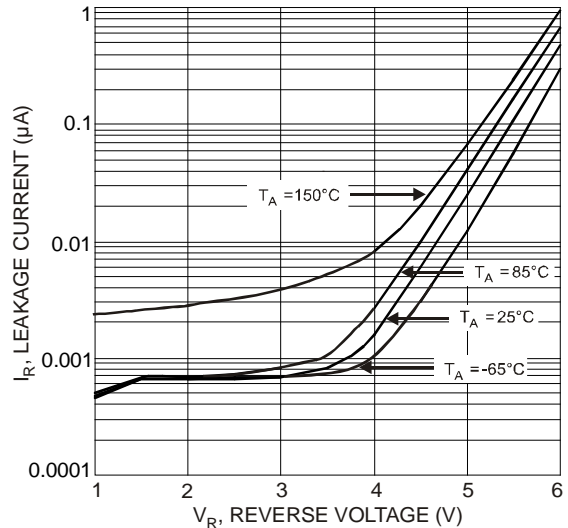

Fig. 4 Typical Leakage Current vs. Reverse Voltage

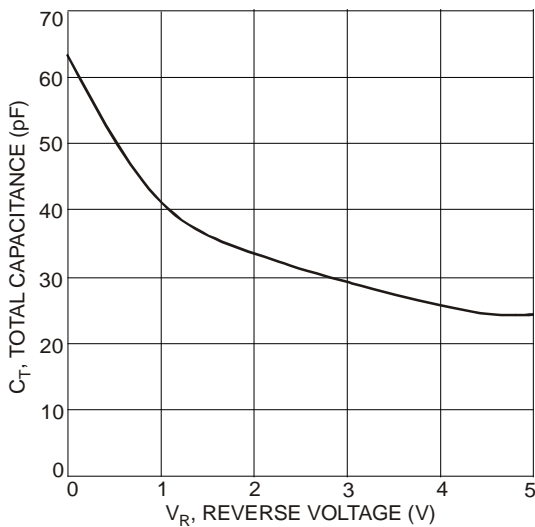

Fig. 5 Typical Total Capacitance vs. Reverse Voltage

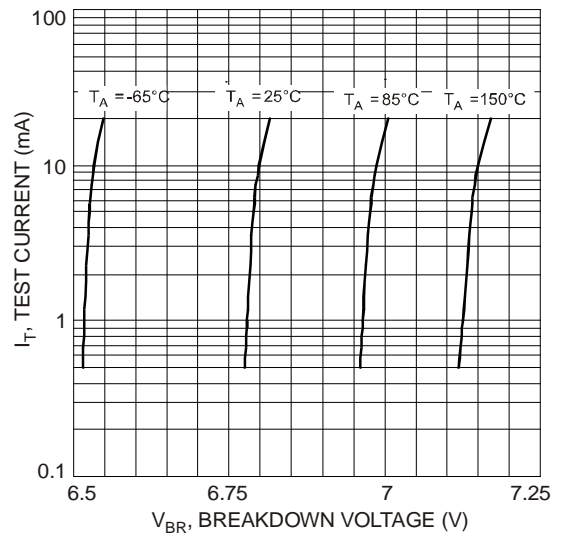

Fig. 6 Breakdown Voltage vs. Test Current



QZX563C6V8C

Ordering Information (Note 6)

Part Number	Case	Packaging
QZX563C6V8C-7	SOT-563	3000/Tape & Reel

Notes: 6. For packaging details, go to our website at <http://www.diodes.com/datasheets/ap02007.pdf>.

Marking Information

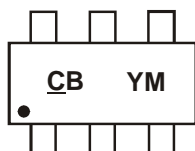

CB = Product Type Marking Code
 YM = Date Code Marking
 Y = Year (Ex: S = 2005)
 M = Month (ex: 9 = September)

Date Code Key

Year	2005	2006	2007	2008	2009	2010	2011	2012	2013	2014	2015
Code	S	T	U	V	W	X	Y	Z	A	B	C

Month	Jan	Feb	Mar	Apr	May	Jun	Jul	Aug	Sep	Oct	Nov	Dec
Code	1	2	3	4	5	6	7	8	9	O	N	D

Package Outline Dimensions

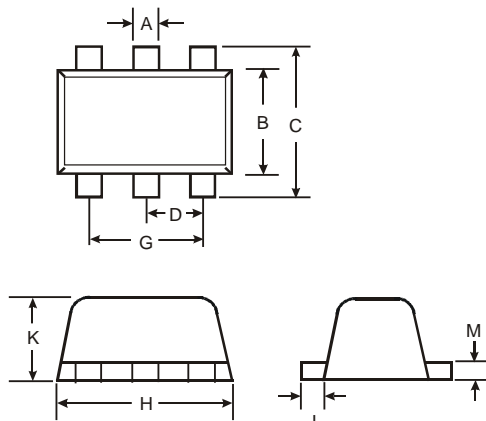

SOT-563			
Dim	Min	Max	Typ
A	0.15	0.30	0.20
B	1.10	1.25	1.20
C	1.55	1.70	1.60
D	-	-	0.50
G	0.90	1.10	1.00
H	1.50	1.70	1.60
K	0.55	0.60	0.60
L	0.10	0.30	0.20
M	0.10	0.18	0.11
All Dimensions in mm			

Suggested Pad Layout

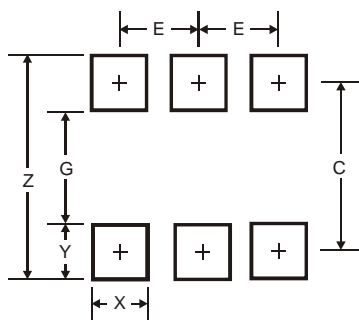

Dimensions	Value (in mm)
Z	2.2
G	1.2
X	0.375
Y	0.5
C	1.7
E	0.5

IMPORTANT NOTICE

Diodes Incorporated and its subsidiaries reserve the right to make modifications, enhancements, improvements, corrections or other changes without further notice to any product herein. Diodes Incorporated does not assume any liability arising out of the application or use of any product described herein; neither does it convey any license under its patent rights, nor the rights of others. The user of products in such applications shall assume all risks of such use and will agree to hold Diodes Incorporated and all the companies whose products are represented on our website, harmless against all damages.

LIFE SUPPORT

Diodes Incorporated products are not authorized for use as critical components in life support devices or systems without the expressed written approval of the President of Diodes Incorporated.