

Excellent Integrated System Limited

Stocking Distributor

Click to view price, real time Inventory, Delivery & Lifecycle Information:

[Fairchild Semiconductor](#)

[FDSS2407](#)

For any questions, you can email us directly:

sales@integrated-circuit.com



December 2004

FDSS2407

N-Channel Dual MOSFET

62V, 3.3A, 132mΩ

Features

- 62V, 132mΩ, 5V Logic Level Gate Dual MOSFET in SO-8
- 5V Logic Level feedback signal of the drain to source voltage. Multiple devices can be wired "OR'd" to a single monitoring circuit input.
- Gate Drive Disable Input. Multiple devices controllable by a single disable transistor.
- Qualified to AEC Q101

Applications

- Automotive Injector Driver
- Solenoid Driver

General Description

This dual N-Channel MOSFET provides added functions as compared to a conventional Power MOSFET. These are: 1. A drain to source voltage feedback signal and 2. A gate drive disable control function that previously required external discrete circuitry. Including these functions within the MOSFET saves printed circuit board space. The drain to source voltage feedback function provides a 5V level output whenever the drain to source voltage is above 62V. This can monitor the time an inductive load takes to dissipate its stored energy. Multiple feedback signals can be wired "OR'd" together to a single input of the monitoring circuit. The gate disable function allows the device to be turned off independent of the drive signal on the gate. This function permits a second control circuit the ability to deactivate the load if necessary. It can also be wired "OR'd" allowing multiple devices to be controlled by a single open collector / drain control transistor.

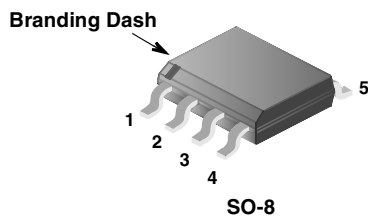

Pin 5 - Drain Feedback Output
 Pin 7 - Gate Drive Disable Input

Internal Diagram

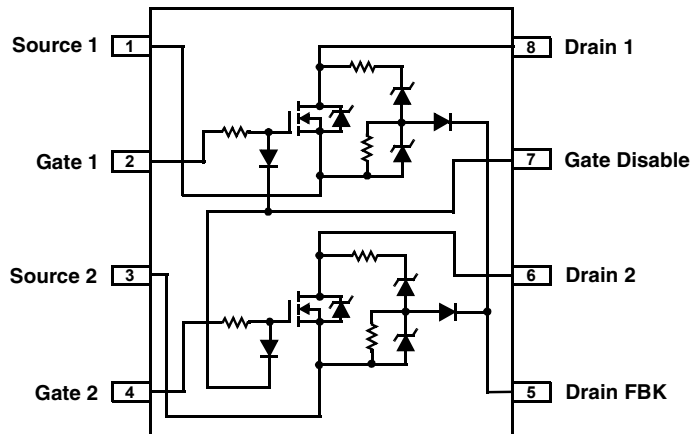

MOSFET Maximum Ratings $T_A=25^{\circ}\text{C}$ unless otherwise noted

Symbol	Parameter	Ratings	Units
V_{DSS}	Drain to Source Voltage	62	V
V_{GS}	Gate to Source Voltage	± 20	V
I_D	Drain Current		
	Continuous ($T_A = 25^{\circ}\text{C}$, $V_{GS} = 10\text{V}$, $R_{\theta JA} = 55^{\circ}\text{C/W}$)	3.3	A
	Continuous ($T_A = 25^{\circ}\text{C}$, $V_{GS} = 5\text{V}$, $R_{\theta JA} = 55^{\circ}\text{C/W}$)	3.0	A
	Pulsed	Figure 4	A
E_{AS}	Single Pulse Avalanche Energy (Note 1)	140	mJ
P_D	Power dissipation	2.27	W
	Derate above 25°C	18	mW/ $^{\circ}\text{C}$
T_J, T_{STG}	Operating and Storage Temperature	-55 to 150	$^{\circ}\text{C}$

Thermal Characteristics

$R_{\theta JA}$	Pad Area = 0.50 in ² (323 mm ²) (Note 2)	55	$^{\circ}\text{C/W}$
$R_{\theta JA}$	Pad Area = 0.027 in ² (17.4 mm ²) (Note 3)	180	$^{\circ}\text{C/W}$
$R_{\theta JA}$	Pad Area = 0.006 in ² (3.87 mm ²) (Note 4)	200	$^{\circ}\text{C/W}$

Package Marking and Ordering Information

Device Marking	Device	Package	Reel Size	Tape Width	Quantity
2407	FDSS2407	SO-8	330 mm	12 mm	2500

Electrical Characteristics $T_A = 25^{\circ}\text{C}$ unless otherwise noted

Symbol	Parameter	Test Conditions	Min	Typ	Max	Units
--------	-----------	-----------------	-----	-----	-----	-------

Off Characteristics

B_{VDSS}	Drain to Source Breakdown Voltage	$I_D = 5\text{mA}$, $V_{GS} = 0\text{V}$	62	-	-	V
I_{DSS}	Zero Gate Voltage Drain Current	$V_{DS} = 15\text{V}$, $V_{GS}=0\text{V}$	-	-	1	μA
		$V_{DS} = 15\text{V}$, $V_{GS}=0\text{V}$, $T_A=150^{\circ}\text{C}$	-	-	250	
I_{GSS}	Gate to Source Leakage Current	$V_{GS} = \pm 20\text{V}$	-	-	± 100	nA

On Characteristics

$V_{GS(TH)}$	Gate to Source Threshold Voltage	$V_{GS} = V_{DS}$, $I_D = 250\mu\text{A}$	1	-	3	V
$r_{DS(ON)}$	Drain to Source On Resistance	$I_D = 3.3\text{A}$, $V_{GS} = 10\text{V}$	-	0.099	0.110	Ω
		$I_D = 3.0\text{A}$, $V_{GS} = 5\text{V}$	-	0.115	0.132	

Dynamic Characteristics

C_{ISS}	Input Capacitance	$V_{DS} = 15\text{V}$, $V_{GS} = 0\text{V}$, $f = 75\text{kHz}$	-	300	-	pF	
C_{OSS}	Output Capacitance		-	140	-	pF	
C_{RSS}	Reverse Transfer Capacitance		-	16	-	pF	
R_G	Gate Resistance		-	8500	-	Ω	
$Q_{g(TOT)}$	Total Gate Charge at 5V	$V_{GS} = 0\text{V}$ to 5V	$V_{DD} = 30\text{V}$ $I_D = 3.3\text{A}$ $I_g = 1.0\text{mA}$	-	3.3	4.3	nC
$Q_{g(TH)}$	Threshold Gate Charge	$V_{GS} = 0\text{V}$ to 1V		-	0.4	0.5	nC
Q_{gs}	Gate to Source Gate Charge			-	1.2	-	nC
Q_{gs2}	Gate Charge Threshold to Plateau			-	0.8	-	nC
Q_{gd}	Gate to Drain "Miller" Charge			-	2.0	-	nC

Switching Characteristics ($V_{GS} = 10V$)

t_{ON}	Turn-On Time	$V_{DD} = 30V, I_D = 3.3A$ $V_{GS} = 10V, R_{GS} = 47\Omega$	-	-	2700	ns
$t_{d(ON)}$	Turn-On Delay Time		-	630	-	ns
t_r	Rise Time		-	1200	-	ns
$t_{d(OFF)}$	Turn-Off Delay Time		-	8700	-	ns
t_f	Fall Time		-	3500	-	ns
t_{OFF}	Turn-Off Time		-	-	18500	ns

Drain-Source Diode Characteristics

V_{SD}	Source to Drain Diode Voltage	$I_{SD} = 3.3A$	-	-	1.25	V
		$I_{SD} = 1.7A$	-	-	1.0	V
t_{rr}	Reverse Recovery Time	$I_{SD} = 3.3A, dI_{SD}/dt = 100A/\mu s$	-	-	45	ns
Q_{RR}	Reverse Recovered Charge	$I_{SD} = 3.3A, dI_{SD}/dt = 100A/\mu s$	-	-	60	nC

Drain Feedback Characteristics

$V_{FBK(Low)}$	Feedback to Source Voltage	$V_{DS} = 35V, R_{FBK-SOURCE} = 51K\Omega$	-	1	1.5	V
$V_{FBK(High)}$	Feedback to Source Voltage	$V_{DS} = 62V, R_{FBK-SOURCE} = 51K\Omega$	3.5	4.4	-	V

Gate Drive Disable Characteristics

$V_{DIS(High)}$	Gate Drive Disable Input Voltage, Gate Enabled	$V_{GS} = 5V, I_D = 3.0A, T_J = 25^\circ C$	3	-	-	V
$V_{DIS(Low)}$	Gate Drive Disable Input Voltage, Gate Disabled	$V_{GS} = V_{DS} = 10V, I_D \leq 250\mu A, T_J = 150^\circ C$	-	-	0.4	V

Notes:

- Starting $T_J = 25^\circ C, L = 42mH, I_{AS} = 2.6A, V_{DD} = 62V, V_{GS} = 10V$.
- 55°C/W measured using FR-4 board with 0.50 in² (323 mm²) copper pad at 1 second.
- 180°C/W measured using FR-4 board with 0.027 in² (17.4 mm²) copper pad at 1000 seconds.
- 200°C/W measured using FR-4 board with 0.006 in² (3.87 mm²) copper pad at 1000 seconds.

This product has been designed to meet the extreme test conditions and environment demanded by the automotive industry. For a copy of the requirements, see AEC Q101 at: <http://www.aecouncil.com/>
 All Fairchild Semiconductor products are manufactured, assembled and tested under ISO9000 and QS9000 quality systems certification.

Typical Characteristics $T_A = 25^\circ\text{C}$ unless otherwise noted

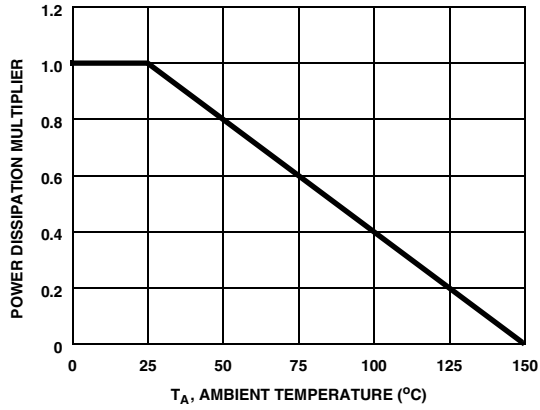

Figure 1. Normalized Power Dissipation vs Ambient Temperature

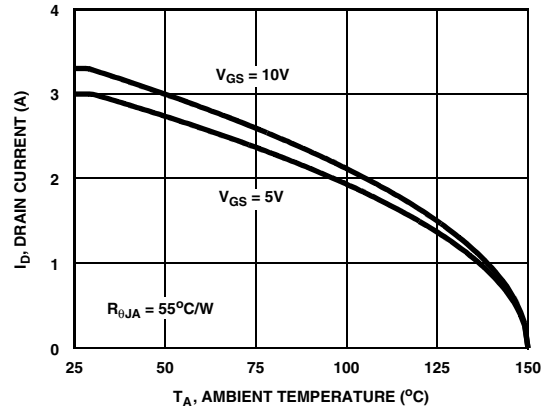

Figure 2. Maximum Continuous Drain Current vs Ambient Temperature

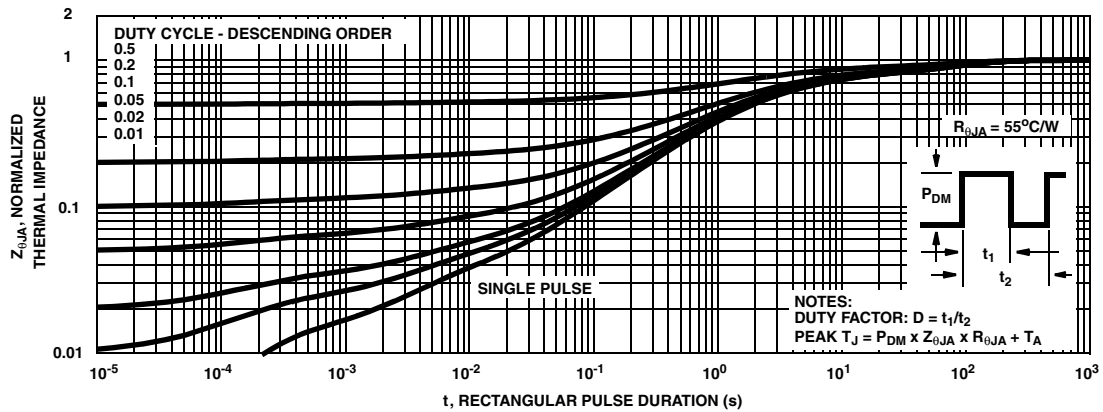

Figure 3. Normalized Maximum Transient Thermal Impedance

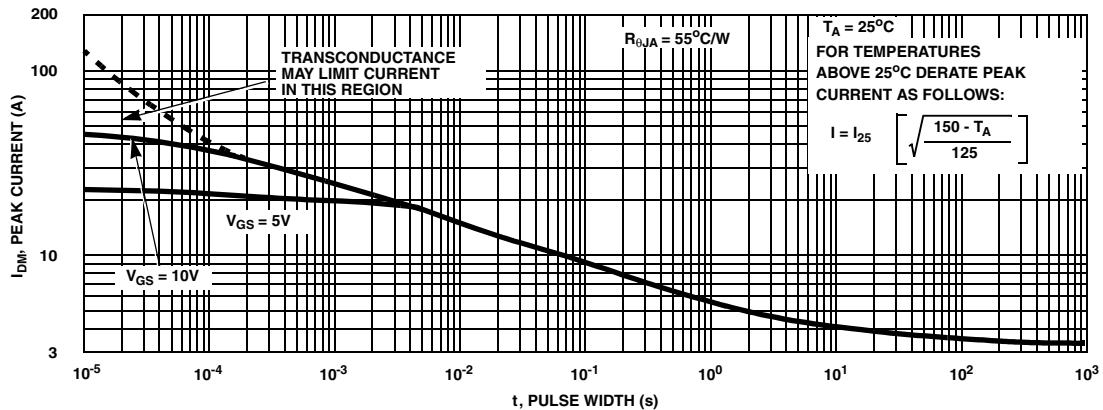

Figure 4. Peak Current Capability

Typical Characteristics (Continued) $T_A = 25^\circ\text{C}$ unless otherwise noted

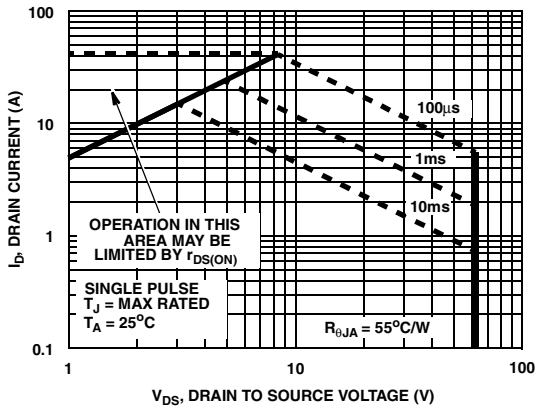
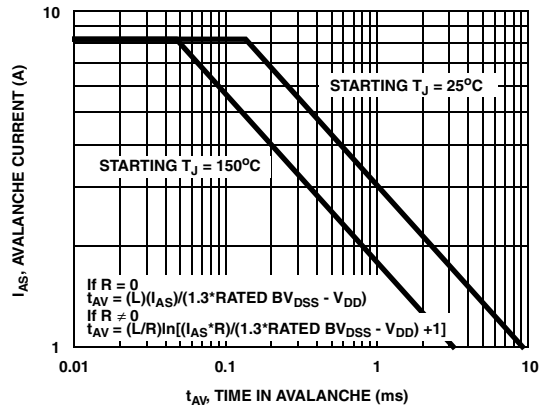

Figure 5. Forward Bias Safe Operating Area



NOTE: Refer to Fairchild Application Notes AN7514 and AN7515
Figure 6. Unclamped Inductive Switching Capability

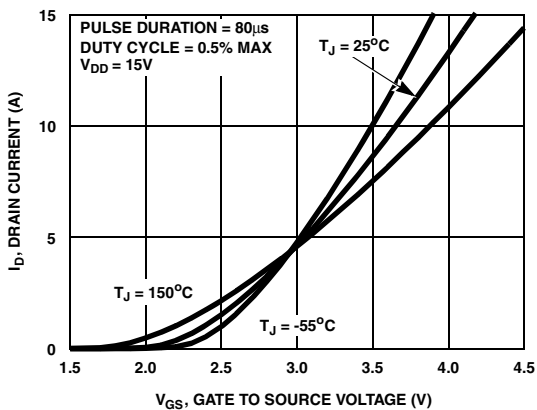

Figure 7. Transfer Characteristics

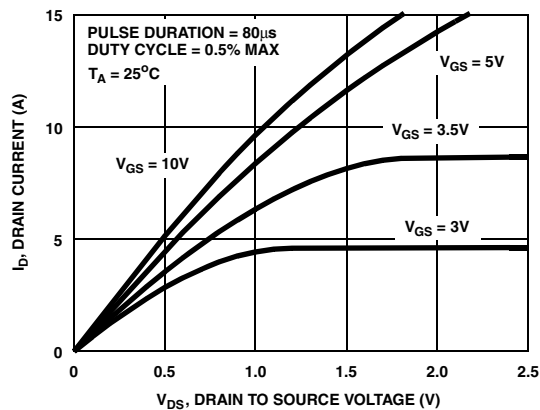

Figure 8. Saturation Characteristics

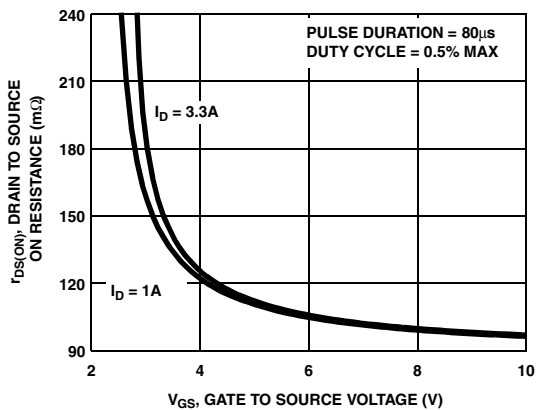

Figure 9. Drain to Source On Resistance vs Gate Voltage and Drain Current

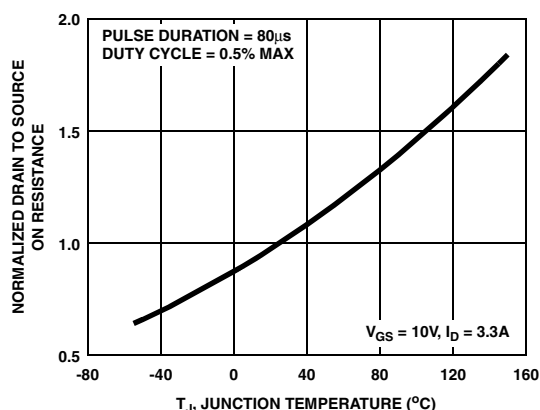

Figure 10. Normalized Drain to Source On Resistance vs Junction Temperature

Typical Characteristics (Continued) $T_A = 25^\circ\text{C}$ unless otherwise noted

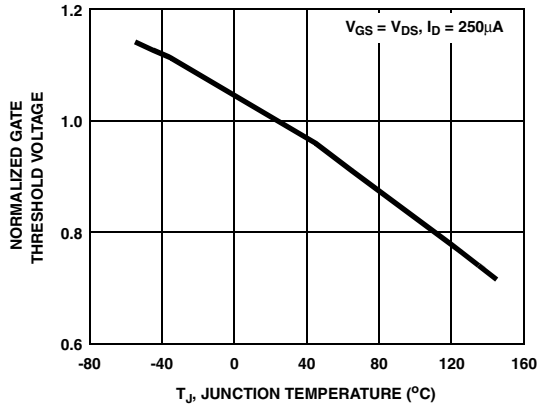

Figure 11. Normalized Gate Threshold Voltage vs Junction Temperature

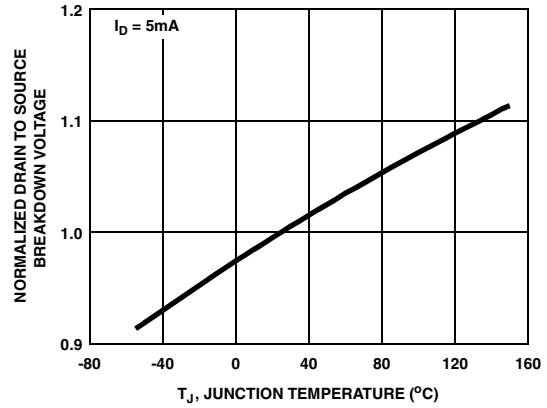

Figure 12. Normalized Drain to Source Breakdown Voltage vs Junction Temperature

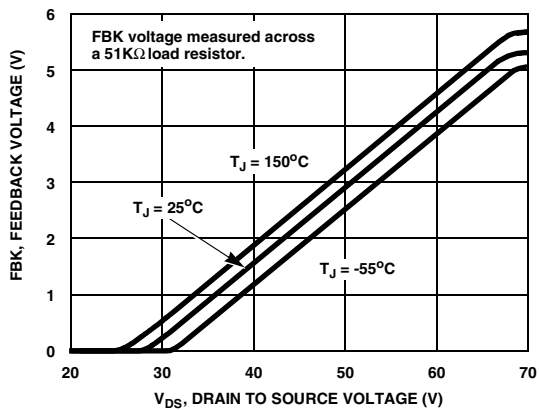

Figure 13. Feedback Voltage vs Drain to Source Voltage

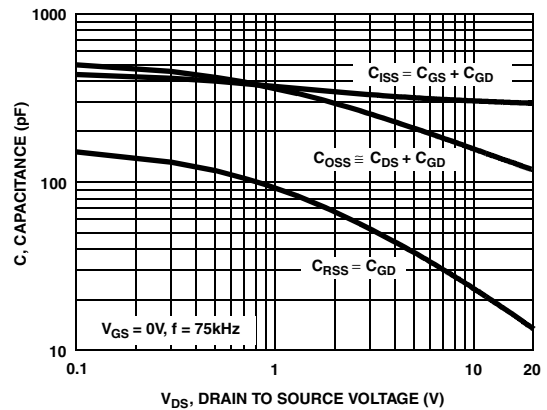

Figure 14. Capacitance vs Drain to Source Voltage

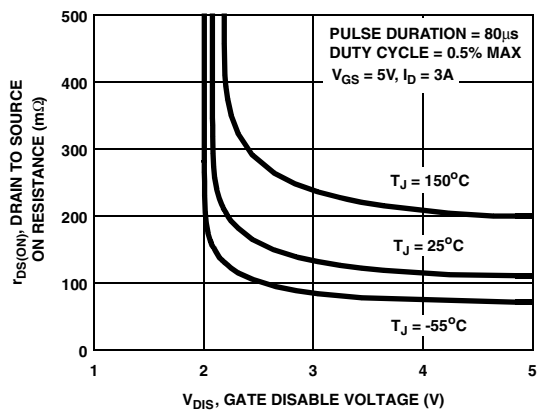

Figure 15. Drain to Source On Resistance vs Gate Disable Voltage

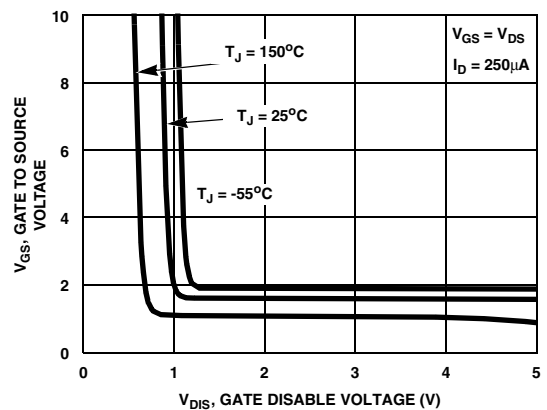

Figure 16. Gate to Source Voltage vs Gate Disable Voltage

Typical Characteristics (Continued) $T_A = 25^\circ\text{C}$ unless otherwise noted

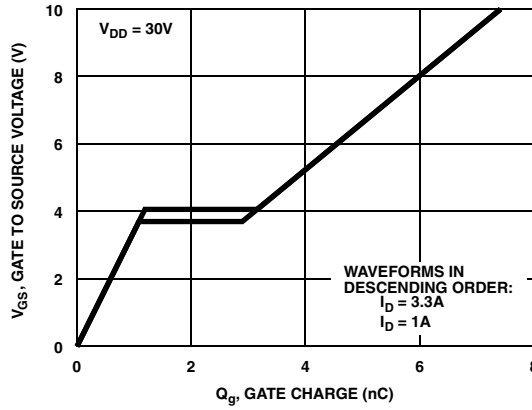

Figure 17. Gate Charge Waveforms for Constant Gate Currents

Test Circuits and Waveforms

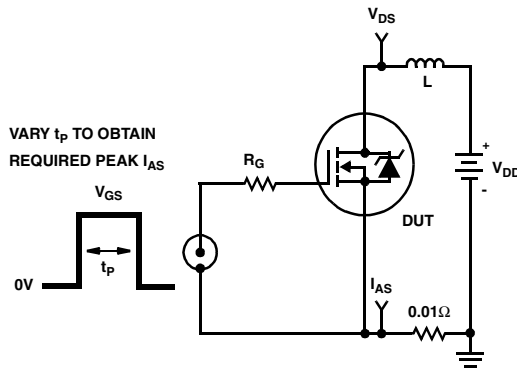

Figure 18. Unclamped Energy Test Circuit

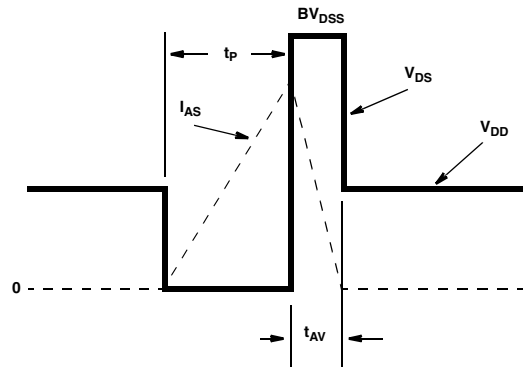

Figure 19. Unclamped Energy Waveforms

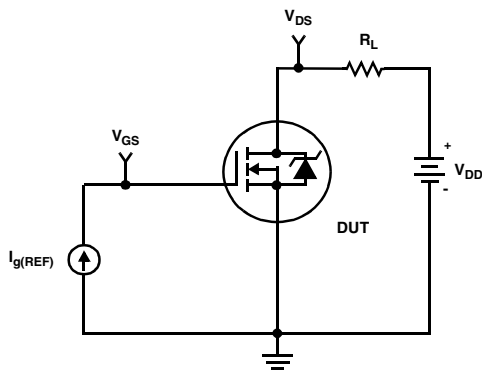

Figure 20. Gate Charge Test Circuit

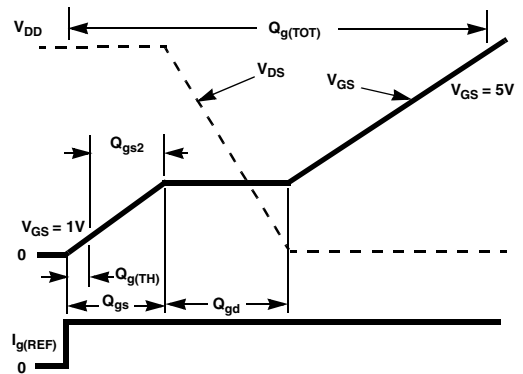

Figure 21. Gate Charge Waveforms

Test Circuits and Waveforms (Continued)

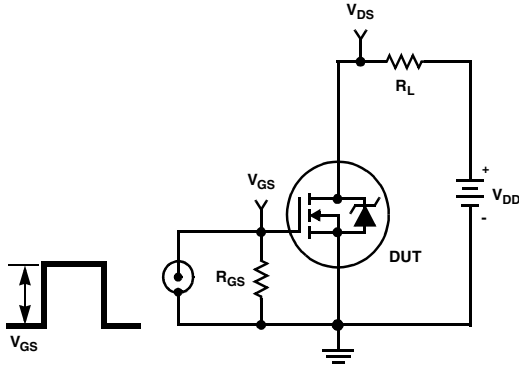

Figure 22. Switching Time Test Circuit

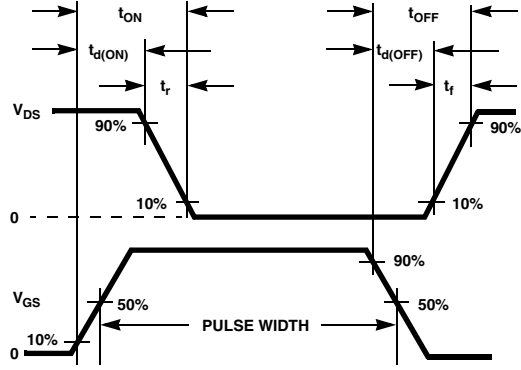

Figure 23. Switching Time Waveforms

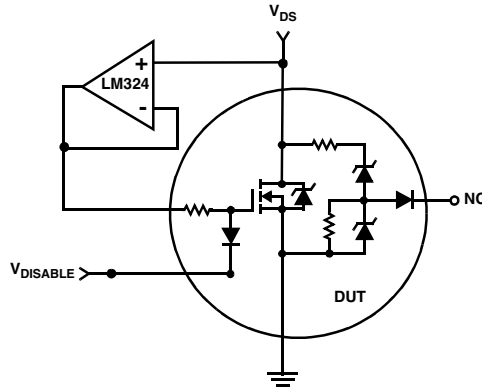

Figure 24. Gate to Source Voltage vs Gate Disable Voltage

Thermal Resistance vs. Mounting Pad Area

The maximum rated junction temperature, T_{JM} , and the thermal resistance of the heat dissipating path determines the maximum allowable device power dissipation, P_{DM} , in an application. Therefore the application's ambient temperature, T_A ($^{\circ}C$), and thermal resistance $R_{\theta JA}$ ($^{\circ}C/W$) must be reviewed to ensure that T_{JM} is never exceeded. Equation 1 mathematically represents the relationship and serves as the basis for establishing the rating of the part.

$$P_{DM} = \frac{(T_{JM} - T_A)}{R_{\theta JA}} \quad (EQ. 1)$$

In using surface mount devices such as the SO8 package, the environment in which it is applied will have a significant influence on the part's current and maximum power dissipation ratings. Precise determination of P_{DM} is complex and influenced by many factors:

1. Mounting pad area onto which the device is attached and whether there is copper on one side or both sides of the board.
2. The number of copper layers and the thickness of the board.
3. The use of external heat sinks.
4. The use of thermal vias.
5. Air flow and board orientation.
6. For non steady state applications, the pulse width, the duty cycle and the transient thermal response of the part, the board and the environment they are in.

Fairchild provides thermal information to assist the designer's preliminary application evaluation. Figure 25 defines the $R_{\theta JA}$ for the device as a function of the top copper (component side) area. This is for a horizontally positioned FR-4 board with 1oz copper after 1000 seconds of steady state power with no air flow. This graph provides the necessary information for calculation of the steady state junction temperature or power dissipation. Pulse applications can be evaluated using the Fairchild device Spice thermal model or manually utilizing the normalized

maximum transient thermal impedance curve.

Thermal resistances corresponding to other copper areas can be obtained from Figure 25 or by calculation using Equation 2. The area, in square inches is the top copper area including the gate and source pads.

$$R_{\theta JA} = 79.9 + \frac{15}{0.14 + Area} \quad (EQ. 2)$$

The transient thermal impedance ($Z_{\theta JA}$) is also effected by varied top copper board area. Figure 26 shows the effect of copper pad area on single pulse transient thermal impedance. Each trace represents a copper pad area in square inches corresponding to the descending list in the graph. Spice and SABER thermal models are provided for each of the listed pad areas.

Copper pad area has no perceivable effect on transient thermal impedance for pulse widths less than 100ms. For pulse widths less than 100ms the transient thermal impedance is determined by the die and package. Therefore, C THERM1 through C THERM5 and R THERM1 through R THERM5 remain constant for each of the thermal models. A listing of the model component values is available in Table 1.

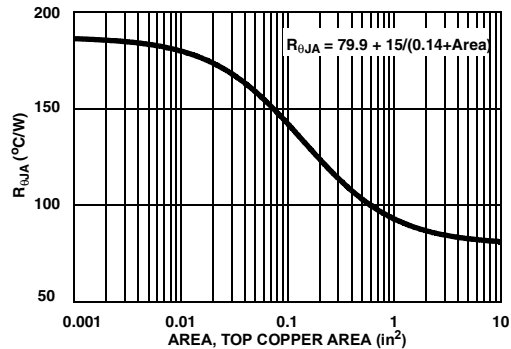

Figure 25. Thermal Resistance vs Mounting Pad Area

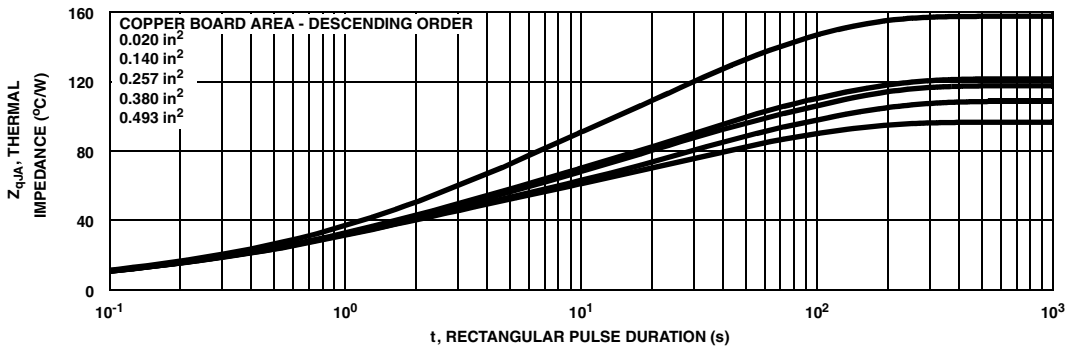

Figure 26. Thermal Impedance vs Mounting Pad Area

PSPICE Electrical Model

.SUBCKT FDSS2407 2 1 3 101 102 ; rev July 2004

```

Ca 12 8 1e-10
Cb 15 14 4e-10
Cin 6 8 2.8e-10
Dbody 7 5 DbodyMOD
Dbreak 5 11 DbreakMOD
Dplcap 10 5 DplcapMOD
CGATE 9 20 5e-9
DDISABLE 20 101 DDISABLEMOD
DFBK1 104 103 DFBK1MOD
DFBK2 7 104 DFBK2MOD
DFBK3 104 102 DFBK3MOD
RFBK1 5 103 RFBK1MOD 13e3
RFBK2 104 7 RFBK2MOD 2.15e3
Ebreak 11 7 17 18 67.4
Eds 14 8 5 8 1
Egs 13 8 6 8 1
Esg 6 10 6 8 1
EVthres 6 21 19 8 1
Evttemp 20 6 18 22 1
It 8 17 1
Lgate 1 9 1.8e-9
Ldrain 2 5 1.0e-9
Lsource 3 7 0.6e-9
RLgate 1 9 18
RLdrain 2 5 10
RLsource 3 7 6
Mmed 16 6 8 8 MmedMOD
Mstro 16 6 8 8 MstroMOD
Mweak 16 21 8 8 MweakMOD
Rbreak 17 18 RbreakMOD 1
Rdrain 50 16 RdrainMOD 3.5e-2
Rgate 9 20 RgateMOD 8.63e3
RSLC1 5 51 RSLCMOD 1e-6
RSLC2 5 50 1e3
Rsource 8 7 RsourceMOD 5.3e-2
RVthres 22 8 RVthresMOD 1
RVtemp 18 19 RVtempMOD 1
S1a 6 12 13 8 S1AMOD
S1b 13 12 13 8 S1BMOD
S2a 6 15 14 13 S2AMOD
S2b 13 15 14 13 S2BMOD
Vbat 22 19 DC 1
ESLC 51 50 VALUE=((V(5,51)/ABS(V(5,51)))*(PWR(V(5,51))/(1e-6*20),3.5))
.DMODEL DbodyMOD D (IS=1.1E-12 N=1.05 IKF=4e-1 RS=4.2e-2 TRS1=3e-4 TRS2=1.3e-6
+ CJO=3.3e-10 TT=3e-8 M=0.38, XTI=3.5)
.DMODEL DbreakMOD D (RS=1 TRS1=1e-3 TRS2=-9e-6)
.DMODEL DplcapMOD D (CJO=1.97e-10 IS=1e-30 N=10 M=0.84)
.DMODEL DDISABLEMOD D (RS=30 IS=1e-15 BV=4.7 TBV1=-3e-4 TBV2=-3e-6 XTI=0)
.DMODEL DFBK1MOD D (IS=1e-15 BV=23.8 IKF=2 TBV1=-6e-4 TBV2=6e-6)
.DMODEL DFBK2MOD D (RS=1 IS=1e-30 BV=5.6 N=3.3 NBV=1)
.DMODEL DFBK3MOD D (RS=1 IS=1e-15 BV=4.2 NBV=2.5)
.DMODEL MmedMOD NMOS (VTO=1.7 KP=1.08 IS=1e-30 N=10 TOX=1 L=1u W=1u RG= 8.56e3)
.DMODEL MstroMOD NMOS (VTO=2 KP=14 IS=1e-30 N=10 TOX=1 L=1u W=1u)
.DMODEL MweakMOD NMOS (VTO=1.5 kp=0.04 IS=1e-30 N=10 TOX=1 L=1u W=1u RG= 8.56e4 RS=0.1)
.DMODEL RbreakMOD RES (TC1=1.05e-3 TC2=-9e-7)
.DMODEL RdrainMOD RES (TC1=9e-3 TC2=2.7e-5)
.DMODEL RSLCMOD RES (TC1=2e-3 TC2=6e-6)
.DMODEL RsourceMOD RES (TC1=3e-3 TC2=1e-6)
.DMODEL RVthresMOD RES (TC1=-1.1e-3 TC2=-3.3e-6)
.DMODEL RVtempMOD RES (TC1=-1.6e-3 TC2=1e-7)
.DMODEL RFBK1MOD RES (TC1=-1.4e-3 TC2=1e-6)
.DMODEL RFBK2MOD RES (TC1=-1.4e-3 TC2=1e-6)
.DMODEL RgateMOD RES (TC1=-1.4e-3 TC2=1e-5)
.DMODEL S1AMOD VSWITCH (RON=1e-5 ROFF=0.1 VON=-4.0 VOFF=-3.0)
.DMODEL S1BMOD VSWITCH (RON=1e-5 ROFF=0.1 VON=-3.0 VOFF=-4.0)
.DMODEL S2AMOD VSWITCH (RON=1e-5 ROFF=0.1 VON=-1.0 VOFF=-0.5)
.DMODEL S2BMOD VSWITCH (RON=1e-5 ROFF=0.1 VON=-0.5 VOFF=-1.0)
.ENDS

```

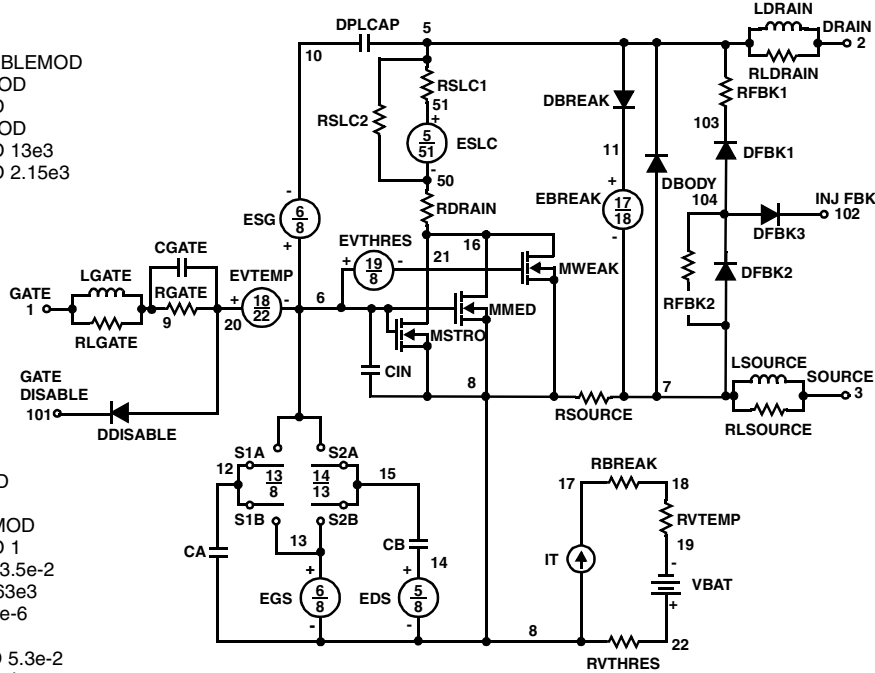

Note: For further discussion of the PSPICE model, consult **A New PSPICE Sub-Circuit for the Power MOSFET Featuring Global Temperature Options**; IEEE Power Electronics Specialist Conference Records, 1991, written by William J. Hepp and C. Frank Wheatley.

SABER Electrical Model

REV July 2004

template FDSS2407 n2,n1,n3,n101,n102

electrical n2,n1,n3,n101,n102

```
{
var i iscl
dp..model dbodymod = (isl=1.1e-12,nl=1.05,ikf=4e-1,rs=4.2e-2,trs1=3e-4,trs2=1.3e-6,cjo=3.3e-10,tt=3e-8,m=0.38,xti=3.5)
dp..model dbreakmod = (rs=1,trs1=1e-3,trs2=-9e-6)
dp..model ddisablemod = (rs=30,isl=1e-15,bv=4.7,tbv1=-3e-4,tbv2=-3e-6,xti=0)
dp..model dfbk1mod = (isl=1e-15,bv=23.8,ikf=2,tbv1=-6e-4,tbv2=6e-6)
dp..model dfbk2mod = (rs=1,isl=1e-30,bv=5.6,nl=3.3,nbv=1)
dp..model dfbk3mod = (rs=1,isl=1e-15,bv=4.2,nbv=2.5)
dp..model dplcapmod = (cjo=1.97e-10,isl=10e-30,nl=10,m=0.84)
```

```
m..model mmedmod = (type=_n,vto=1.7,kp=1.08,is=1e-30,tox=1)
m..model mstrongmod = (type=_n,vto=2,kp=14,is=1e-30,tox=1)
m..model mweakmod = (type=_n,vto=1.5,kp=0.04,is=1e-30,tox=1,rs=0.1)
m.mmed n16 n6 n8 n8 = model=mmedmod, l=1u, w=1u
m.mstrong n16 n6 n8 n8 = model=mstrongmod, l=1u, w=1u
m.mweak n16 n21 n8 n8 = model=mweakmod, l=1u, w=1u
```

```
sw_vcsp..model s1amod = (ron=1e-5,roff=0.1,von=-4.0,voff=-3.0)
sw_vcsp..model s1bmod = (ron=1e-5,roff=0.1,von=-3.0,voff=-4.0)
sw_vcsp..model s2amod = (ron=1e-5,roff=0.1,von=-1.0,voff=-0.5)
sw_vcsp..model s2bmod = (ron=1e-5,roff=0.1,von=-0.5,voff=-1.0)
```

```
c.ca n12 n8 = 1e-10
c.cb n15 n14 = 4e-10
c.cin n6 n8 = 2.8e-10
c.cgate n9 n20 = 5e-9
```

```
dp.dbody n7 n5 = model=dbodymod
dp.dbreak n5 n11 = model=dbreakmod
dp.dplcap n10 n5 = model=dplcapmod
dp.ddisable n20 n101 = model=ddisablemod
dp.dfbk1 n104 n103 = model=dfbk1mod
dp.dfbk2 n7 n104 = model=dfbk2mod
dp.dfbk3 n104 n102 = model=dfbk3mod
spe.ebreak n11 n7 n17 n18 = 67.4
spe.eds n14 n8 n5 n8 = 1
spe.egs n13 n8 n6 n8 = 1
spe.esg n6 n10 n6 n8 = 1
spe.evthres n6 n21 n19 n8 = 1
spe.evtemp n20 n6 n18 n22 = 1
```

```
i.it n8 n17 = 1
l.lgate n1 n9 = 1.8e-9
l.ldrain n2 n5 = 1.0e-9
l.lsource n3 n7 = 0.6e-9
res.rlgate n1 n9 = 18
res.rldrain n2 n5 = 10
res.rlsource n3 n7 = 6
res.rbreak n17 n18 = 1, tc1=1.05e-3,tc2=-9e-7
res.rdrain n5 n16 = 3.5e-2,tc1=9e-3,tc2=2.7e-5
res.rgate n9 n20 = 8.63e3,tc1=-1.4e-3,tc2=1e-5
res.rfbk1 n5 n103 = 13e3,tc1=-1.4e-3,tc2=1e-6
res.rfbk2 n104 n7 = 2.15e3,tc1=-1.4e-3,tc2=1e-6
res.rslc1 n5 n51 = 1e-6,tc1=2e-3,tc2=6e-6
res.rslc2 n5 n50 = 1e3
res.rsource n8 n7 = 5.3e-2,tc1=3e-3,tc2=1e-6
res.rvthres n22 n8 = 1,tc1=-1.1e-3,tc2=-3.3e-6
res.rvtemp n18 n19 = 1,tc1=-1.6e-3,tc2=1e-7
```

```
sw_vcsp.s1a n6 n12 n13 n8 = model=s1amod
sw_vcsp.s1b n13 n12 n13 n8 = model=s1bmod
sw_vcsp.s2a n6 n15 n14 n13 = model=s2amod
sw_vcsp.s2b n13 n15 n14 n13 = model=s2bmod
v.vbat n22 n19 = dc=1
equations {
i (n51->n50) +=iscl
iscl: v(n51,n50) = ((v(n5,n51)/(1e-9+abs(v(n5,n51))))*(abs(v(n5,n51))*1e6/20))** 3.5)
}
}
```

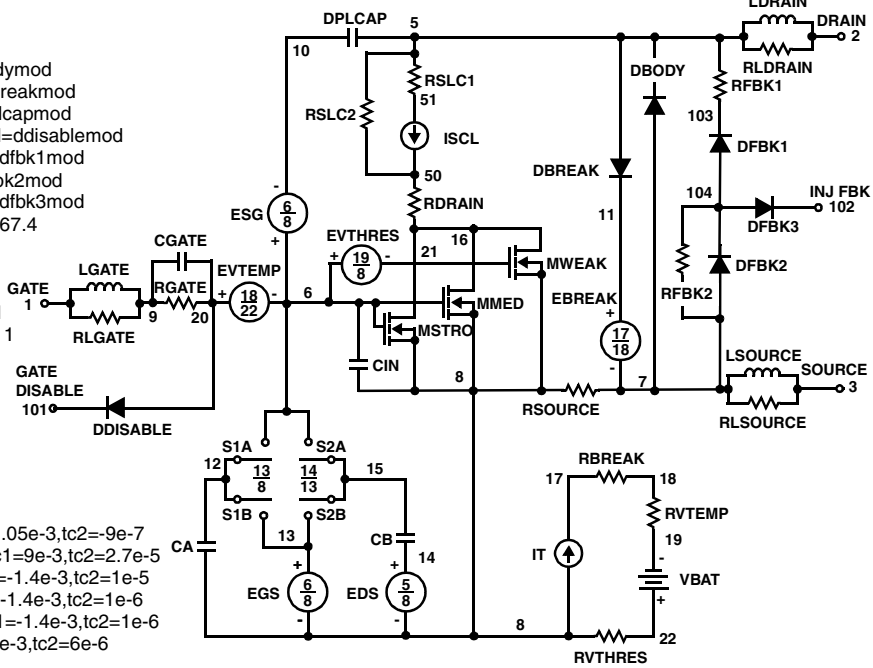

SPICE Thermal Model

REV July 2004
FDSS2407T
Copper Area =0.5 in²

CTHERM1 Junction c2 1.2e-4
CTHERM2 c2 c3 2e-3
CTHERM3 c3 c4 2e-2
CTHERM4 c4 c5 3.0e-2
CTHERM5 c5 c6 4e-2
CTHERM6 c6 c7 7e-2
CTHERM7 c7 c8 2e-1
CTHERM8 c8 Ambient 2.8

RTHERM1 Junction c2 1.4
RTHERM2 c2 c3 2.0
RTHERM3 c3 c4 2.8
RTHERM4 c4 c5 9.0
RTHERM5 c5 c6 18.0
RTHERM6 c6 c7 26.0
RTHERM7 c7 c8 28.0
RTHERM8 c8 Ambient 29.0

SABER Thermal Model

Copper Area = 0.5 in²
template thermal_model th tl
thermal_c th, tl
{
ctherm.ctherm1 th c2 =1.2e-4
ctherm.ctherm2 c2 c3 =2e-3
ctherm.ctherm3 c3 c4 =2e-2
ctherm.ctherm4 c4 c5 =3.0e-2
ctherm.ctherm5 c5 c6 =4e-2
ctherm.ctherm6 c6 c7 =7e-2
ctherm.ctherm7 c7 c8 =2e-1
ctherm.ctherm8 c8 tl =2.8

rtherm.rtherm1 th c2 =1.4
rtherm.rtherm2 c2 c3 =2.0
rtherm.rtherm3 c3 c4 =2.8
rtherm.rtherm4 c4 c5 =9.0
rtherm.rtherm5 c5 c6 =18.0
rtherm.rtherm6 c6 c7 =26.0
rtherm.rtherm7 c7 c8 =28.0
rtherm.rtherm8 c8 tl =29.0
}

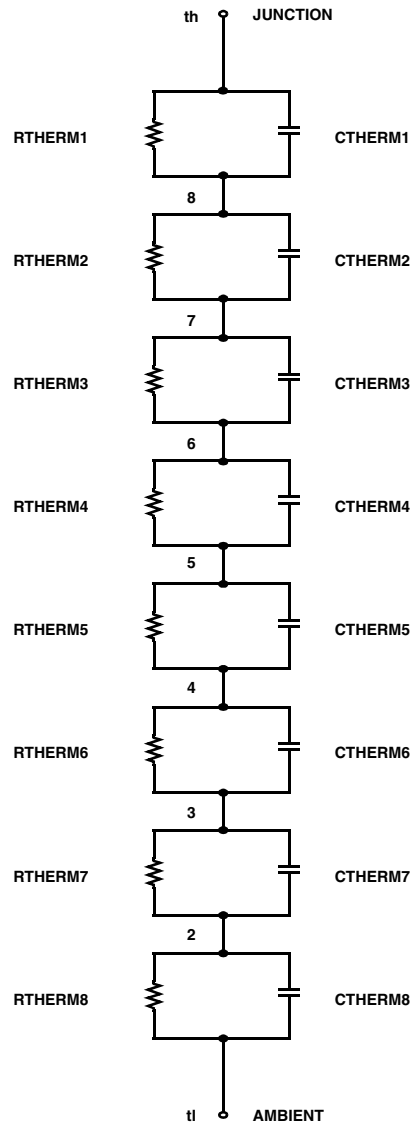

TRADEMARKS

The following are registered and unregistered trademarks Fairchild Semiconductor owns or is authorized to use and is not intended to be an exhaustive list of all such trademarks.

ACEx™	FACT Quiet Series™	ImpliedDisconnect™	POP™	Stealth™
ActiveArray™	FAST®	IntelliMAX™	Power247™	SuperFET™
Bottomless™	FASTr™	ISOPLANAR™	PowerEdge™	SuperSOT™-3
CoolFET™	FPS™	LittleFET™	PowerSaver™	SuperSOT™-6
CROSSVOLT™	FRFET™	MICROCOUPLER™	PowerTrench®	SuperSOT™-8
DOMET™	GlobalOptoisolator™	MicroFET™	QFET®	SyncFET™
EcoSPARK™	GTO™	MicroPak™	QS™	TinyLogic®
E ² CMOS™	HiSeC™	MICROWIRE™	QT Optoelectronics™	TINYOPTO™
EnSigna™	i ² C™	MSX™	Quiet Series™	TruTranslation™
FACT™	i-Lo™	MSXPro™	RapidConfigure™	UHC™
		OCX™	RapidConnect™	UltraFET®
Across the board. Around the world.™		OCXPro™	µSerDes™	UniFET™
The Power Franchise®		OPTOLOGIC®	SILENT SWITCHER®	VCX™
Programmable Active Droop™		OPTOPLANAR™	SMART START™	
		PACMAN™	SPM™	

DISCLAIMER

FAIRCHILD SEMICONDUCTOR RESERVES THE RIGHT TO MAKE CHANGES WITHOUT FURTHER NOTICE TO ANY PRODUCTS HEREIN TO IMPROVE RELIABILITY, FUNCTION OR DESIGN. FAIRCHILD DOES NOT ASSUME ANY LIABILITY ARISING OUT OF THE APPLICATION OR USE OF ANY PRODUCT OR CIRCUIT DESCRIBED HEREIN; NEITHER DOES IT CONVEY ANY LICENSE UNDER ITS PATENT RIGHTS, NOR THE RIGHTS OF OTHERS.

LIFE SUPPORT POLICY

FAIRCHILD'S PRODUCTS ARE NOT AUTHORIZED FOR USE AS CRITICAL COMPONENTS IN LIFE SUPPORT DEVICES OR SYSTEMS WITHOUT THE EXPRESS WRITTEN APPROVAL OF FAIRCHILD SEMICONDUCTOR CORPORATION.

As used herein:

- Life support devices or systems are devices or systems which, (a) are intended for surgical implant into the body, or (b) support or sustain life, or (c) whose failure to perform when properly used in accordance with instructions for use provided in the labeling, can be reasonably expected to result in significant injury to the user.
- A critical component is any component of a life support device or system whose failure to perform can be reasonably expected to cause the failure of the life support device or system, or to affect its safety or effectiveness.

PRODUCT STATUS DEFINITIONS

Definition of Terms

Datasheet Identification	Product Status	Definition
Advance Information	Formative or In Design	This datasheet contains the design specifications for product development. Specifications may change in any manner without notice.
Preliminary	First Production	This datasheet contains preliminary data, and supplementary data will be published at a later date. Fairchild Semiconductor reserves the right to make changes at any time without notice in order to improve design.
No Identification Needed	Full Production	This datasheet contains final specifications. Fairchild Semiconductor reserves the right to make changes at any time without notice in order to improve design.
Obsolete	Not In Production	This datasheet contains specifications on a product that has been discontinued by Fairchild semiconductor. The datasheet is printed for reference information only.

Rev. I15