

Excellent Integrated System Limited

Stocking Distributor

Click to view price, real time Inventory, Delivery & Lifecycle Information:

[IXYS Corporation](#)
[DHG30I1200HA](#)

For any questions, you can email us directly:
sales@integrated-circuit.com

Sonic Fast Recovery Diode

High Performance Fast Recovery Diode
 Low Loss and Soft Recovery
 Single Diode

Part number

DHG 30 I 1200 HA

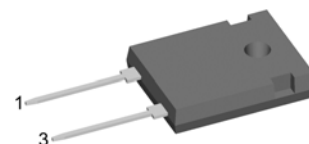

Backside: cathode

Features / Advantages:

- Planar passivated chips
- Very low leakage current
- Very short recovery time
- Improved thermal behaviour
- Very low I_{rm}-values
- Very soft recovery behaviour
- Avalanche voltage rated for reliable operation
- Soft reverse recovery for low EMI/RFI
- Low I_{rm} reduces:
 - Power dissipation within the diode
 - Turn-on loss in the commutating switch

Applications:

- Antiparallel diode for high frequency switching devices
- Antisaturation diode
- Snubber diode
- Free wheeling diode
- Rectifiers in switch mode power supplies (SMPS)
- Uninterruptible power supplies (UPS)

Package:

- Housing: TO-247
- Industry standard outline
- Epoxy meets UL 94V-0
- RoHS compliant

Ratings

Symbol	Definition	Conditions	Ratings			Unit	
			min.	typ.	max.		
V _{RRM}	max. repetitive reverse voltage	T _{VJ} = 25 °C			1200	V	
I _R	reverse current	V _R = 1200 V			50	μA	
		V _R = 1200 V			0.5	mA	
V _F	forward voltage	I _F = 30 A	T _{VJ} = 25 °C		1.95	2.26	V
						3.00	V
		I _F = 60 A	T _{VJ} = 125 °C		1.95	2.27	V
						3.20	V
I _{FAV}	average forward current	rectangular d = 0.5	T _C = 90 °C		30	A	
V _{F0}	threshold voltage	} for power loss calculation only	T _{VJ} = 150 °C		1.25	V	
r _F	slope resistance				30	mΩ	
R _{thJC}	thermal resistance junction to case				0.70	K/W	
T _{VJ}	virtual junction temperature		-55		150	°C	
P _{tot}	total power dissipation		T _C = 25 °C		180	W	
I _{FSM}	max. forward surge current	t = 10 ms (50 Hz), sine	T _{VJ} = 45 °C		200	A	
I _{RM}	max. reverse recovery current	I _F = 30 A; V _R = 600 V	T _{VJ} = 25 °C		23	A	
			T _{VJ} = 125 °C		30	A	
			T _{VJ} = 25 °C		200	ns	
t _{rr}	reverse recovery time	-di _F /dt = 600 A/μs	T _{VJ} = 125 °C		350	ns	
			T _{VJ} = 25 °C				
C _J	junction capacitance	V _R = 600 V; f = 1 MHz	T _{VJ} = 25 °C		11	pF	



DHG 30 I 1200 HA

Symbol	Definition	Conditions	Ratings			Unit
			min.	typ.	max.	
I_{RMS}	RMS current	per terminal			70	A
R_{thCH}	thermal resistance case to heatsink			0.25		K/W
T_{stg}	storage temperature		-55		150	°C
Weight				6		g
M_D	mounting torque		0.8		1.2	Nm
F_C	mounting force with clip		20		120	N

Product Marking

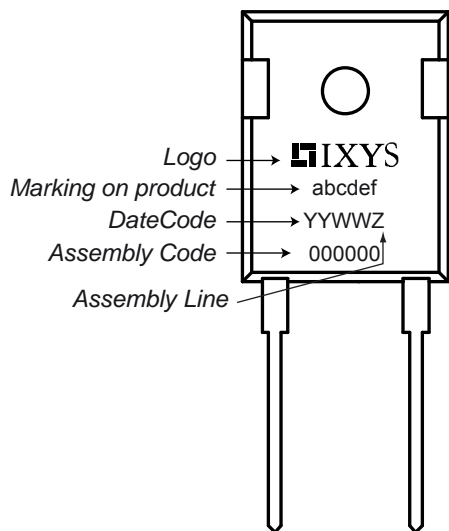

Part number

- D = Diode
- H = Sonic Fast Recovery Diode
- G = extreme fast
- 30 = Current Rating [A]
- I = Single Diode
- 1200 = Reverse Voltage [V]
- HA = TO-247AD (2)

Ordering	Part Name	Marking on Product	Delivering Mode	Base Qty	Code Key
Standard	DHG 30 I 1200 HA	DHG30I1200HA	Tube	30	503098

Similar Part	Package	Voltage Class
DSEP30-12A	TO-247AD (2)	1200
DSEP29-12A	TO-220AC (2)	1200
DSEP30-12AR	ISOPLUS247 (2)	1200
DSEP30-12CR	ISOPLUS247 (2)	1200

Outlines TO-247

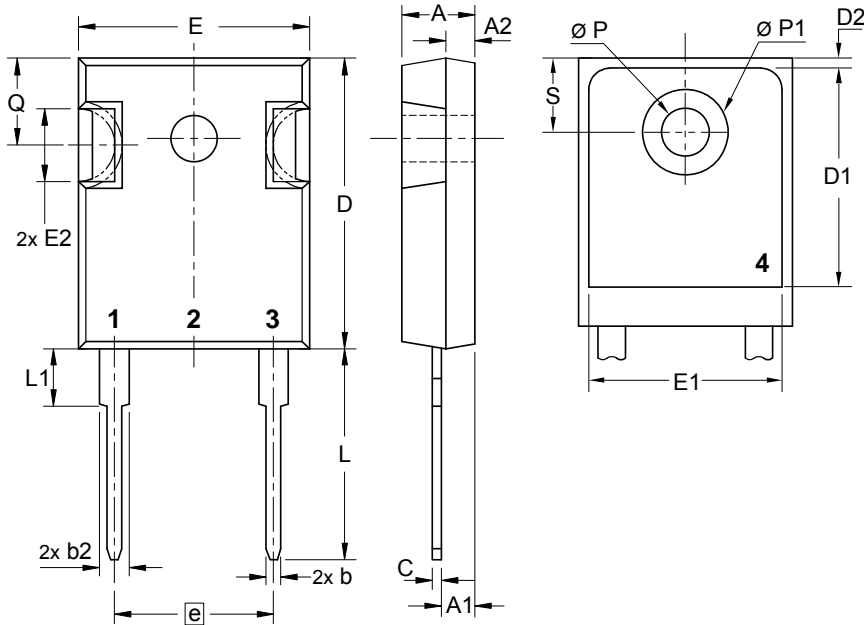

Sym.	Inches		Millimeter	
	min.	max.	min.	max.
A	0.185	0.209	4.70	5.30
A1	0.087	0.102	2.21	2.59
A2	0.059	0.098	1.50	2.49
D	0.819	0.845	20.79	21.45
E	0.610	0.640	15.48	16.24
E2	0.170	0.216	4.31	5.48
e	0.430 BSC		10.92 BSC	
L	0.780	0.800	19.80	20.30
L1	-	0.177	-	4.49
Ø P	0.140	0.144	3.55	3.65
Q	0.212	0.244	5.38	6.19
S	0.242 BSC		6.14 BSC	
b	0.039	0.055	0.99	1.40
b2	0.065	0.094	1.65	2.39
b4	0.102	0.135	2.59	3.43
c	0.015	0.035	0.38	0.89
D1	0.515	-	13.07	-
D2	0.020	0.053	0.51	1.35
E1	0.530	-	13.45	-
Ø P1	-	0.29	-	7.39

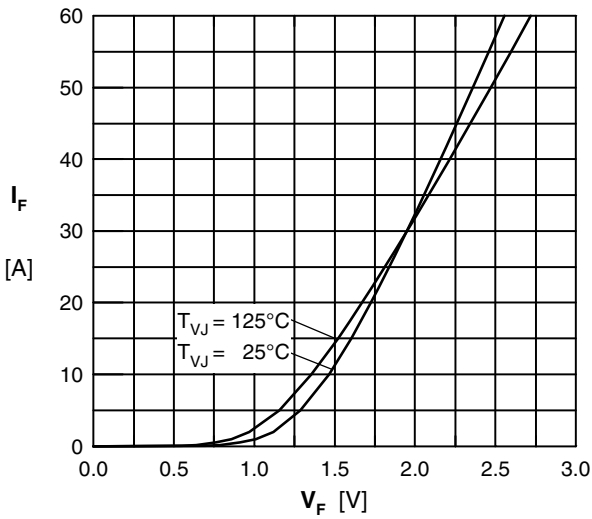

Fig. 1 Typ. Forward current versus V_F

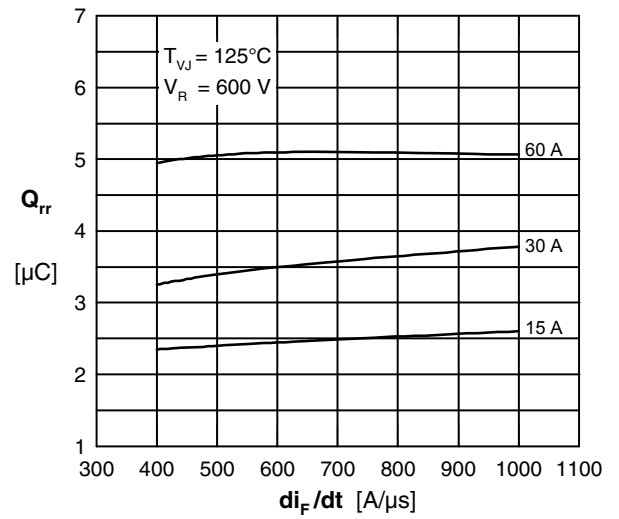

Fig. 2 Typ. reverse recov.charge Q_{rr} vs. di/dt

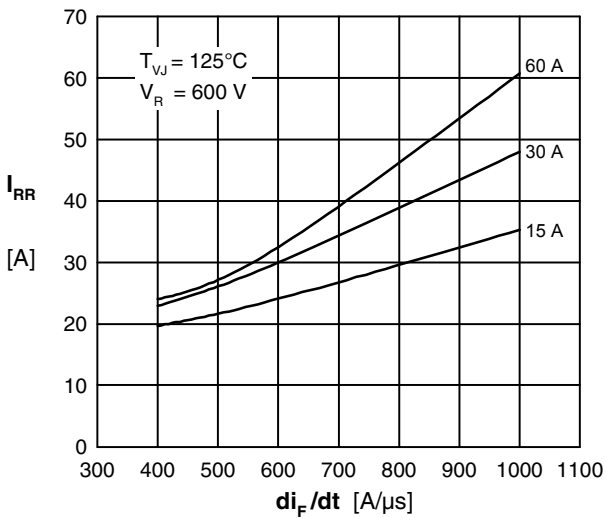

Fig. 3 Typ. peak reverse current I_{RR} vs. di/dt

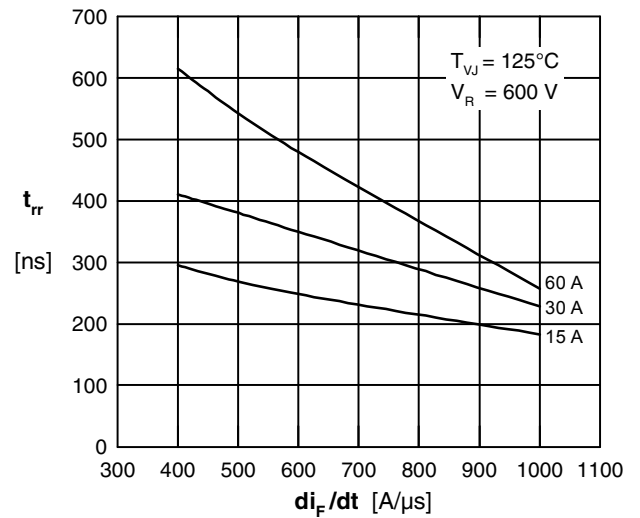

Fig. 4 Typ. recovery time t_{rr} versus di/dt

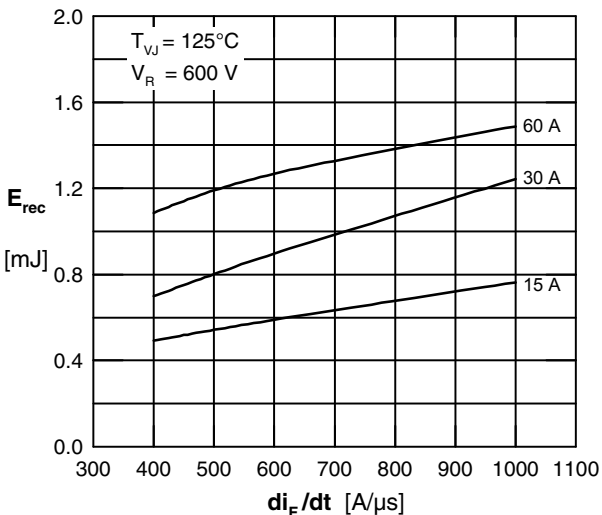

Fig. 5 Typ. recovery energy E_{rec} versus di/dt

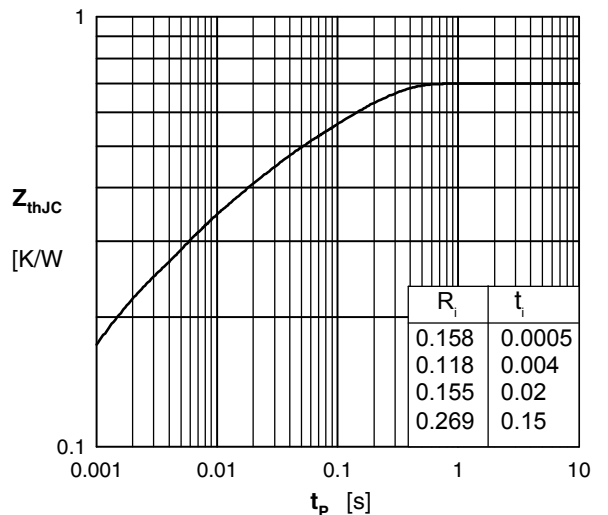

Fig. 6 Transient thermal impedance