

Excellent Integrated System Limited

Stocking Distributor

Click to view price, real time Inventory, Delivery & Lifecycle Information:

[Powerex Inc.](#)
[PM150RLA120](#)

For any questions, you can email us directly:
sales@integrated-circuit.com



Powerex, Inc., 200 E. Hillis Street, Youngwood, Pennsylvania 15697-1800 (724) 925-7272

PM150RLA120

Intellimod™ L-Series
Three Phase
IGBT Inverter + Brake
150 Amperes/1200 Volts

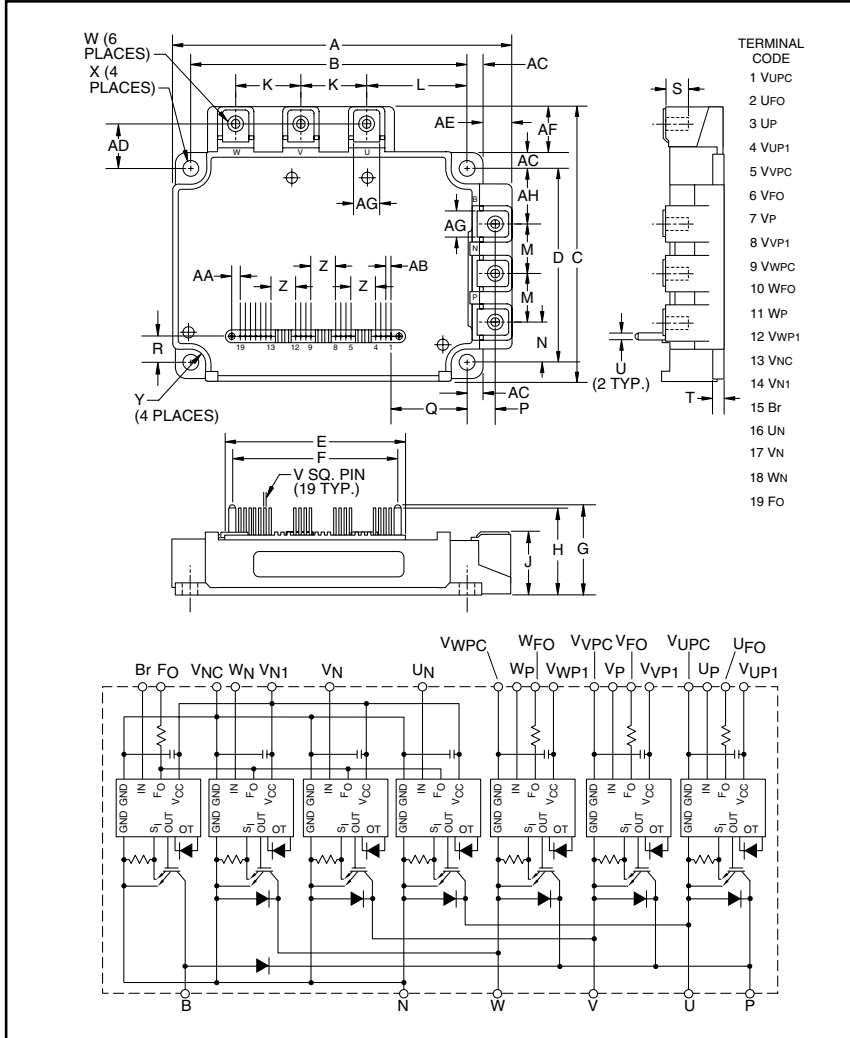

Outline Drawing and Circuit Diagram

Dimensions	Inches	Millimeters
A	5.31	135.0
B	4.33±0.02	110±0.5
C	4.33	110.0
D	3.07	78.0±0.5
E	2.81	71.5
F	2.62	66.5
G	1.37	34.7
H	1.32	33.6
J	0.95+0.04/-0.01	24.1+1.0/-0.5
K	1.02	26.0
L	1.59	40.5
M	0.79	20.0
N	0.65	16.5
P	0.43±0.01	11.0±0.3
Q	1.19	30.15
R	0.43	11.0

Dimensions	Inches	Millimeters
S	0.51	13.0
T	0.16	4.0
U	0.1 Dia.	Dia.2.5
V	0.02 Sq.	Sq. 0.5
W	M5 Metric	M5
X	0.22 Dia.	Dia. 5.5
Y	0.24 Rad.	Rad. 6
Z	0.39	10.0
AA	0.13	3.25
AB	0.08	2.0
AC	0.24	6.05
AD	0.71	18.0
AE	0.46	11.7
AF	0.74	18.7
AG	0.41	10.5
AH	0.85	21.5



Description:

Powerex Intellimod™ Intelligent Power Modules are isolated base modules designed for power switching applications operating at frequencies to 20kHz. Built-in control circuits provide optimum gate drive and protection for the IGBT and free-wheel diode power devices.

Features:

- Complete Output Power Circuit
- Gate Drive Circuit
- Protection Logic
 - Short Circuit
 - Over Temperature Using On-chip Temperature Sensing
 - Under Voltage
- Low Loss Using 5th Generation IGBT Chip

Applications:

- Inverters
- UPS
- Motion/Servo Control
- Power Supplies

Ordering Information:

Example: Select the complete part number from the table below -i.e. PM150RLA120 is a 1200V, 150 Ampere Intellimod™ Intelligent Power Module.

Type	Current Rating Amperes	V _{CEs} Volts (x 10)
PM	150	120



Powerex, Inc., 200 E. Hillis Street, Youngwood, Pennsylvania 15697-1800 (724) 925-7272

PM150RLA120
Intellimod™ L-Series
Three Phase IGBT Inverter + Brake
 150 Amperes/1200 Volts

Absolute Maximum Ratings, $T_j = 25^\circ\text{C}$ unless otherwise specified

Characteristics	Symbol	PM150RLA120	Units
Power Device Junction Temperature	T_j	-20 to 150	$^\circ\text{C}$
Storage Temperature	T_{stg}	-40 to 125	$^\circ\text{C}$
Mounting Torque, M5 Mounting Screws	—	31	in-lb
Mounting Torque, M5 Main Terminal Screws	—	31	in-lb
Module Weight (Typical)	—	800	Grams
Supply Voltage, Surge (Applied between P - N)	$V_{\text{CC(surge)}}$	1000	Volts
Self-protection Supply Voltage Limit (Short Circuit protection Capability)*	$V_{\text{CC(prot.)}}$	800	Volts
Isolation Voltage, AC 1 minute, 60Hz Sinusoidal	V_{ISO}	2500	Volts

* $V_D = 13.5 \sim 16.5\text{V}$, Inverter Part, $T_j = 125^\circ\text{C}$

IGBT Inverter Sector

Collector-Emitter Voltage ($V_D = 15\text{V}$, $V_{\text{CIN}} = 15\text{V}$)	V_{CES}	1200	Volts
Collector Current ($T_C = 25^\circ\text{C}$)	$\pm I_C$	150	Amperes
Peak Collector Current ($T_C = 25^\circ\text{C}$)	$\pm I_{\text{CP}}$	300	Amperes
Collector Dissipation ($T_C = 25^\circ\text{C}$)	P_C	801	Watts

IGBT Brake Sector

Collector-Emitter Voltage ($V_D = 15\text{V}$, $V_{\text{CIN}} = 15\text{V}$)	V_{CES}	1200	Volts
Collector Current ($T_C = 25^\circ\text{C}$)	$\pm I_C$	75	Amperes
Peak Collector Current ($T_C = 25^\circ\text{C}$)	$\pm I_{\text{CP}}$	150	Amperes
Collector Dissipation ($T_C = 25^\circ\text{C}$)	P_C	457	Watts
Diode Rated DC Reverse Voltage ($T_C = 25^\circ\text{C}$)	$V_{\text{R(DC)}}$	1200	Volts
Diode Forward Current	I_F	75	Amperes

Control Sector

Supply Voltage (Applied between $V_{\text{UP1}}-V_{\text{UPC}}$, $V_{\text{VP1}}-V_{\text{VPC}}$, $V_{\text{WP1}}-V_{\text{WPC}}$, $V_{\text{N1}}-V_{\text{NC}}$)	V_D	20	Volts
Input Voltage (Applied between U_P-V_{UPC} , V_P-V_{VPC} , W_P-V_{WPC} , U_N-V_N , W_N-Br-V_{NC})	V_{CIN}	20	Volts
Fault Output Supply Voltage (Applied between $U_{\text{FO}}-V_{\text{UPC}}$, $V_{\text{FO}}-V_{\text{VPC}}$, $W_{\text{FO}}-V_{\text{WPC}}$, F_O-V_{NC})	V_{FO}	20	Volts
Fault Output Current (U_{FO} , V_{FO} , W_{FO} , F_O Terminals)	I_{FO}	20	mA



Powerex, Inc., 200 E. Hillis Street, Youngwood, Pennsylvania 15697-1800 (724) 925-7272

PM150RLA120
Intellimod™ L-Series
Three Phase IGBT Inverter + Brake
 150 Amperes/1200 Volts

Electrical and Mechanical Characteristics, $T_j = 25^\circ\text{C}$ unless otherwise specified

Characteristics	Symbol	Test Conditions	Min.	Typ.	Max.	Units
IGBT Inverter Sector						
Collector-Emitter Cutoff Current	I_{CES}	$V_{CE} = V_{CES}, V_D = 15V, T_j = 25^\circ\text{C}$	—	—	1.0	mA
		$V_{CE} = V_{CES}, V_D = 15V, T_j = 125^\circ\text{C}$	—	—	10	mA
Diode Forward Voltage	V_{EC}	$-I_C = 150A, V_{CIN} = 15V, V_D = 15V$	—	2.5	3.5	Volts
Collector-Emitter Saturation Voltage	$V_{CE(sat)}$	$V_D = 15V, V_{CIN} = 0V, I_C = 150A,$ $T_j = 25^\circ\text{C}$	—	1.8	2.3	Volts
		$V_D = 15V, V_{CIN} = 0V, I_C = 150A,$ $T_j = 125^\circ\text{C}$	—	1.9	2.4	Volts
Inductive Load Switching Times	t_{on}	$V_D = 15V, V_{CIN} = 0 \Leftrightarrow 15V$ $V_{CC} = 600V, I_C = 150A$ $T_j = 125^\circ\text{C}$	0.5	1.0	2.5	μs
	t_{rr}		—	0.5	0.8	μs
	$t_{C(on)}$		—	0.4	1.0	μs
	t_{off}		—	2.0	3.0	μs
	$t_{C(off)}$		—	0.7	1.2	μs

IGBT Brake Sector

Collector-Emitter Cutoff Current	I_{CES}	$V_{CE} = V_{CES}, V_D = 15V, T_j = 25^\circ\text{C}$	—	—	1.0	mA
		$V_{CE} = V_{CES}, V_D = 15V, T_j = 125^\circ\text{C}$	—	—	10	mA
Diode Forward Voltage	V_{FM}	$I_F = 75A$	—	2.5	3.5	Volts
Collector-Emitter Saturation Voltage	$V_{CE(sat)}$	$V_D = 15V, V_{CIN} = 0V, I_C = 75A,$ $T_j = 25^\circ\text{C}$	—	1.8	2.3	Volts
		$V_D = 15V, V_{CIN} = 0V, I_C = 75A,$ $T_j = 125^\circ\text{C}$	—	1.9	2.4	Volts

Note 1: T_C (Base Plate) Measurement Point

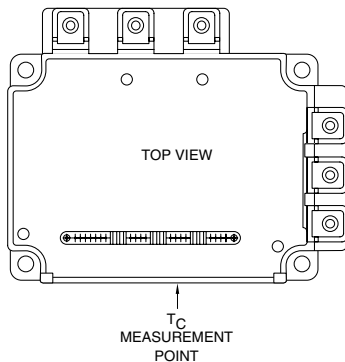



Powerex, Inc., 200 E. Hillis Street, Youngwood, Pennsylvania 15697-1800 (724) 925-7272

PM150RLA120
Intellimod™ L-Series
Three Phase IGBT Inverter + Brake
 150 Amperes/1200 Volts

Electrical and Mechanical Characteristics, $T_j = 25^\circ\text{C}$ unless otherwise specified

Characteristics	Symbol	Test Conditions	Min.	Typ.	Max.	Units
Control Sector						
Short Circuit Trip Level ($-20^\circ\text{C} \leq T_j \leq 125^\circ\text{C}$, $V_D = 15\text{V}$)	SC	Inverter Part	300	—	—	Amperes
		Brake Part	150	—	—	Amperes
Short Circuit Current Delay Time	$t_{\text{off(SC)}}$	$V_D = 15\text{V}$	—	0.2	—	μs
Over Temperature Protection (Detect T_j of IGBT Chip)	OT	Trip Level	135	145	155	$^\circ\text{C}$
		Reset Level	—	125	—	$^\circ\text{C}$
Supply Circuit Under-voltage Protection ($-20 \leq T_j \leq 125^\circ\text{C}$)	UV	Trip Level	11.5	12.0	12.5	Volts
		Reset Level	—	12.5	—	Volts
Circuit Current	I_D	$V_D = 15\text{V}$, $V_{\text{CIN}} = 15\text{V}$, $V_{\text{N1}}-V_{\text{NC}}$	—	24	34	mA
		$V_D = 15\text{V}$, $V_{\text{CIN}} = 15\text{V}$, $V_{\text{XP1}}-V_{\text{XPC}}$	—	6	12	mA
Input ON Threshold Voltage	$V_{\text{th(on)}}$	Applied between U_P-V_{UPC} ,	1.2	1.5	1.8	Volts
Input OFF Threshold Voltage	$V_{\text{th(off)}}$	V_P-V_{VPC} , W_P-V_{WPC} , U_N-V_N - W_N -Br- V_{NC}	1.7	2.0	2.3	Volts
Fault Output Current*	$I_{\text{FO(H)}}$	$V_D = 15\text{V}$, $V_{\text{CIN}} = 15\text{V}$	—	—	0.01	mA
		$V_D = 15\text{V}$, $V_{\text{CIN}} = 15\text{V}$	—	10	15	mA
Fault Output Pulse Width*	t_{FO}	$V_D = 15\text{V}$	1.0	1.8	—	ms

*Fault output is given only when the internal SC, OT and UV protections schemes of either upper or lower device operate to protect it.

Thermal Characteristics, $T_j = 25^\circ\text{C}$ unless otherwise specified

Characteristic	Symbol	Condition	Min.	Typ.	Max.	Units
Junction to Case Thermal Resistance	$R_{\text{th(j-c)Q}}$	Inverter IGBT (Per 1/6 Module) (Note 1)	—	—	0.16	$^\circ\text{C/Watt}$
	$R_{\text{th(j-c)D}}$	Inverter FWDi (Per 1/6 Module) (Note 1)	—	—	0.26	$^\circ\text{C/Watt}$
	$R_{\text{th(j-c)Q}}$	Brake IGBT (Per 1/6 Module) (Note 1)	—	—	0.27	$^\circ\text{C/Watt}$
	$R_{\text{th(j-c)D}}$	Brake FWDi (Per 1/6 Module) (Note 1)	—	—	0.40	$^\circ\text{C/Watt}$
	$R_{\text{th(j-c)Q}}$	Inverter IGBT (Per 1/6 Module)	—	—	0.12	$^\circ\text{C/Watt}$
	$R_{\text{th(j-c)D}}$	Inverter FWDi (Per 1/6 Module)	—	—	0.20	$^\circ\text{C/Watt}$
	$R_{\text{th(j-c)Q}}$	Brake IGBT (Per 1/6 Module)	—	—	0.21	$^\circ\text{C/Watt}$
	$R_{\text{th(j-c)D}}$	Brake FWDi (Per 1/6 Module)	—	—	0.31	$^\circ\text{C/Watt}$
Contact Thermal Resistance	$R_{\text{th(c-f)}}$	Case to Fin Per Module, Thermal Grease Applied	—	—	0.023	$^\circ\text{C/Watt}$

Recommended Conditions for Use

Characteristic	Symbol	Condition	Value	Units
Supply Voltage	V_{CC}	Applied across P-N Terminals	≤ 800	Volts
Control Supply Voltage**	V_D	Applied between $V_{\text{UP1}}-V_{\text{UPC}}$, $V_{\text{VP1}}-V_{\text{VPC}}$, $V_{\text{WP1}}-V_{\text{WPC}}$, $V_{\text{N1}}-V_{\text{NC}}$	15.0 ± 1.5	Volts
Input ON Voltage	$V_{\text{CIN(on)}}$	Applied between U_P-V_{UPC} ,	≤ 0.8	Volts
Input OFF Voltage	$V_{\text{CIN(off)}}$	V_P-V_{VPC} , W_P-V_{WPC} , U_N-V_N - W_N -Br- V_{NC}	≥ 9.0	Volts
PWM Input Frequency	f_{PWM}	—	≤ 20	kHz
Arm Shoot-through Blocking Time	t_{DEAD}	Input Signal	≥ 2.5	μs

** With ripple satisfying the following conditions: dv/dt swing $\leq \pm 5\text{V}/\mu\text{s}$, Variation $\leq 2\text{V}$ peak to peak.



Powerex, Inc., 200 E. Hillis Street, Youngwood, Pennsylvania 15697-1800 (724) 925-7272

PM150RLA120
Intellimod™ L-Series
Three Phase IGBT Inverter + Brake
 150 Amperes/1200 Volts

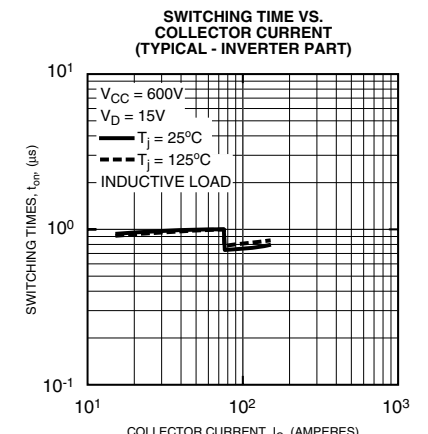
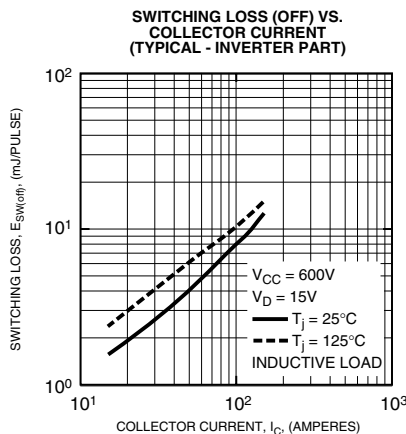
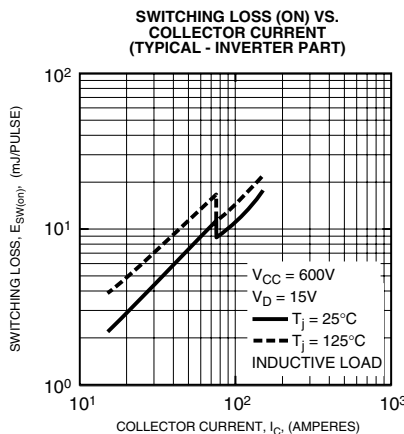
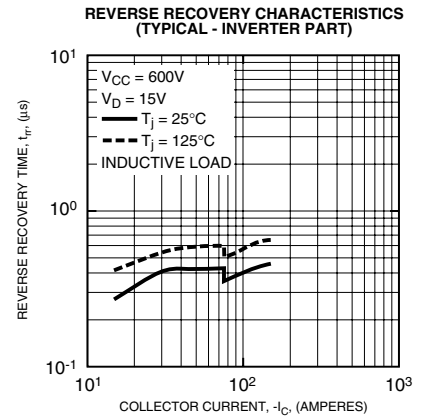
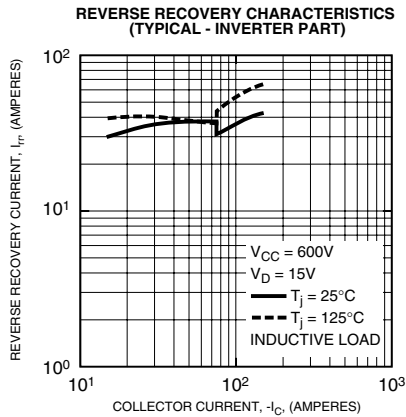
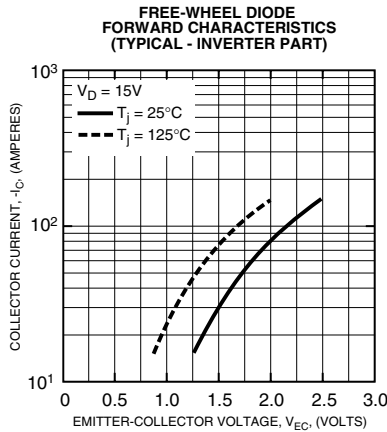
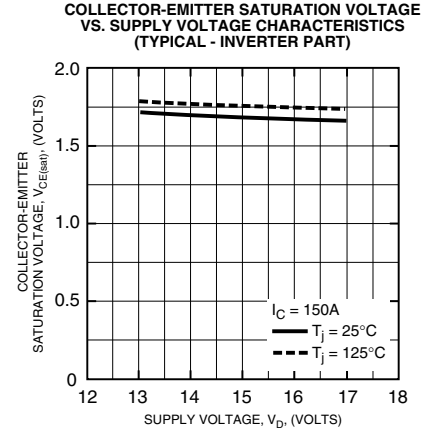
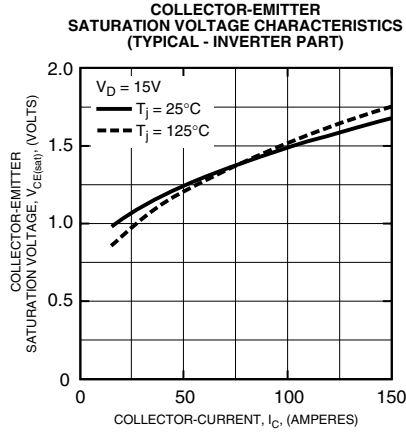
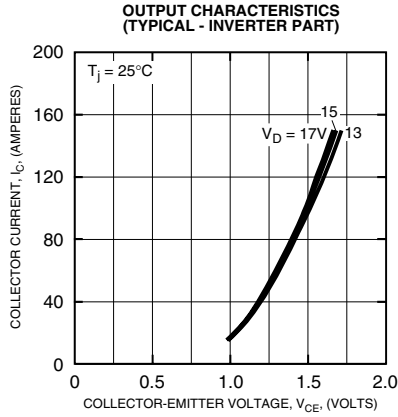



Powerex, Inc., 200 E. Hillis Street, Youngwood, Pennsylvania 15697-1800 (724) 925-7272

PM150RLA120
Intellimod™ L-Series
Three Phase IGBT Inverter + Brake
 150 Amperes/1200 Volts

