

Excellent Integrated System Limited

Stocking Distributor

Click to view price, real time Inventory, Delivery & Lifecycle Information:

[Integrated Device Technology \(IDT\)](#)
[ICS670M-02](#)

For any questions, you can email us directly:
sales@integrated-circuit.com

LOW PHASE NOISE ZERO DELAY BUFFER AND MULTIPLIER

ICS670-02

Description

The ICS670-02 is a high speed, low phase noise, Zero Delay Buffer (ZDB) which integrates IDT's proprietary analog/digital Phase Locked Loop (PLL) techniques. Part of IDT's ClockBlocks™ family, the part's zero delay feature means that the rising edge of the input clock aligns with the rising edges of the outputs giving the appearance of no delay through the device. There are two identical outputs on the chip. The FBCLK should be used to connect to the FBIN. Each output has its own output enable pin.

The ICS670-02 is ideal for synchronizing outputs in a large variety of systems, from personal computers to data communications to video. By allowing off-chip feedback paths, the chip can eliminate the delay through other devices. The 15 different on-chip multipliers work in a variety of applications. For other multipliers, including functional multipliers, see the ICS527.

Features

- Packaged in 16-pin SOIC
- Available in Pb (lead) free package
- Clock inputs from 5 to 160 MHz (see page 2)
- Patented PLL with low phase noise
- Output clocks up to 160 MHz at 3.3 V
- 15 selectable on-chip multipliers
- Power down mode available
- Low phase noise: -111 dBc/Hz at 10 kHz
- Output enable function tri-states outputs
- Low jitter 15 ps one sigma
- Advanced, low power, sub-micron CMOS process
- Operating voltage of 3.3 V or 5 V
- Industrial temperature range available (-40 to +85°C)

Block Diagram

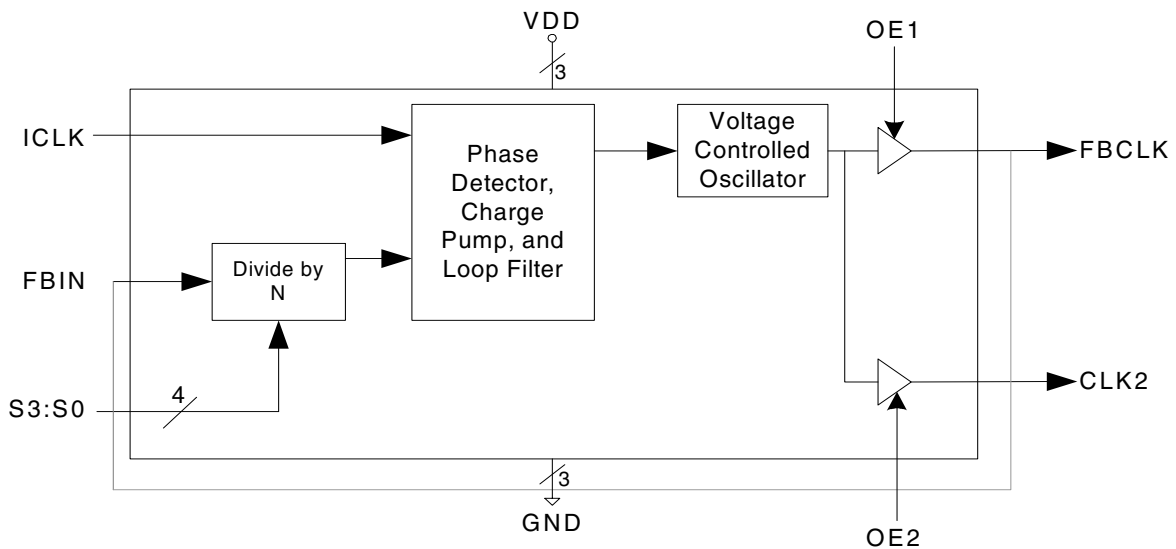

External Feedback from FBCLK is recommended.

ICS670-02

LOW PHASE NOISE ZERO DELAY BUFFER AND MULTIPLIER

ZDB AND MULTIPLIER

Pin Assignment

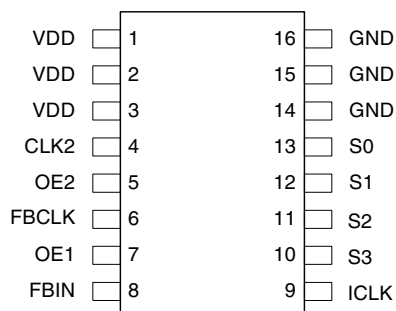

Multiplier Select Table

S3	S2	S1	S0	CLK2 (and FBCLK)	Input Range (MHz)
0	0	0	0	Low (Power down entire chip)	-
0	0	0	1	Input x1.333	18 - 120
0	0	1	0	Input x6	5 - 26.67
0	0	1	1	Input x1.5	16.67 - 107
0	1	0	0	Input x3.333	7.5 - 48
0	1	0	1	Input x2.50	10 - 64
0	1	1	0	Input x4	6 - 40
0	1	1	1	Input x1	25 - 160
1	0	0	0	Input x2.333	11 - 69
1	0	0	1	Input x2.666	10 - 60
1	0	1	0	Input x12	5 - 13.33
1	0	1	1	Input x3	8 - 53.33
1	1	0	0	Input x10	5 - 16
1	1	0	1	Input x5	6 - 32
1	1	1	0	Input x8	5 - 20
1	1	1	1	Input x2	12 - 80

Pin Descriptions

Pin Number	Pin Name	Pin Type	Pin Description
1 - 3	VDD	Input	Power supply. Connect both pins to the same voltage (either 3.3 V or 5 V).
4	CLK2	Output	Clock output from VCO. Output frequency equals the input frequency times multiplier.
5	OE2	Input	Output clock enable 2. Tri-states the clock 2 output when low.
6	FBCLK	Output	Clock output from VCO. Output frequency equals the input frequency times multiplier.
7	OE1	Input	Output clock enable 1. Tri-states the feedback clock output when low.
8	FBIN	Input	Feedback clock input.
9	ICLK	Input	Clock input. Connect to a 5 - 160 MHz clock.
10	S3	Input	Multiplier select pin 3. Determines outputs per table above. Internal pull-up.
11	S2	Input	Multiplier select pin 2. Determines outputs per table above. Internal pull-up.
12	S1	Input	Multiplier select pin 1. Determines outputs per table above. Internal pull-up.
13	S0	Input	Multiplier select pin 0. Determines outputs per table above. Internal pull-up.
14 - 16	GND	Power	Connect to ground.

External Components

The ICS670-02 requires a minimum number of external components for proper operation. Decoupling capacitors of 0.01 μ F should be connected between VDD and GND on pins 4 and 5, and VDD and GND on pins 13 and 12, as close to the device as possible. A series termination resistor of 33 Ω may be used to each clock output pin to reduce reflections.

Absolute Maximum Ratings

Stresses above the ratings listed below can cause permanent damage to the ICS670-02. These ratings, which are standard values for IDT commercially rated parts, are stress ratings only. Functional operation of the device at these or any other conditions above those indicated in the operational sections of the specifications is not implied. Exposure to absolute maximum rating conditions for extended periods can affect product reliability. Electrical parameters are guaranteed only over the recommended operating temperature range.

Item	Rating
Supply Voltage, VDD	7 V
All Inputs and Outputs	-0.5 V to VDD+0.5 V
Ambient Operating Temperature	0 to +70°C
Storage Temperature	-65 to +150°C
Junction Temperature	150°C
Soldering Temperature	260°C

Recommended Operation Conditions

Parameter	Min.	Typ.	Max.	Units
Ambient Operating Temperature	0		+70	°C
Power Supply Voltage (measured in respect to GND)	+3.0		+5.5	V

DC Electrical Characteristics

VDD=3.3 V \pm 10%, Ambient temperature -40 to +85°C, unless stated otherwise

Parameter	Symbol	Conditions	Min.	Typ.	Max.	Units
Operating Voltage	VDD		3.0		5.5	V
Input High Voltage	V _{IH}		2			V
Input Low Voltage	V _{IL}				0.8	V
Output High Voltage	V _{OH}	I _{OH} = -12 mA	2.4			V
Output Low Voltage	V _{OL}	I _{OL} = 12 mA			0.4	V
Output High Voltage, CMOS level	V _{OH}	I _{OH} = -4 mA	VDD-0.4			V
Operating Supply Current	IDD	No Load		35		mA

ICS670-02

LOW PHASE NOISE ZERO DELAY BUFFER AND MULTIPLIER

ZDB AND MULTIPLIER

Parameter	Symbol	Conditions	Min.	Typ.	Max.	Units
Short Circuit Current	I _{OS}	Each output		±50		mA
Internal Pull-up Resistor	R _{PU}	OE, select pins		200		kΩ
Input Capacitance	C _{IN}	OE, select pins		5		pF

AC Electrical Characteristics

VDD = 3.3V ±10%, Ambient Temperature -40 to +85°C, unless stated otherwise

Parameter	Symbol	Conditions	Min.	Typ.	Max.	Units
Input Clock Frequency	f _{IN}	See table on page 2	5		160	MHz
Output Clock Frequency					160	MHz
Output Rise Time	t _{OR}	0.8 to 2.0 V, no load			1.5	ns
Output Fall Time	t _{OF}	2.0 to 0.8 V, no load			1.5	ns
Output Clock Duty Cycle	t _{DC}	measured at VDD/2	45	50	55	%
Input to Output Skew		Note 1		±100		ps
Maximum Absolute Jitter		short term		±45		ps
Maximum Jitter		one sigma		15		ps
Phase Noise, relative to carrier, 125 MHz (x5)		100 Hz offset		-103		dBc/Hz
		1 kHz offset		-117		dBc/Hz
		10 kHz		-111		dBc/Hz
		200 kHz		-88		dBc/Hz

Note 1: Rising edge of ICLK compared with rising edge of CLK2, with FBCLK connected to FBIN, and 15 pF load on CLK2.

Thermal Characteristics

Parameter	Symbol	Conditions	Min.	Typ.	Max.	Units
Thermal Resistance Junction to Ambient	θ _{JA}	Still air		120		°C/W
	θ _{JA}	1 m/s air flow		115		°C/W
	θ _{JA}	3 m/s air flow		105		°C/W
Thermal Resistance Junction to Case	θ _{JC}			58		°C/W

Phase Noise for 125 MHz output, 25 MHz clock input (VDD = 3.3 V)

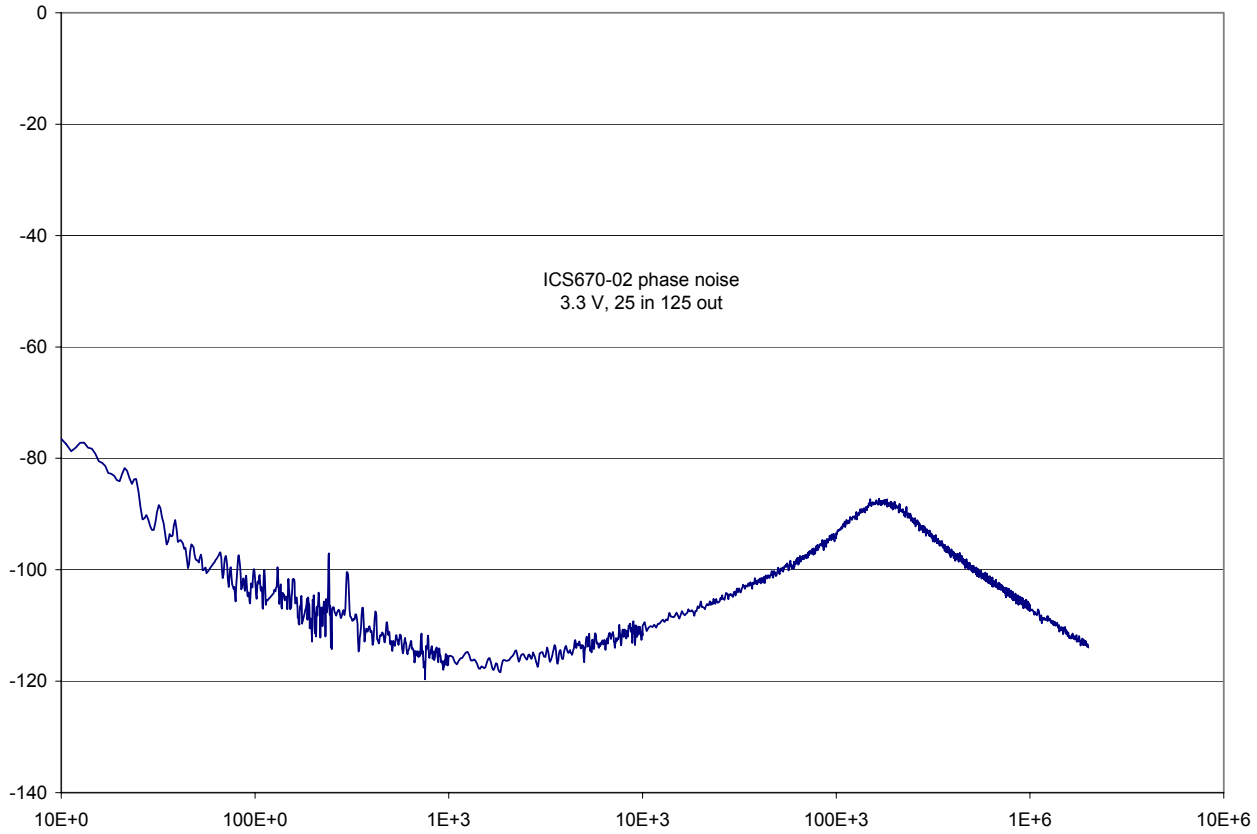

ICS670-02
LOW PHASE NOISE ZERO DELAY BUFFER AND MULTIPLIER **ZDB AND MULTIPLIER**

Package Outline and Package Dimensions (16-pin SOIC, 150 Mil. Narrow Body)

Package dimensions are kept current with JEDEC Publication No. 95

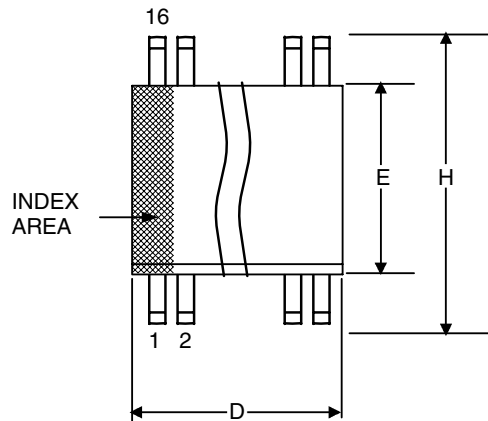

Symbol	Millimeters		Inches	
	Min	Max	Min	Max
A	1.35	1.75	.0532	.0688
A1	0.10	0.25	.0040	.0098
B	0.33	0.51	.013	.020
C	0.19	0.25	.0075	.0098
D	9.80	10.00	.3859	.3937
E	3.80	4.00	.1497	.1574
e	1.27 BASIC		0.050 BASIC	
H	5.80	6.20	.2284	.2440
h	0.25	0.50	.010	.020
L	0.40	1.27	.016	.050
α	0°	8°	0°	8°

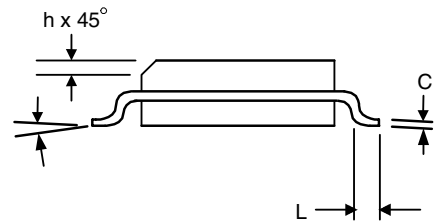
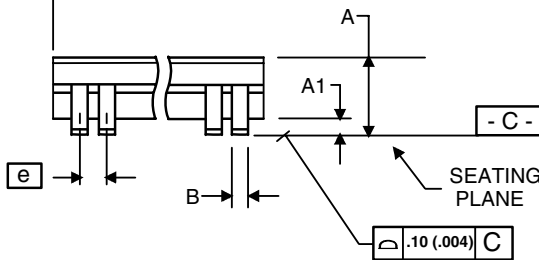

Ordering Information

Part / Order Number	Marking	Shipping Packaging	Package	Temperature
ICS670M-02	ICS670M-02	Tubes	16-pin SOIC	0 to +70°C
ICS670M-02T	ICS670M-02	Tape and Reel	16-pin SOIC	0 to +70°C
ICS670M-02LF	670M-02LF	Tubes	16-pin SOIC	0 to +70°C
ICS670M-02LFT	670M-02LF	Tape and Reel	16-pin SOIC	0 to +70°C
ICS670MI-02LF	670MI-02LF	Tubes	16-pin SOIC	-40 to +85°C
ICS670MI-02LFT	670MI-02LF	Tape and Reel	16-pin SOIC	-40 to +85°C

Parts that are ordered with a "LF" suffix to the part number are the Pb-Free configuration and are RoHS compliant.

While the information presented herein has been checked for both accuracy and reliability, Integrated Device Technology (IDT) assumes no responsibility for either its use or for the infringement of any patents or other rights of third parties, which would result from its use. No other circuits, patents, or licenses are implied. This product is intended for use in normal commercial applications. Any other applications such as those requiring extended temperature range, high reliability, or other extraordinary environmental requirements are not recommended without additional processing by IDT. IDT reserves the right to change any circuitry or specifications without notice. IDT does not authorize or warrant any IDT product for use in life support devices or critical medical instruments.

ICS670-02

LOW PHASE NOISE ZERO DELAY BUFFER AND MULTIPLIER

ZDB AND MULTIPLIER

Innovate with IDT and accelerate your future networks. Contact:

www.IDT.com

For Sales

800-345-7015
408-284-8200
Fax: 408-284-2775

For Tech Support

408-284-4522
clockhelp@idt.com

Corporate Headquarters

Integrated Device Technology, Inc.
6024 Silver Creek Valley Road
San Jose, CA 95138
United States
800 345 7015
+408 284 8200 (outside U.S.)

Asia Pacific and Japan

Integrated Device Technology
Singapore (1997) Pte. Ltd.
Reg. No. 199707558G
435 Orchard Road
#20-03 Wisma Atria
Singapore 238877
+65 6 887 5505

Europe

IDT Europe, Limited
321 Kingston Road
Leatherhead, Surrey
KT22 7TU
England
+44 1372 363 339