

Excellent Integrated System Limited

Stocking Distributor

Click to view price, real time Inventory, Delivery & Lifecycle Information:

[Newhaven Display Intl](#)

[NHD-C12832A1Z-NSW-BBW-3V3](#)

For any questions, you can email us directly:

sales@integrated-circuit.com



NHD-C12832A1Z-NSW-BBW-3V3

COG (Chip-On-Glass) Liquid Crystal Display Module

NHD-	Newhaven Display
C12832-	128 x 32 pixels
A1Z-	Model
N-	Transmissive
SW-	Side White LED Backlight
B-	STN- Blue
B-	6:00 view
W-	Wide Temp (-20°C ~ +70°C)
3V3-	3Vdd, 3V Backlight
	RoHS Compliant

Newhaven Display International, Inc.

2511 Technology Drive, Suite 101

Elgin IL, 60124

Ph: 847-844-8795

Fax: 847-844-8796

www.newhavendisplay.com

nhtech@newhavendisplay.com

nhsales@newhavendisplay.com

Document Revision History

Revision	Date	Description	Changed by
0	11/12/2008	Initial Release	-
1	5/18/2009	User guide reformat	BE
2	10/12/2009	Updated Electrical Characteristic	MC
3	5/6/2013	Electrical and Optical characteristics updated. Pin description, wiring diagram, mechanical drawing page and example initialization program updated.	JN

Functions and Features

- 128 x 32 pixels
- 4-line SPI MPU interfaces
- Built-in ST7565R controller
- 3V power supply
- 1/33 duty cycle; 1/6 bias
- RoHS Compliant

Mechanical Drawing

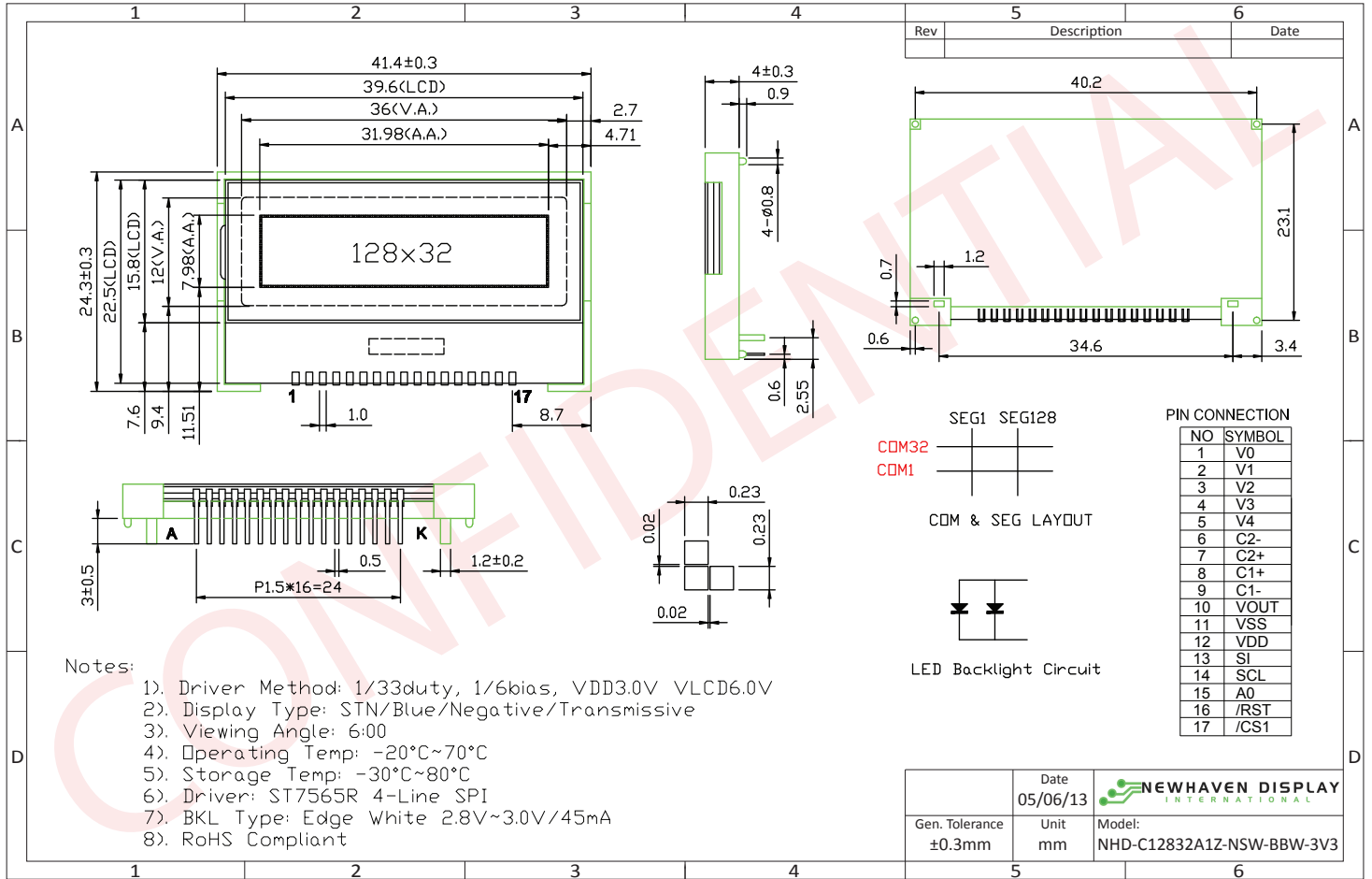

The drawing contained herein is the exclusive property of Newhaven Display International, Inc. and shall not be copied, reproduced, and/or disclosed in any format without permission.

Pin Description and Wiring Diagram

Pin No.	Symbol	External Connection	Function Description
1	V0	Power Supply	0.47uF-2.2uF Cap to VSS
2	V1	Power Supply	0.47uF -2.2uF Cap to VSS
3	V2	Power Supply	0.47uF -2.2uF Cap to VSS
4	V3	Power Supply	0.47uF -2.2uF Cap to VSS
5	V4	Power Supply	0.47uF 2.2uF Cap to VSS
6	C2-	Power Supply	Connect to 1uF Cap to C2+ (pin 7)
7	C2+	Power Supply	Connect to 1uF Cap to C2- (pin 6)
8	C1+	Power Supply	Connect to 1uF Cap to C1- (pin 9)
9	C1-	Power Supply	Connect to 1uF Cap to C1+ (pin 8)
10	VOUT	Power Supply	Connect to 1uF cap to VSS (pin 11)
11	VSS	Power Supply	Ground
12	VDD	Power Supply	Power supply for LCD and logic (+3V)
13	SI	MPU	Serial Data
14	SCL	MPU	Serial Clock
15	A0	MPU	Select registers. 0: Instruction, 1: Data register
16	/RST	MPU	Active LOW Reset signal
17	/CS1	MPU	Active LOW Chip Select signal
A	LED+	Power Supply	Power supply for LED Backlight (+3V)
K	LED-	Power Supply	Ground for Backlight

Recommended LCD connector: 1.5mm pitch pins, solder directly into PCB

Backlight connector: 1.2mm Wide pins, solder directly into PCB **Mates with:** ---

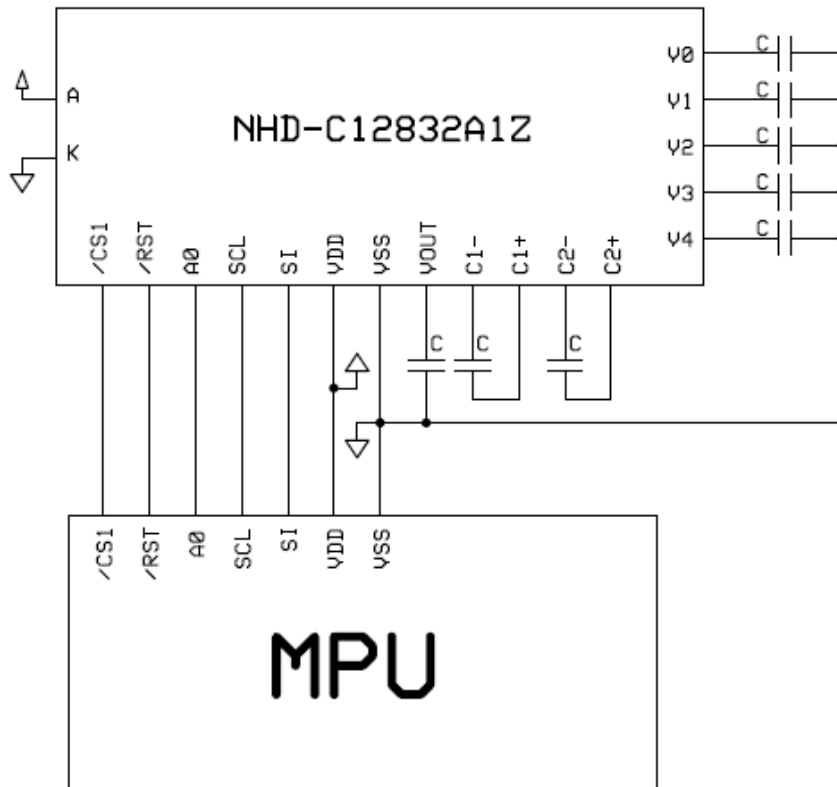

Electrical Characteristics

Item	Symbol	Condition	Min.	Typ.	Max.	Unit
Operating Temperature Range	Top	Absolute Max	-20	-	+70	°C
Storage Temperature Range	Tst	Absolute Max	-30	-	+80	°C
Supply Voltage	VDD		2.7	3.0	3.3	V
Supply Current	IDD	Ta=25°C, VDD=3.0V	-	0.25	0.45	mA
Supply for LCD (contrast)	VDD-V0	Ta=25°C	-	6.0	-	V
"H" Level input	Vih		0.8*VDD	-	VDD	V
"L" Level input	Vil		VSS	-	0.2*VDD	V
"H" Level output	Voh		0.8*VDD	-	VDD	V
"L" Level output	Vol		VSS	-	0.2*VDD	V
Backlight supply voltage	VLED		-	3.0	-	V
Backlight supply current	ILED	VLED=3.0V	20	30	45	mA

Optical Characteristics

Item	Symbol	Condition	Min.	Typ.	Max.	Unit
Viewing Angle - Top		Cr≥2	-	25	-	°
Viewing Angle - Bottom			-	50	-	°
Viewing Angle - Left			-	30	-	°
Viewing Angle - Right			-	30	-	°
Contrast Ratio	CR		-	2	-	-
Response Time (rise)	Tr	-	-	120	150	ms
Response Time (fall)	Tf	-	-	120	150	ms

Controller Information

Built-in ST7565R controller.

Please download specification at http://www.newhavendisplay.com/app_notes/ST7565R.pdf

Timing Characteristics

The 4-line SPI Interface

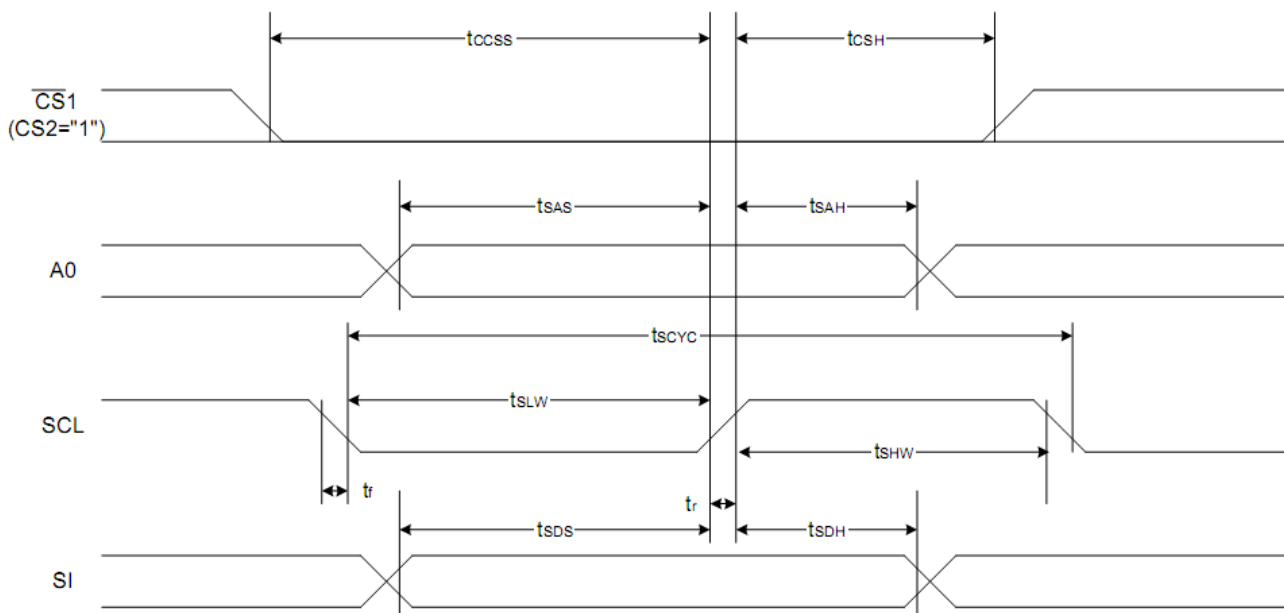

Item	Signal	Symbol	Condition	Rating		Units
				Min.	Max.	
4-line SPI Clock Period	SCL	T_{scyc}		50	—	ns
SCL "H" pulse width		T_{shw}		25	—	
SCL "L" pulse width		T_{slw}		25	—	
Address setup time	A0	T_{sas}		20	—	
Address hold time		T_{sah}		10	—	
Data setup time	SI	T_{sds}		20	—	
Data hold time		T_{sdh}		10	—	
CS-SCL time	CS	T_{css}		20	—	
CS-SCL time		T_{csh}		40	—	

*1 The input signal rise and fall time (t_r , t_f) are specified at 15 ns or less.

*2 All timing is specified using 20% and 80% of V_{DD} as the standard.

Reset Timing

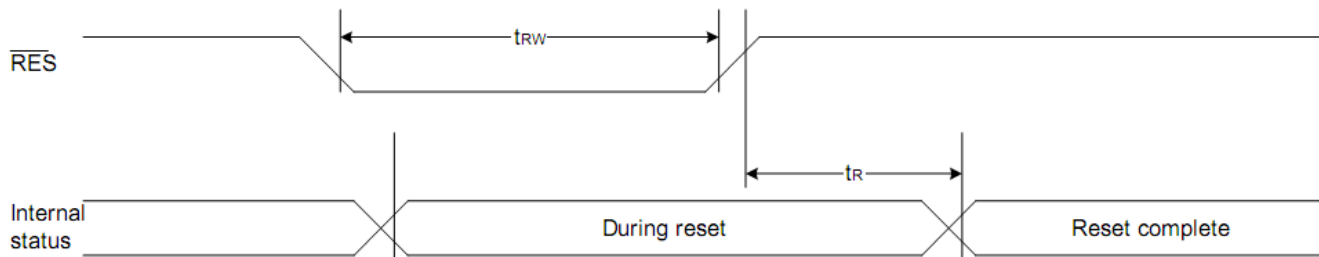

Table of Commands

Command	Command Code										Function		
	A0	/RD	/WR	D7	D6	D5	D4	D3	D2	D1		D0	
(1) Display ON/OFF	0	1	0	1	0	1	0	1	1	1	0	1	LCD display ON/OFF 0: OFF, 1: ON
(2) Display start line set	0	1	0	0	1	Display start address					0	Sets the display RAM display start line address	
(3) Page address set	0	1	0	1	0	1	1	Page address				0	Sets the display RAM page address
(4) Column address set upper bit Column address set lower bit	0	1	0	0	0	0	1	Most significant column address				0	Sets the most significant 4 bits of the display RAM column address.
				0	0	0	0	Least significant column address				0	Sets the least significant 4 bits of the display RAM column address.
(5) Status read	0	0	1	Status				0	0	0	0	0	Reads the status data
(6) Display data write	1	1	0	Write data							0	Writes to the display RAM	
(7) Display data read	1	0	1	Read data							0	Reads from the display RAM	
(8) ADC select	0	1	0	1	0	1	0	0	0	0	0	1	Sets the display RAM address SEG output correspondence 0: normal, 1: reverse
(9) Display normal/reverse	0	1	0	1	0	1	0	0	1	1	0	1	Sets the LCD display normal/ reverse 0: normal, 1: reverse
(10) Display all points ON/OFF	0	1	0	1	0	1	0	0	1	0	0	1	Display all points 0: normal display 1: all points ON
(11) LCD bias set	0	1	0	1	0	1	0	0	0	1	0	1	Sets the LCD drive voltage bias ratio 0: 1/9 bias, 1: 1/7 bias (ST7565R)
(12) Read-modify-write	0	1	0	1	1	1	0	0	0	0	0	0	Column address increment At write: +1 At read: 0
(13) End	0	1	0	1	1	1	0	1	1	1	0	0	Clear read/modify/write
(14) Reset	0	1	0	1	1	1	0	0	0	1	0	0	Internal reset
(15) Common output mode select	0	1	0	1	1	0	0	0	*	*	*	*	Select COM output scan direction 0: normal direction 1: reverse direction
(16) Power control set	0	1	0	0	0	1	0	1	Operating mode			0	Select internal power supply operating mode
(17) V ₀ voltage regulator internal resistor ratio set	0	1	0	0	0	1	0	0	Resistor ratio			0	Select internal resistor ratio(Rb/Ra) mode
(18) Electronic volume mode set Electronic volume register set	0	1	0	1	0	0	0	0	0	0	0	1	Set the V ₀ output voltage electronic volume register
				0	0	Electronic volume value					0		
(19) Sleep mode set	0	1	0	1	0	1	0	1	1	0	0	0	0: Sleep mode, 1: Normal mode
				*	*	*	*	*	*	0	0		
(20) Booster ratio set	0	1	0	1	1	1	1	1	0	0	0	0	select booster ratio 00: 2x,3x,4x 01: 5x 11: 6x
				0	0	0	0	0	0	0	step-up value		
(21) NOP	0	1	0	1	1	1	0	0	0	1	1	1	Command for non-operation
(22) Test	0	1	0	1	1	1	1	*	*	*	*	*	Command for IC test. Do not use this command

Example Initialization Program

```
void data_out(unsigned char i) //Data Output Serial Interface
{
    unsigned int n;
    CS = 0;
    A0 = 1;
    for(n=0; n<8; n++){
        i <<=1;
        SCL = 0;
        P1 = i;
        delay(2);
        SCL = 1;
    }
    CS = 1;
}

void comm_out(unsigned char j) //Command Output Serial Interface
{
    unsigned int n;
    CS = 0;
    A0 = 0;
    for(n=0; n<8; n++){
        j <<=1;
        SCL = 0;
        P1 = j;
        delay(2);
        SCL = 1;
    }
    CS = 1;
}

/*****
*      Initialization For controller      *
*****/
void init_LCD()
{
    comm_out(0xA0);
    comm_out(0xAE);
    comm_out(0xC0);
    comm_out(0xA2);
    comm_out(0x2F);
    comm_out(0x21);
    comm_out(0x81);
    comm_out(0x3F);
}
/*****/
```

Quality Information

Test Item	Content of Test	Test Condition	Note
High Temperature storage	Endurance test applying the high storage temperature for a long time.	+80°C , 48hrs	2
Low Temperature storage	Endurance test applying the low storage temperature for a long time.	-30°C , 48hrs	1,2
High Temperature Operation	Endurance test applying the electric stress (voltage & current) and the high thermal stress for a long time.	+70°C 48hrs	2
Low Temperature Operation	Endurance test applying the electric stress (voltage & current) and the low thermal stress for a long time.	-20°C , 48hrs	1,2
High Temperature / Humidity Operation	Endurance test applying the electric stress (voltage & current) and the high thermal with high humidity stress for a long time.	+40°C , 90% RH , 48hrs	1,2
Thermal Shock resistance	Endurance test applying the electric stress (voltage & current) during a cycle of low and high thermal stress.	-0°C,30min -> 25°C,5min -> 50°C,30min = 1 cycle 10 cycles	
Vibration test	Endurance test applying vibration to simulate transportation and use.	10-55Hz , 15mm amplitude. 60 sec in each of 3 directions X,Y,Z For 15 minutes	3
Static electricity test	Endurance test applying electric static discharge.	VS=800V, RS=1.5kΩ, CS=100pF One time	

Note 1: No condensation to be observed.

Note 2: Conducted after 4 hours of storage at 25°C, 0%RH.

Note 3: Test performed on product itself, not inside a container.

Precautions for using LCDs/LCMs

See Precautions at www.newhavendisplay.com/specs/precautions.pdf

Warranty Information and Terms & Conditions

http://www.newhavendisplay.com/index.php?main_page=terms