

## Excellent Integrated System Limited

Stocking Distributor

Click to view price, real time Inventory, Delivery & Lifecycle Information:

[Maxim Integrated](#)  
[MAX8845ZEVKIT+](#)

For any questions, you can email us directly:

[sales@integrated-circuit.com](mailto:sales@integrated-circuit.com)

19-4340; Rev 1; 9/09

EVALUATION KIT  
 AVAILABLE



# 28V Linear Li+ Battery Chargers with Battery Detection and Overvoltage Protected Output

## General Description

The MAX8845Z/MAX8845Y/MAX8845X/MAX8845W are intelligent, stand-alone constant-current, constant-voltage (CCCV), thermally regulated linear chargers designed for charging a single-cell lithium-ion (Li+) battery. The MAX8845Z/MAX8845Y/MAX8845X/MAX8845W integrate a current-sense circuit, MOSFET pass element, thermal-regulation circuitry, and eliminate the external reverse-blocking Schottky diode to create the simplest and smallest charging solutions for handheld equipment.

The ICs control the charging sequence from the pre-qualification state through constant current fast-charge, top-off charge, and full-charge indication. Proprietary thermal-regulation circuitry limits the die temperature during fast-charging or when the ICs are exposed to high ambient temperatures, allowing maximum charging current without damaging the ICs.

The MAX8845Z/MAX8845Y/MAX8845X/MAX8845W achieve high flexibility by providing adjustable fast-charge currents (SETI) and an adjustable top-off current threshold (MIN) through external resistors. The MAX8845Z/MAX8845Y/MAX8845X/MAX8845W feature a booting assistant circuit that distinguishes input sources and battery connection and provides an enable signal (ABO—MAX8845Z and  $\overline{\text{ABO}}$ —MAX8845Y/MAX8845X/MAX8845W) for system booting.

The MAX8845Z/MAX8845Y/MAX8845X/MAX8845W also integrate an overvoltage-protected output (SAFEOUT) for low voltage-rated USB or charger inputs in system, and a battery-pack detection circuit (DETBAT) that disables the charger when the battery pack is absent. Other features include an active-low control input ( $\overline{\text{EN}}$ ), an active-low input power source detection output (POK), and a fully charged top-off threshold detection output (CHG).

The MAX8845Z/MAX8845Y/MAX8845X/MAX8845W accept an input supply range from 4.25V (4.4V for MAX8845W only) to 28V, but disable charging if the supply voltage exceeds +7.5V (+8.0V for MAX8845X only) to protect against unqualified or faulty AC adapters. The ICs operate over the extended temperature range (-40°C to +85°C) and are available in a compact 12-pin, thermally enhanced thin QFN, 3mm x 3mm package (0.8mm max height).

## Applications

- Cellular and Cordless Phones
- Smart Phones and PDAs
- Digital Still Cameras
- MP3 Players
- USB Appliances
- Charging Cradles and Docks
- Bluetooth® Equipment

## Features

- ◆ CCCV, Thermally Regulated Linear 1-Cell Li+ Battery Charger
- ◆ No External MOSFET, Reverse Blocking Diode, or Current-Sense Resistor
- ◆ Programmable Fast-Charge Currents (1A<sub>RMS</sub> max)
- ◆ Programmable Top-Off Current Threshold (MIN)
- ◆ Input Overvoltage Protected 4.7V Output (MAX8845Z/MAX8845Y/MAX8845W) or 4.85V (MAX8845X) (SAFEOUT)
- ◆ Proprietary Die Temperature Regulation Control (+115°C)
- ◆ 4.25V (4.4V for MAX8845W only) to 28V Input Voltage Range with Input Overvoltage Protection Above +7.5V (+8.0V for MAX8845X only)
- ◆ Low-Dropout Voltage (300mV at 500mA)
- ◆ Input Power-Source Detection Output (POK), Charge Status Output (CHG), Charge-Enable Input ( $\overline{\text{EN}}$ )
- ◆ Output for Autobooting (ABO—MAX8845Z,  $\overline{\text{ABO}}$ —MAX8845Y/MAX8845X/MAX8845W)
- ◆ Tiny, 3mm x 3mm 12-Pin Thin QFN Package, 0.8mm Height (max)

## Ordering Information

PART	PIN-PACKAGE	TOP MARK	ABO ACTIVE STATE
MAX8845ZETC+	12 Thin QFN-EP*	ABL	Active high
MAX8845YETC+	12 Thin QFN-EP*	ABM	Active low
MAX8845XETC+	12 Thin QFN-EP*	ABQ	Active low
MAX8845WETC+	12 Thin QFN-EP*	ABR	Active low

Note: All devices are specified over the -40°C to +85°C operating temperature range.

+Denotes a lead(Pb)-free/RoHS-compliant package.

\*EP = Exposed pad.

Typical Operating Circuit and Pin Configurations appear at end of data sheet.

Bluetooth is a registered trademark of Bluetooth SIG.



# 28V Linear Li+ Battery Chargers with Battery Detection and Overvoltage Protected Output

## ABSOLUTE MAXIMUM RATINGS

IN to GND	-0.3V to +30V	BATT Short-Circuit Duration	Continuous
ABI, BATT, EN, POK, ABO, ABO, CHG, DETBAT, SETI, MIN, SAFEOUT to GND	-0.3V to +6V	Operating Temperature Range	-40°C to +85°C
IN to BATT Continuous Current	1A <sub>RMS</sub>	Junction Temperature	+150°C
Continuous Power Dissipation (T <sub>A</sub> = +70°C)		Storage Temperature Range	-65°C to +150°C
12-Thin QFN (derate 14.7mW/°C above +70°C)		Lead Temperature (soldering, 10s)	+300°C
(multilayer PCB)	1176.5mW		

Stresses beyond those listed under "Absolute Maximum Ratings" may cause permanent damage to the device. These are stress ratings only, and functional operation of the device at these or any other conditions beyond those indicated in the operational sections of the specifications is not implied. Exposure to absolute maximum rating conditions for extended periods may affect device reliability.

## ELECTRICAL CHARACTERISTICS

(V<sub>IN</sub> = 5V, V<sub>BATT</sub> = 4V, R<sub>POK</sub> = 1MΩ to BATT, EN = unconnected, R<sub>SETI</sub> = 2.8kΩ to GND, V<sub>DETBAT</sub> = 0, C<sub>BATT</sub> = 2.2μF, T<sub>A</sub> = -40°C to +85°C, unless otherwise noted. Typical values are at T<sub>A</sub> = +25°C.) (Note 1)

PARAMETER	CONDITIONS		MIN	TYP	MAX	UNITS
Input Supply Voltage Range			0		28	V
Input Supply Operating Voltage Range			4.25		7.00	V
	MAX8845W only		4.40		7.00	
Overvoltage Lockout Trip Threshold	V <sub>IN</sub> rising, 100mV hysteresis (typ)		7.0	7.5	8.0	V
	MAX8845X only		7.5	8.0	8.5	
Input Current	Constant current charging I <sub>IN</sub> - I <sub>BATT</sub> , I <sub>BATT</sub> = 0			0.22	0.50	mA
	Constant current charging I <sub>IN</sub> - I <sub>BATT</sub> , I <sub>BATT</sub> = 500mA			1		
	IC disabled, V <sub>EN</sub> = 5V			0.20	0.50	
	V <sub>IN</sub> = 4V, V <sub>BATT</sub> = 4.2V (4.35V for MAX8845W only)	T <sub>A</sub> = +25°C		0.02		
T <sub>A</sub> = +85°C			0.03			
<b>BATT, CHG, POK</b>						
Minimum BATT Bypass Capacitance				2.2		μF
V <sub>BATT</sub> Prequalification Threshold Voltage	V <sub>BATT</sub> rising, 100mV hysteresis (typ)		2.3	2.5	2.7	V
Battery Regulation Voltage	I <sub>BATT</sub> = 0	T <sub>A</sub> = -40°C to +85°C	4.175	4.200	4.225	V
			4.158	4.200	4.242	
	MAX8845W only		4.324	4.350	4.376	
			4.306	4.350	4.394	
Regulator Dropout Voltage (V <sub>IN</sub> - V <sub>BATT</sub> )	V <sub>BATT</sub> = 4.1V, I <sub>BATT</sub> = 425mA			260		mV
BATT Input Current	V <sub>IN</sub> = 0 to 4V, V <sub>BATT</sub> = 4.2V (4.35V for MAX8845W only)			5	10	μA
	IC disabled			3		
Current-Sense Amplifier Gain (I <sub>BATT</sub> to I <sub>SETI</sub> )	I <sub>BATT</sub> = 500mA			1016		μA/A
Fast-Charge Current	V <sub>BATT</sub> = 3.5V, R <sub>SETI</sub> = 2.8kΩ	T <sub>A</sub> = 0°C to +85°C	460	500	540	mA
		T <sub>A</sub> = -40°C to +85°C	425	500	575	
	V <sub>BATT</sub> = 3.5V, R <sub>SETI</sub> = 14kΩ	T <sub>A</sub> = 0°C to +85°C	85	100	115	
CHG Top-Off Threshold	I <sub>BATT</sub> falling, battery is charged R <sub>MIN</sub> = 1.75kΩ			106		mA

# 28V Linear Li+ Battery Chargers with Battery Detection and Overvoltage Protected Output

## ELECTRICAL CHARACTERISTICS (continued)

( $V_{IN} = 5V$ ,  $V_{BATT} = 4V$ ,  $R_{POK} = 1M\Omega$  to BATT,  $\overline{EN}$  = unconnected,  $R_{SET1} = 2.8k\Omega$  to GND,  $V_{DETBAT} = 0$ ,  $C_{BATT} = 2.2\mu F$ ,  $T_A = -40^\circ C$  to  $+85^\circ C$ , unless otherwise noted. Typical values are at  $T_A = +25^\circ C$ .) (Note 1)

PARAMETER	CONDITIONS	MIN	TYP	MAX	UNITS
$\overline{CHG}$ Hysteresis	$I_{BATT}$ rising after top-off is detected, $R_{MIN} = 1.75k\Omega$		38		mA
$\overline{CHG}$ Detection Delay	$I_{BATT}$ falls below top-off threshold	4.0	6.2	10.7	ms
Prequalification Charge Current	Percentage of the fast-charge current, $V_{BATT} = 2.2V$ , $T_A = 0^\circ C$ to $+85^\circ C$	5	10	15	%
$\overline{CHG}$ , $\overline{POK}$ Output Low Threshold	$I_{POK} = 5mA$ , $I_{CHG} = 5mA$			0.4	V
$\overline{CHG}$ , $\overline{POK}$ Output High Leakage Current	$V_{POK} = 5.5V$ , $V_{CHG} = 5.5V$ , $T_A = +25^\circ C$			1	$\mu A$
	$T_A = +85^\circ C$		0.01		
POK Threshold	$V_{IN} - V_{BATT}$	$V_{IN}$ rising		40	mV
		$V_{IN}$ falling		30	
<b>DETBAT, SAFEOUT</b>					
DETBAT Logic-Input Low Threshold				0.4	V
DETBAT Logic-Input High Threshold		1.3			
DETBAT Pullup Resistor	DETBAT to $V_L = 3V$		470		$k\Omega$
Minimum SAFEOUT Bypass Capacitance			1		$\mu F$
SAFEOUT Regulated Output	$I_{SAFEOUT} = 30mA$ , $V_{IN} = 5V$ , $T_A = 0^\circ C$ to $+85^\circ C$ (MAX8845Z/MAX8845Y/MAX8845W)	4.5	4.7	4.9	V
	$I_{SAFEOUT} = 20mA$ , $V_{IN} = 5V$ , $T_A = 0^\circ C$ to $+85^\circ C$ (MAX8845X)	4.75	4.85	5.0	
SAFEOUT Current Limit			100		mA
<b>EN, ABI, ABO, ABO</b>					
$\overline{EN}$ , ABI Internal Pulldown Resistor		100	200	400	$k\Omega$
$\overline{EN}$ Logic-Input Low Threshold	$4.25V$ (4.4V for MAX8845W only) $\leq V_{IN} \leq 7V$			0.4	V
$\overline{EN}$ Logic-Input High Threshold	$4.25V$ (4.4V for MAX8845W only) $\leq V_{IN} \leq 7V$	1.3			V
ABI Logic-Input Low Threshold	$V_{BATT} = 4V$ , $V_{IN} = 0$			0.4	V
ABI Logic-Input High Threshold	$V_{BATT} = 4V$ , $V_{IN} = 0$	1.3			V
$\overline{ABO}$ Output Low Threshold (MAX8845Y/MAX8845X/MAX8845W)	Open drain, $I_{\overline{ABO}}(SINK) = 1mA$			0.4	V
$\overline{ABO}$ Output High Threshold (MAX8845Y/MAX8845X/MAX8845W)	Open drain, 100 $k\Omega$ pullup to BATT	$V_{BATT} - 0.4V$			V
ABO Output Low Threshold (MAX8845Z)	$I_{ABO}(SINK) = 1mA$			0.4	V
ABO Output High Threshold (MAX8845Z)	$I_{ABO}(SOURCE) = 1mA$	$V_{BATT} - 0.4V$			V
<b>THERMAL</b>					
Die Temperature Regulation Threshold			115		$^\circ C$

**Note 1:** Specifications are 100% production tested at  $T_A = +25^\circ C$ . Limits over the operating temperature range are guaranteed by design and characterization.

# 28V Linear Li+ Battery Chargers with Battery Detection and Overvoltage Protected Output

## Typical Operating Characteristics

( $V_{IN} = 5V$ ,  $V_{BATT} = 4V$ ,  $R_{POK} = R_{CHG} = 200k\Omega$  to 5V,  $\overline{EN} =$  unconnected,  $R_{SET1} = 2.8k\Omega$  to GND,  $R_{MIN} = 1.74k\Omega$  to GND,  $R_{DETBAT} = 4.7k\Omega$  to GND,  $C_{BATT} = 2.2\mu F$ ,  $T_A = +25^\circ C$ , unless otherwise noted.)

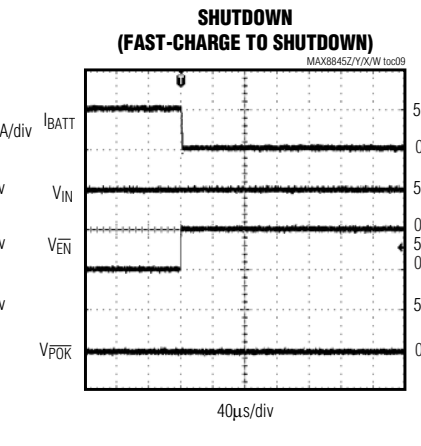
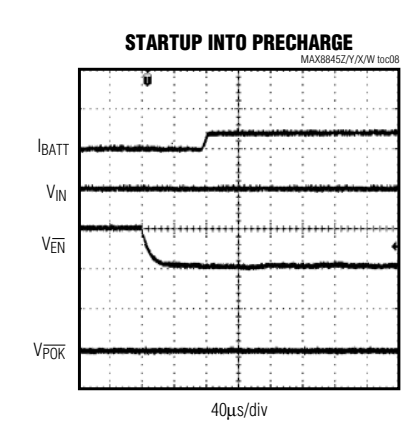
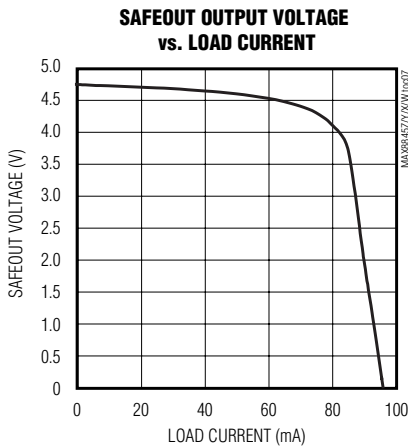
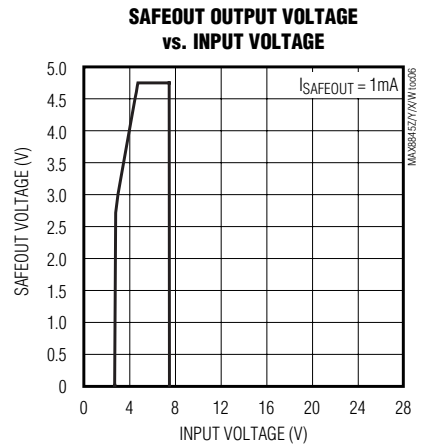
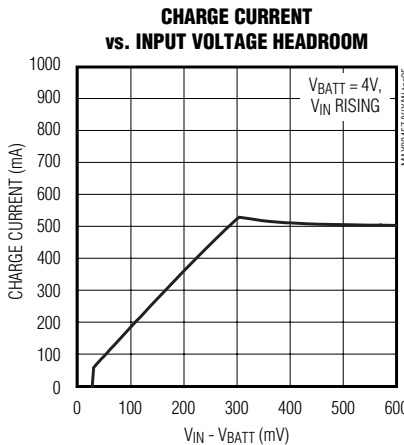
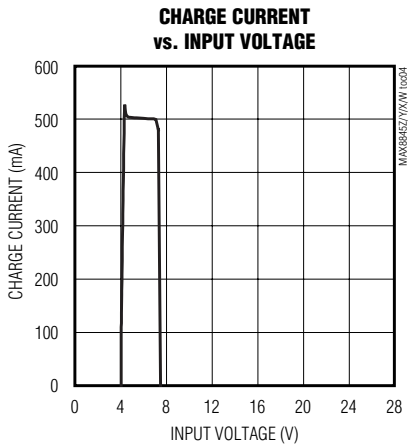
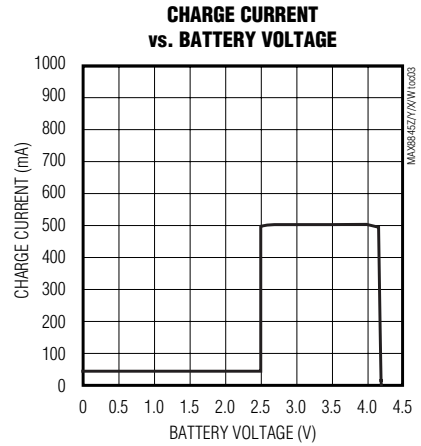
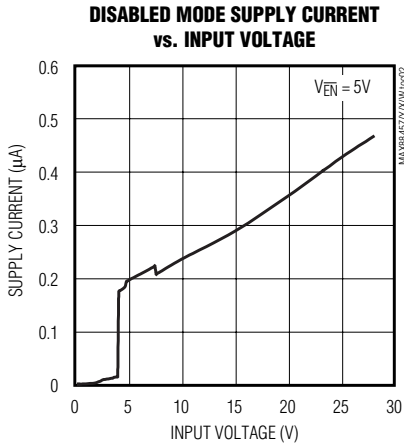
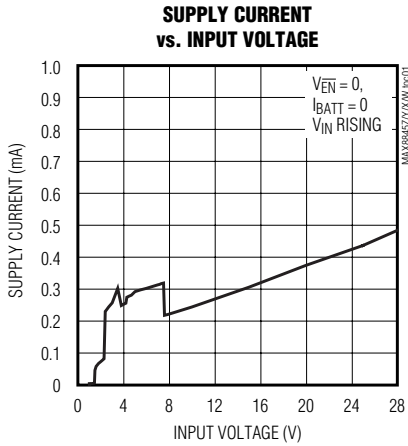

# 28V Linear Li+ Battery Chargers with Battery Detection and Overvoltage Protected Output

## Typical Operating Characteristics (continued)

( $V_{IN} = 5V$ ,  $V_{BATT} = 4V$ ,  $R_{POK} = R_{CHG} = 200k\Omega$  to 5V,  $\overline{EN}$  = unconnected,  $R_{SET1} = 2.8k\Omega$  to GND,  $R_{MIN} = 1.74k\Omega$  to GND,  $R_{DETBAT} = 4.7k\Omega$  to GND,  $C_{BATT} = 2.2\mu F$ ,  $T_A = +25^\circ C$ , unless otherwise noted.)

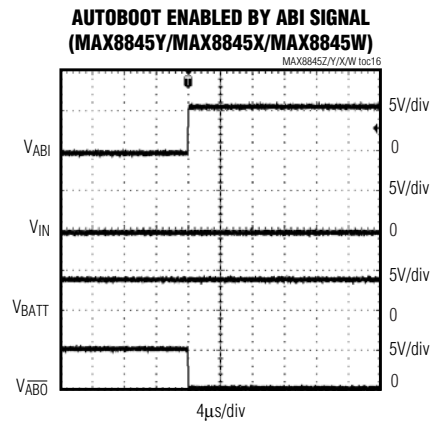
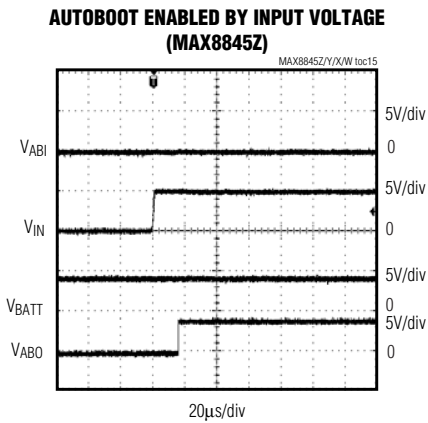
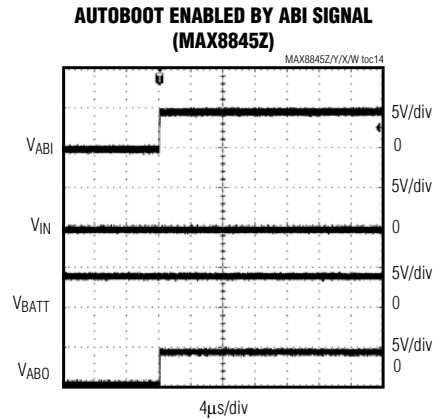
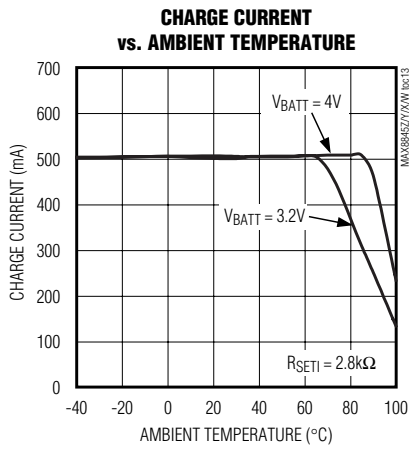
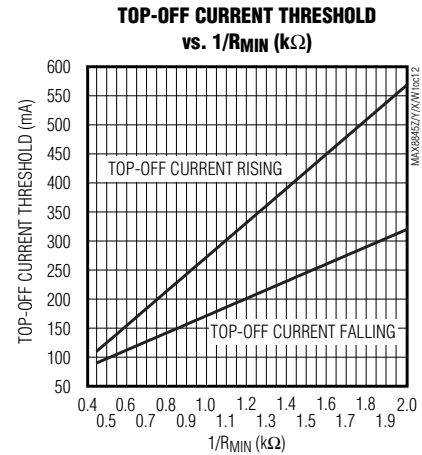
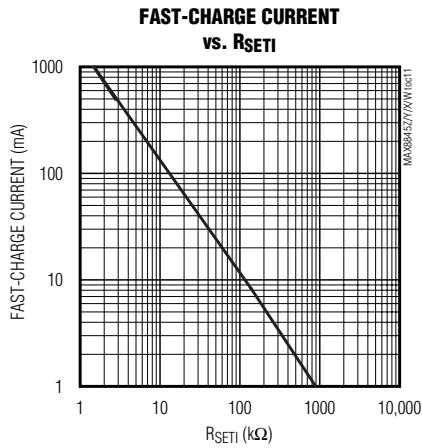
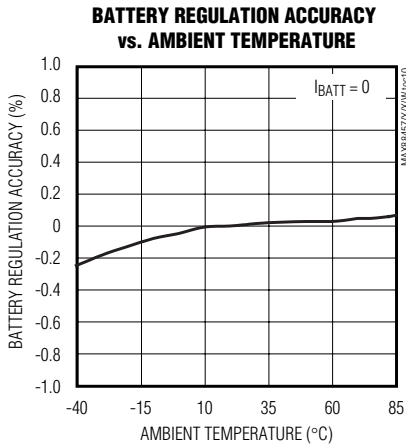

MAX8845Z/MAX8845Y/MAX8845X/MAX8845W



## 28V Linear Li+ Battery Chargers with Battery Detection and Overvoltage Protected Output

### Pin Description

PIN		NAME	FUNCTION
MAX8845Z	MAX8845Y/ MAX8845X/ MAX8845W		
1	1	SETI	Charge-Current Program and Fast-Charge Current Monitor. Output current from SETI is 1016 $\mu$ A per ampere of battery charging current. Set the charging current by connecting a resistor (RSETI in Figure 3) from SETI to GND. IFAST-CHARGE = 1400V/RSETI. To configure the MAX8845Z/MAX8845Y/MAX8845X/MAX8845W as a USB charger, see Figure 5.
2	2	DETBAT	Battery Pack ID Resistor Detection Input. If DETBAT is pulled low through a pulldown resistor less than 51k $\Omega$ the charger is enabled. If DETBAT is left unconnected, the charger is disabled.
3	3	ABI	Autobooting External Input. See the <i>Autobooting Assistant</i> section and Table 1 for autobooting conditions. ABI is pulled to GND through an internal 200k $\Omega$ resistor.
4	4	$\overline{\text{EN}}$	Active-Low, Logic-Level Enable Input. Drive $\overline{\text{EN}}$ high to disable charger. Drive $\overline{\text{EN}}$ low or leave unconnected for normal operation. $\overline{\text{EN}}$ has an internal 200k $\Omega$ pulldown resistor.
5	5	GND	Ground. Connect GND and the exposed pad to a large copper ground plane for maximum power dissipation. Connect GND to the exposed pad directly under the IC.
6	6	$\overline{\text{POK}}$	Active-Low, Input Voltage Status Indicator. $\overline{\text{POK}}$ is an open-drain output that asserts low when 2.35V < VIN < 7V (7.5V for MAX8845X only) and (VIN - VBATT) $\geq$ 40mV. If VIN > +7.5V (+8.0V for MAX8845X only) or VBATT > VIN the IC is shut down and POK becomes high impedance. Connect a pullup resistor to the microprocessor's I/O voltage when interfacing with a microprocessor logic input.
7	—	ABO	Active-High, Autobooting Logic Output. See the <i>Autobooting Assistant</i> section and Table 1 for autobooting conditions.
—	7	$\overline{\text{ABO}}$	Active-Low, Open-Drain Logic Output. See the <i>Autobooting Assistant</i> section and Table 1 for autobooting conditions.
8	8	BATT	Li+ Battery Connection. Bypass BATT to GND with a 2.2 $\mu$ F ceramic capacitor.
9	9	MIN	Top-Off Current Threshold Programmable Input. I <sub>MIN</sub> (mA) falling = 148V/R <sub>MIN</sub> (k $\Omega$ ) + 22 (mA).
10	10	$\overline{\text{CHG}}$	Active-Low, Charging Indicator. $\overline{\text{CHG}}$ is an open-drain output that is pulled low once charging begins. $\overline{\text{CHG}}$ is high impedance when the battery current drops below MIN, or when the IC is disabled. Connect a pullup resistor to the microprocessor's I/O voltage when interfacing with a microprocessor logic input.
11	11	IN	Input Supply Voltage. Bypass IN to GND with a 1 $\mu$ F or larger ceramic capacitor to improve line noise and input transient rejection.
12	12	SAFEOUT	4.7V (MAX8845Z/MAX8845Y/MAX8845W) or 4.85V (MAX8845X) Regulated LDO Output with Input Overvoltage Protection. Bypass SAFEOUT to GND with a 1 $\mu$ F or larger ceramic capacitor. SAFEOUT can be used to supply low voltage-rated USB systems.
—	—	EP	Exposed Pad. Connect the exposed pad to a large ground plane for maximum power dissipation. Connect GND to the exposed pad directly under the IC.

## 28V Linear Li+ Battery Chargers with Battery Detection and Overvoltage Protected Output

MAX8845Z/MAX8845Y/MAX8845X/MAX8845W

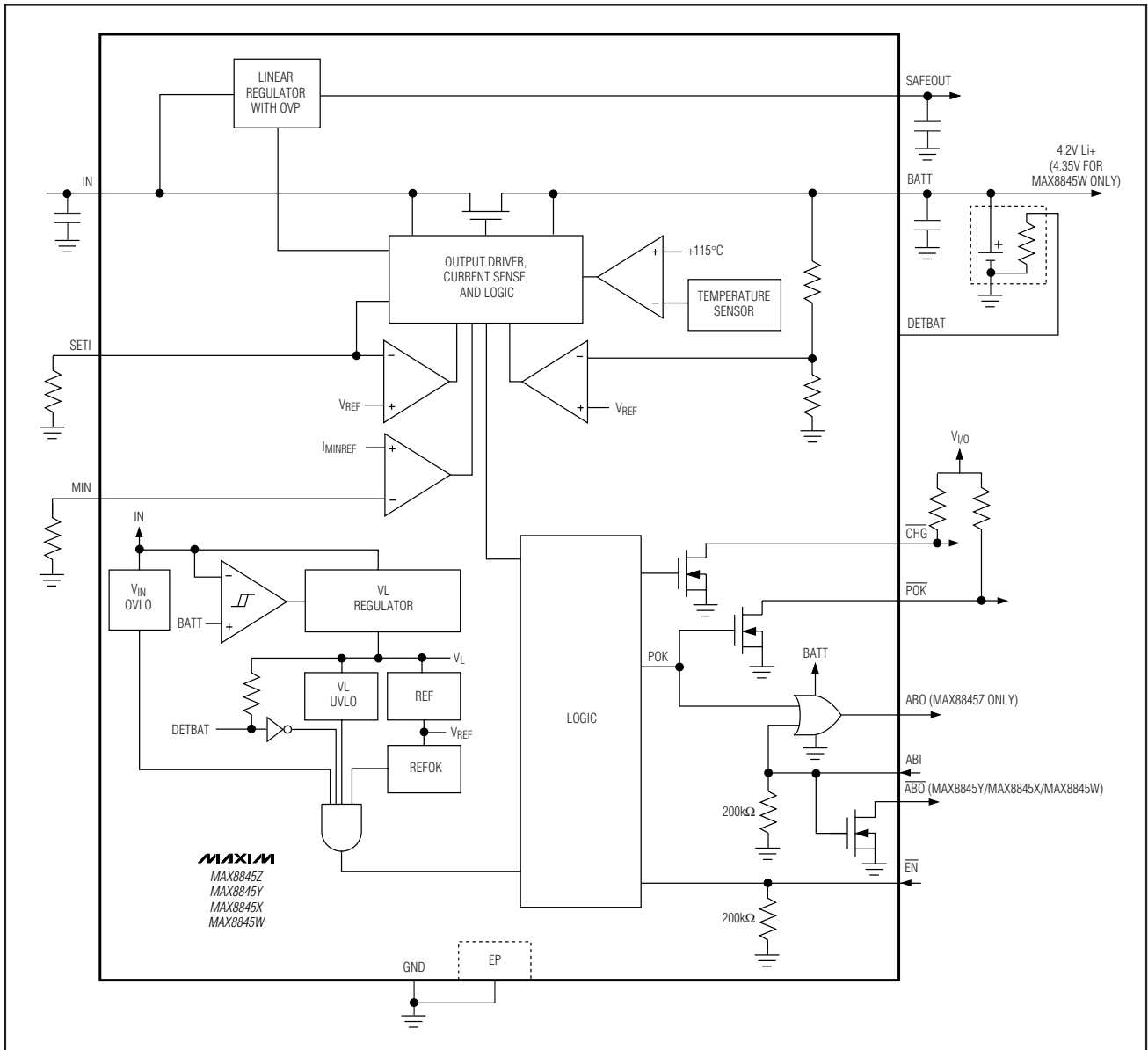

Figure 1. MAX8845Z/MAX8845Y/MAX8845X/MAX8845W Functional Diagram

### Detailed Description

The MAX8845Z/MAX8845Y/MAX8845X/MAX8845W chargers use voltage, current, and thermal-control loops to charge a single Li+ cell and protect the battery (Figure 1). When a Li+ battery with a cell voltage below 2.5V is inserted, the MAX8845Z/MAX8845Y/MAX8845X/MAX8845W chargers enter a prequalification stage where it precharges that cell with 10% of the user-pro-

grammed fast-charge current (Figure 2). The  $\overline{\text{CHG}}$  indicator is driven low to indicate entry into the prequalification state. When the battery voltage exceeds 2.5V, the charger soft-starts as it enters the fast-charge stage. The fast-charge current level is programmed through a resistor from SET1 to GND. As the battery voltage approaches 4.2V, the charging current is reduced. If the battery current drops to less than the



## 28V Linear Li+ Battery Chargers with Battery Detection and Overvoltage Protected Output

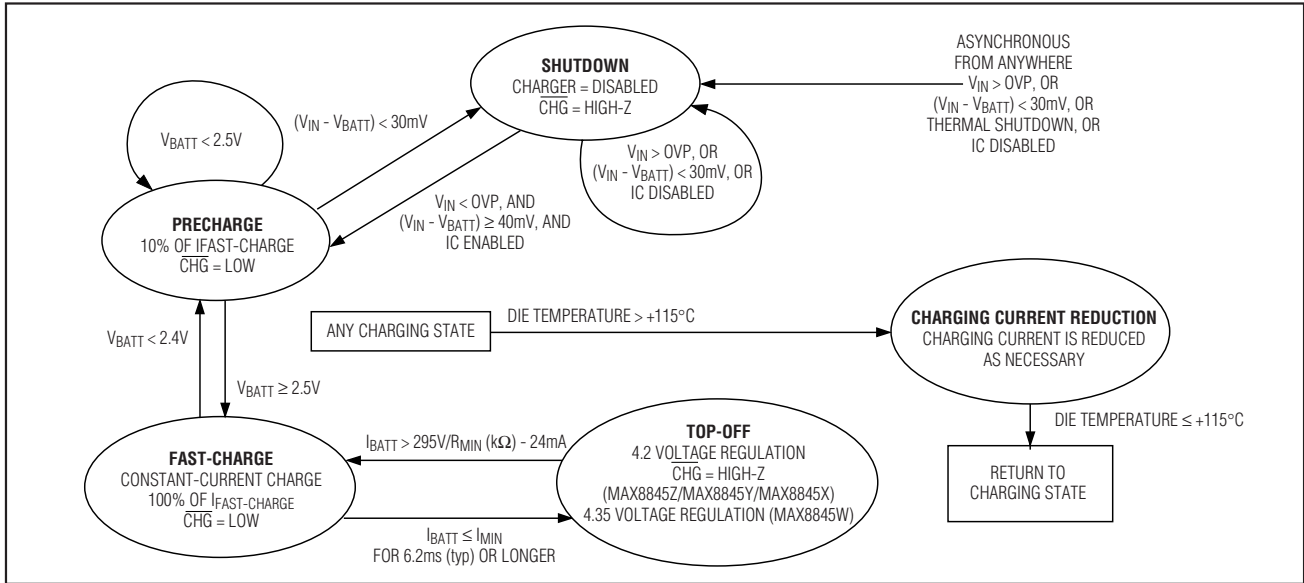

Figure 2. Charge-State Diagram

top-off current threshold set by  $R_{MIN}$ , the charger enters top-off mode and the  $\overline{CHG}$  indicator goes high impedance signaling that the battery is fully charged.

### Overvoltage-Protected Output (SAFEOUT)

SAFEOUT is a linear regulator that provides an output voltage of 4.7V (MAX8845Z/MAX8845Y/MAX8845W) or 4.85V (MAX8845X) and can be used to supply low voltage-rated USB systems. The SAFEOUT linear regulator turns on when  $V_{IN} \geq 4.25V$  regardless of  $\overline{EN}$  and is disabled when  $V_{IN}$  is greater than the overvoltage threshold (7.5V typ) (8.0V typ for MAX8845X only).

### Battery-Pack Detection Input (DETBAT)

DETBAT is a battery-pack ID resistor detector that enables the battery charger if pulled low through a resistor that is less than 51k $\Omega$ . If DETBAT is left unconnected or the pulldown resistor is 51k $\Omega$  or greater the battery charger is disabled. If DETBAT is not used connect DETBAT to GND for normal operation.

### $\overline{POK}$ Output

The open-drain  $\overline{POK}$  output asserts low when  $2.35V \leq V_{IN} \leq 7V$  (7.5V for MAX8845X only) and  $(V_{IN} - V_{BATT}) \geq 40mV$  (typ  $V_{IN}$  rising).  $\overline{POK}$  is high impedance during shutdown. When interfacing with a microprocessor logic input, a pullup resistor to the microprocessor's I/O voltage may be required.

### Autobooting Assistant

The MAX8845Z/MAX8845Y/MAX8845X/MAX8845W contain autobooting assistant circuits that generate an enable signal for system booting ( $\overline{ABO}$ —MAX8845Z,  $\overline{ABO}$ —MAX8845Y/MAX8845X/MAX8845W). For the MAX8845Z, the booting assistant functions as an internal OR gate (Figure 1). The first input is dependant on the input voltage ( $V_{IN}$ ) and DETBAT while the second input is an external signal applied to ABI. The first input ( $\overline{POK}$ ) is driven high once DETBAT is pulled low through a resistor less than 51k $\Omega$ ,  $2.35V \leq V_{IN} \leq 7V$  (7.5V for only MAX8845X), and  $(V_{IN} - V_{BATT}) \geq 40mV$  (typ  $V_{IN}$  rising).

The second input signal (ABI) is driven by an external source (Table 1). ABI enables an autoboot signal when a battery is connected at BATT and is independent of  $\overline{POK}$ . If  $\overline{POK}$  is pulled low, the booting assistant always drives  $\overline{ABO}$  high regardless of ABI. ABI is pulled to GND through an internal 200k $\Omega$  resistor. If ABI is supplied from an outside exposed pin, a RC filter (Figure 4) is required for ESD protection and noise filtering. If ABI is supplied by a system's internal GPIO, or logic, the RC filter is not required. For the MAX8845Y/MAX8845X/MAX8845W, the output  $\overline{ABO}$  is only dependent on the state of ABI (Table 1).

### $\overline{CHG}$ Charge Indicator Output

$\overline{CHG}$  is an open-drain output that indicates charge status. Table 2 describes the state of  $\overline{CHG}$  during different stages of operation.  $\overline{CHG}$  is suitable for driving a charge indication LED. If the MAX8845Z/MAX8845Y/MAX8845X/

# 28V Linear Li+ Battery Chargers with Battery Detection and Overvoltage Protected Output

**Table 1. Autobooting Output States**

ABI	BATT	$\overline{\text{POK}}$	CHARGER STATE	ABO (MAX8845Z)	$\overline{\text{ABO}}$ (MAX8845Y/MAX8845X/MAX8845W)
Low	Present	High-Z	Shutdown	Low	High-Z
High	Present	High-Z	Shutdown	High	Low
Low	Not present	Low	CC/CV mode	High	High-Z
Low	Present	Low	Fast-charge/top-off	High	High-Z
High	Present	Low	Fast-charge/top-off	High	Low

**Note:** Present indicates that  $V_{\text{BATT}} \geq 2\text{V}$  and Not Present indicates that the battery is not connected.

**Table 2. CHG States**

$\overline{\text{EN}}$	$V_{\text{IN}}$	$V_{\text{BATT}}$	$I_{\text{BATT}}$	CHG	STATE
High	X	X	0	High-Z	Disabled
Low	$> 7.5\text{V}$	X	0	High-Z	Shutdown
	X	$> V_{\text{IN}} - 30\text{mV}$			
Low	$4.25\text{V (4.4V for MAX8845W only)} \leq V_{\text{IN}} \leq 7.5\text{V}$	$< 2.4\text{V}$	10% of $I_{\text{FAST-CHARGE}}^*$	Low	Precharge
Low	$4.25\text{V (4.4V for MAX8845W only)} \leq V_{\text{IN}} \leq 7.5\text{V}$	$\geq 2.5\text{V}$	100% of $I_{\text{FAST-CHARGE}}^*$	Low	Fast-charge
Low	$4.25\text{V (4.4V for MAX8845W only)} \leq V_{\text{IN}} \leq 7.5\text{V}$	$4.2\text{V (4.35V for MAX8845W only)}$	$< I_{\text{MIN}}$	High-Z	Top-off

X = Don't care.

\* $I_{\text{FAST-CHARGE}}$  is reduced as necessary to prevent the die temperature from exceeding  $+115^\circ\text{C}$ .

MAX8845W are used in conjunction with a microprocessor, a pullup resistor to the logic I/O voltage allows CHG to indicate charge status to the microprocessor instead of driving an LED.

### Thermal Regulation

The thermal-regulation loop limits the MAX8845Z/MAX8845Y/MAX8845X/MAX8845W die temperature to  $+115^\circ\text{C}$  by reducing the charge current as necessary. This feature not only protects the IC from overheating, but also allows a higher charge current without risking damage to the system.

### Charger Enable Input

The MAX8845Z/MAX8845Y/MAX8845X/MAX8845W contain active-low logic input ( $\overline{\text{EN}}$ ) used to enable the chargers. Drive  $\overline{\text{EN}}$  low, leave unconnected, or connect to GND to enable the charge-control circuitry. Drive  $\overline{\text{EN}}$  high to disable the charger-control circuitry.  $\overline{\text{EN}}$  has an internal  $200\text{k}\Omega$  pulldown resistor.

### Soft-Start

The soft-start algorithm activates when entering fast-charge mode. When the prequalification state is complete ( $V_{\text{BATT}}$  exceeds  $+2.5\text{V}$ ), the charging current ramps up in  $250\mu\text{s}$  to the full charging current. This reduces the inrush current demand on the input supply.

## Applications Information

### Fast Charge-Current Setting

The maximum charging current is programmed by an external resistor connected from SET1 to GND ( $R_{\text{SET1}}$ ). Use the following equation to determine the fast-charge current ( $I_{\text{FAST\_CHARGE}}$ ):

$$I_{\text{FAST\_CHARGE}} = \frac{1400\text{V}}{R_{\text{SET1}}}$$

where  $I_{\text{FAST\_CHARGE}}$  is in amps and  $R_{\text{SET1}}$  is in ohms.  $R_{\text{SET1}}$  must always be  $1.4\text{k}\Omega$  or higher due to the continuous charging current limit of  $1\text{A}_{\text{RMS}}$ .

### Top-Off Current Threshold Setting

The top-off current threshold is programmed by an external resistor connected from MIN to GND ( $R_{\text{MIN}}$ ). Use the following equation to determine the top-off current ( $I_{\text{MIN}}$ ):

$$I_{\text{MIN}} (\text{falling}) = 148\text{V}/R_{\text{MIN}} (\text{k}\Omega) + 22\text{mA}$$

$$I_{\text{MIN}} (\text{rising}) = 295\text{V}/R_{\text{MIN}} (\text{k}\Omega) - 24\text{mA}$$

where  $I_{\text{MIN}}$  is in mA and  $R_{\text{MIN}}$  is in  $\text{k}\Omega$ . Use  $R_{\text{MIN}} \leq 2.2\text{k}\Omega$ .

## 28V Linear Li+ Battery Chargers with Battery Detection and Overvoltage Protected Output

### Capacitor Selection

Connect a ceramic capacitor from BATT to GND for proper stability. Use a 2.2 $\mu$ F ceramic capacitor for most applications. Connect a 1 $\mu$ F ceramic capacitor from IN to GND. A larger input capacitor can be used for high charging current to reduce input voltage ripple.

Connect a 1 $\mu$ F ceramic capacitor from SAFEOUT to GND. A larger bypass capacitor for SAFEOUT can be used for optimum noise immunity. Ceramic capacitors with X5R or X7R dielectric are highly recommended due to their small size, low ESR, and small temperature coefficients.

### Thermal Considerations

The MAX8845Z/MAX8845Y/MAX8845X/MAX8845W are available in thermally enhanced Thin QFN packages with exposed pads. Connect the exposed pad to a large copper ground plane to provide a thermal contact between the device and the circuit board for increased power dissipation. The exposed pad transfers heat away from the device, allowing the IC to charge the battery with maximum current, while minimizing the increase in die temperature.

### DC Input Sources

The MAX8845Z/MAX8845Y/MAX8845X/MAX8845W operate from well-regulated DC sources. The full charging input voltage range is 4.25V (4.4V for MAX8845W only) to 7.5V (8V for MAX8845X only). The device can withstand up to 28V on the input without damage to the IC. If  $V_{IN}$  is greater than 7.5V (8V for MAX8845X only), the internal overvoltage-protection circuitry disables charging until the input falls below 7.5V (8V for MAX8845X only). An appropriate power supply must provide at least 4.25V at the desired peak charging current and stay below 7V when unloaded.

### Typical Application Circuits

#### AC Adapter Application

Figure 3 shows the MAX8845Z as a Li+ battery charger with an AC adapter. The MAX8845Z detects the presence of an input supply and DETBET, resulting in  $\overline{POK}$  pulled low. Once  $\overline{POK}$  is pulled low, the autobooting assistant drives ABO high (MAX8845Z) and enables the power

supplies of the system to boot up. The MAX8845Z begins charging the battery when  $\overline{EN}$  is low or unconnected. By monitoring  $\overline{CHG}$ , the system can detect the top-off threshold and terminate the charge through  $\overline{EN}$ . The MAX8845Z/MAX8845Y/MAX8845X/MAX8845W also provide an overvoltage-protected SAFEOUT to the system.

#### Factory System Interface Connector Application

Figure 4 shows the MAX8845Z as an autoboot assistor with the factory system interface connector. The MAX8845Z detects the ABI input even though there is no input voltage available and generates an ABO signal to turn on power supplies to boot up the system. The configuration in Figure 4 is used for system development, testing, and calibrations in production or design stage.

#### USB-Powered Li-Ion Charger

The universal serial bus (USB) provides a high-speed serial communication port as well as power for the remote device. The MAX8845Z/MAX8845Y/MAX8845X/MAX8845W can be configured to charge batteries at the highest current possible from the host port. Figure 5 shows the MAX8845Z as a USB battery charger. To make the circuit compatible with either 100mA or 500mA USB ports, the circuit initializes at 100mA charging current. The microprocessor then enumerates the host to determine its current capability. If the host port is capable, the charging current is increased to 450mA to avoid exceeding the 500mA USB specification through GPIO control. The MAX8845Z/MAX8845Y/MAX8845X/MAX8845W also provide an overvoltage-protected SAFEOUT to the system.

#### Recommended PCB Layout and Routing

Place all bypass capacitors for IN, BATT, and SAFEOUT as close as possible to the device. Connect the battery to BATT as close as possible to the device to provide accurate battery voltage sensing. Provide a large copper ground plane to allow the exposed pad to sink heat away from the device. Make all high-current traces short and wide to minimize voltage drops. A sample layout is available in the MAX8845Z Evaluation Kit to speed designs.

## 28V Linear Li+ Battery Chargers with Battery Detection and Overvoltage Protected Output

MAX8845Z/MAX8845Y/MAX8845X/MAX8845W

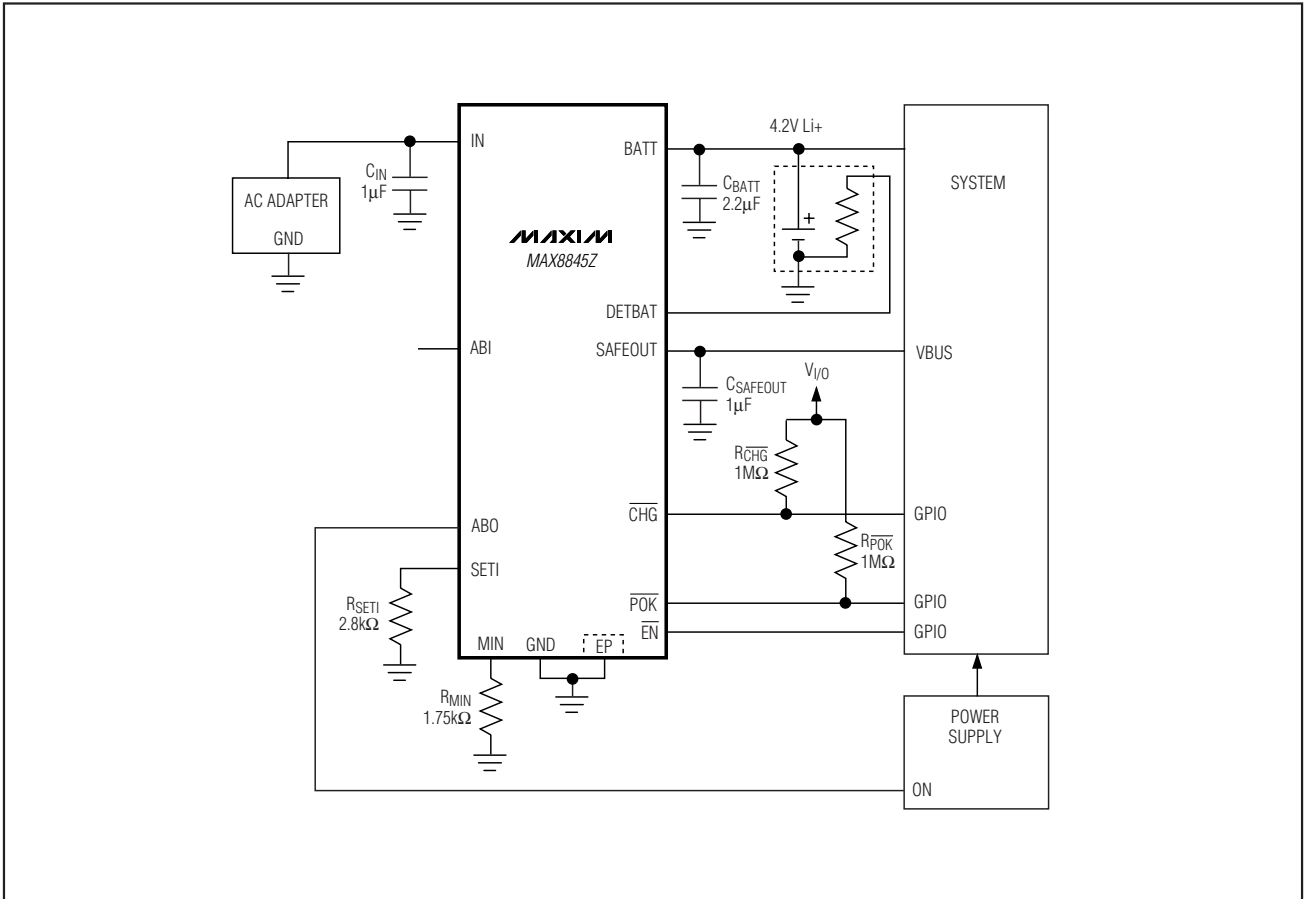

Figure 3. AC Adapter Application

## 28V Linear Li+ Battery Chargers with Battery Detection and Overvoltage Protected Output

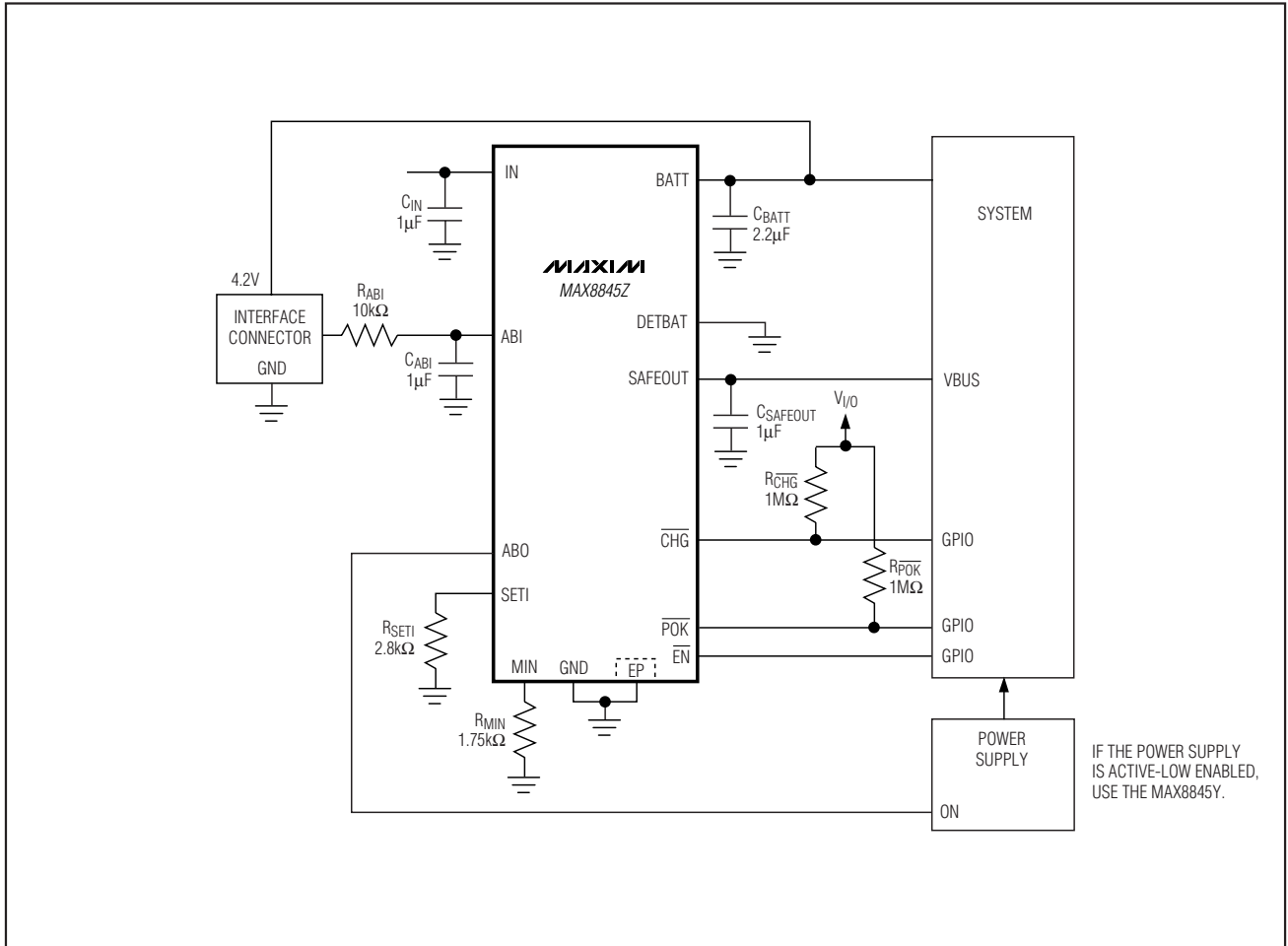

Figure 4. Factory System Interface Connector Application

## 28V Linear Li+ Battery Chargers with Battery Detection and Overvoltage Protected Output

MAX8845Z/MAX8845Y/MAX8845X/MAX8845W

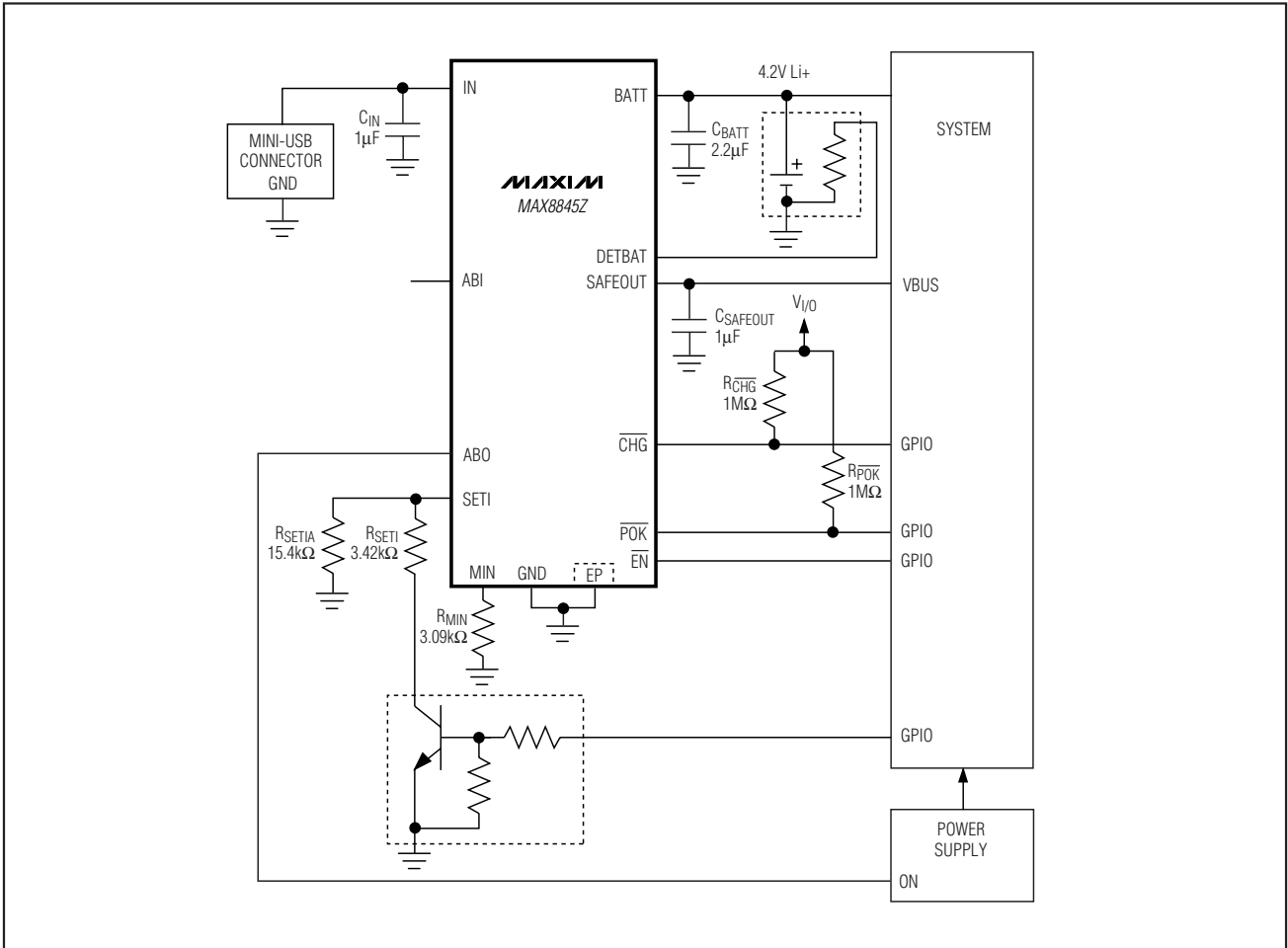

Figure 5. Mini USB Battery Charger

## 28V Linear Li+ Battery Chargers with Battery Detection and Overvoltage Protected Output

MAX8845Z/MAX8845Y/MAX8845X/MAX8845W

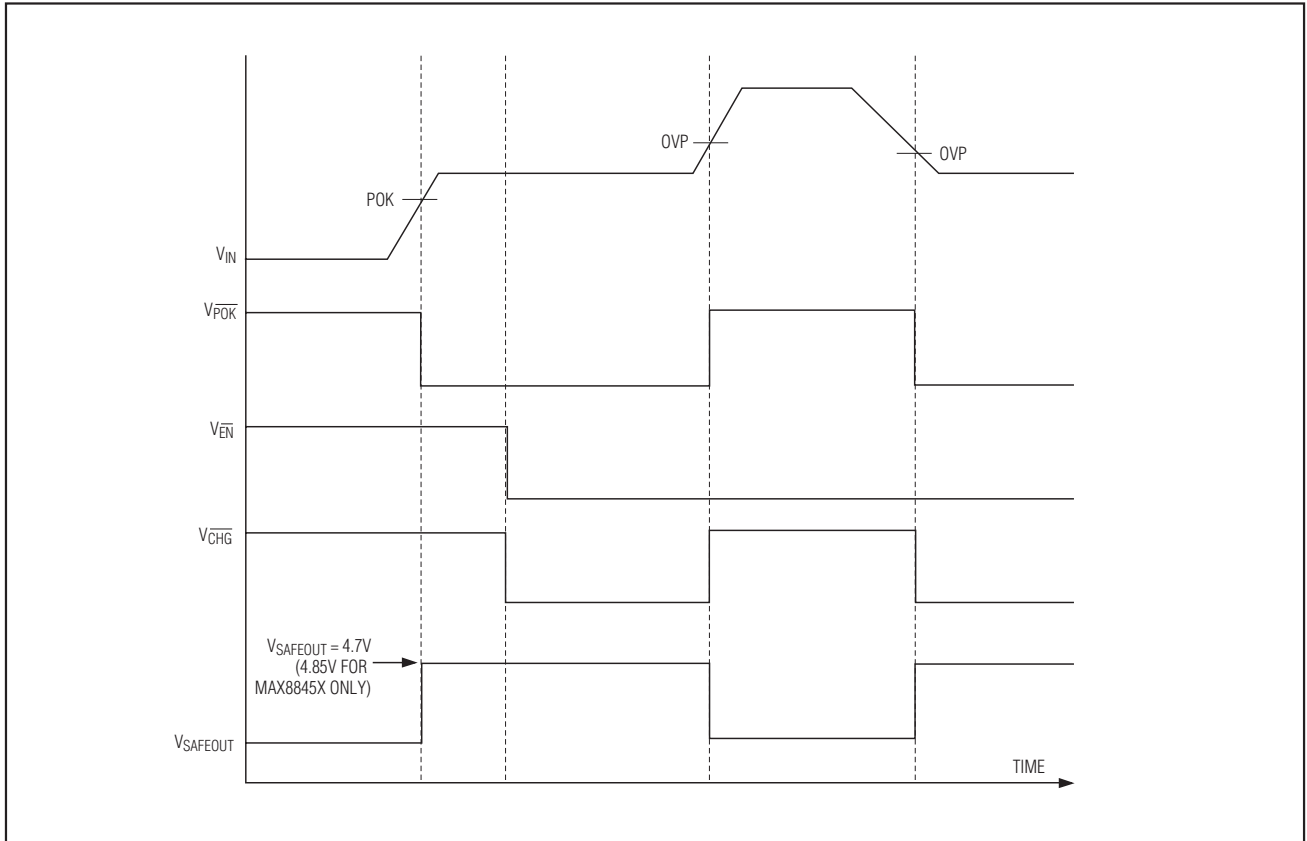
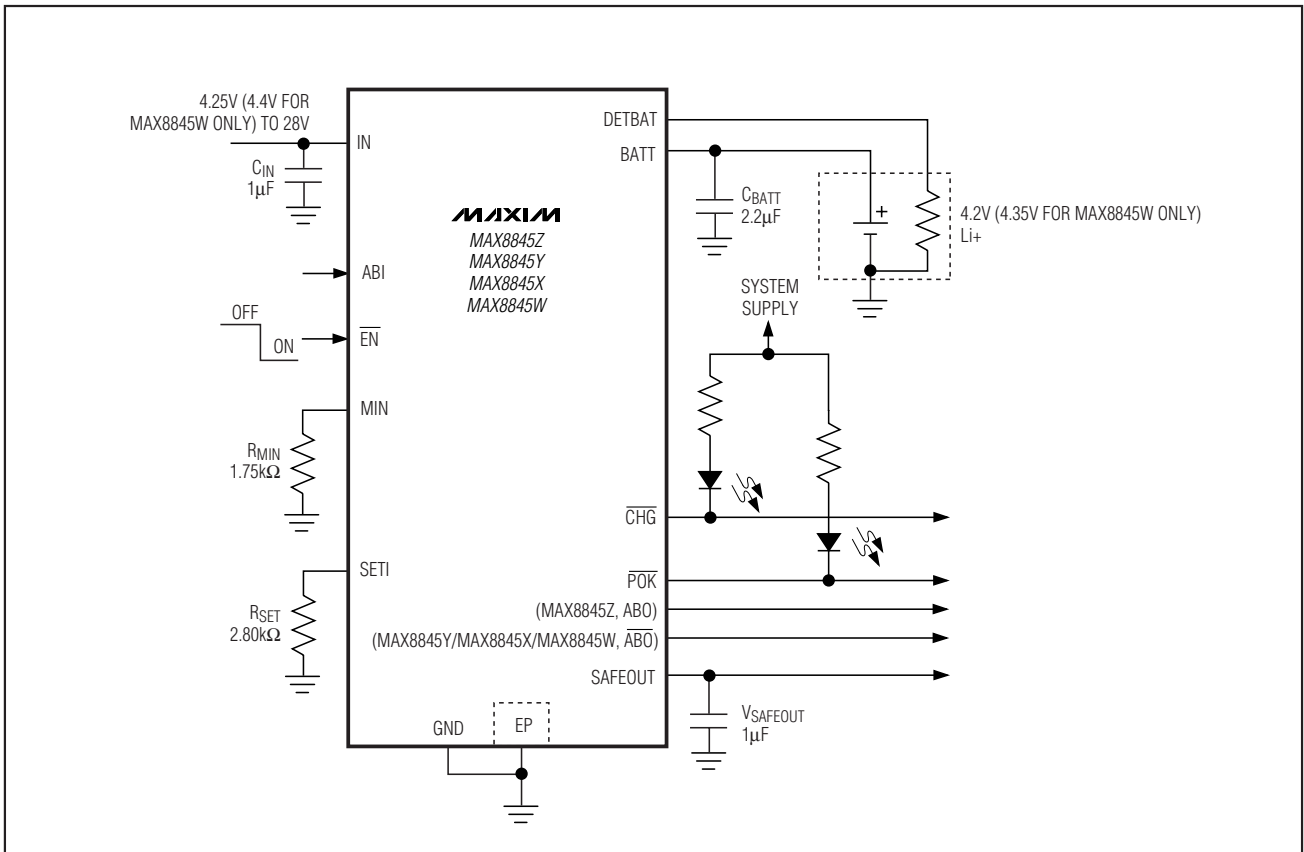

Figure 6. Timing Diagram



# 28V Linear Li+ Battery Chargers with Battery Detection and Overvoltage Protected Output

Typical Operating Circuit



MAX8845Z/MAX8845Y/MAX8845X/MAX8845W

# 28V Linear Li+ Battery Chargers with Battery Detection and Overvoltage Protected Output

## Pin Configurations

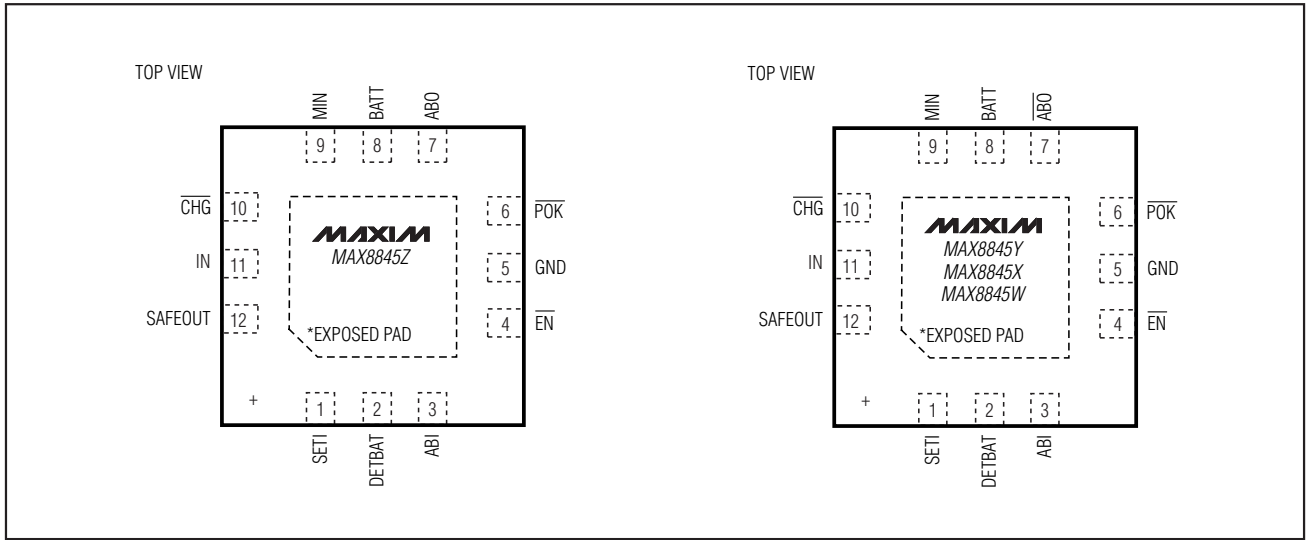

## Chip Information

PROCESS: BiCMOS

# 28V Linear Li+ Battery Chargers with Battery Detection and Overvoltage Protected Output

## Package Information

For the latest package outline information and land patterns, go to [www.maxim-ic.com/packages](http://www.maxim-ic.com/packages).

PACKAGE TYPE	PACKAGE CODE	DOCUMENT NO.
12 Thin QFN-EP (3mm x 3mm)	T1233-4	—

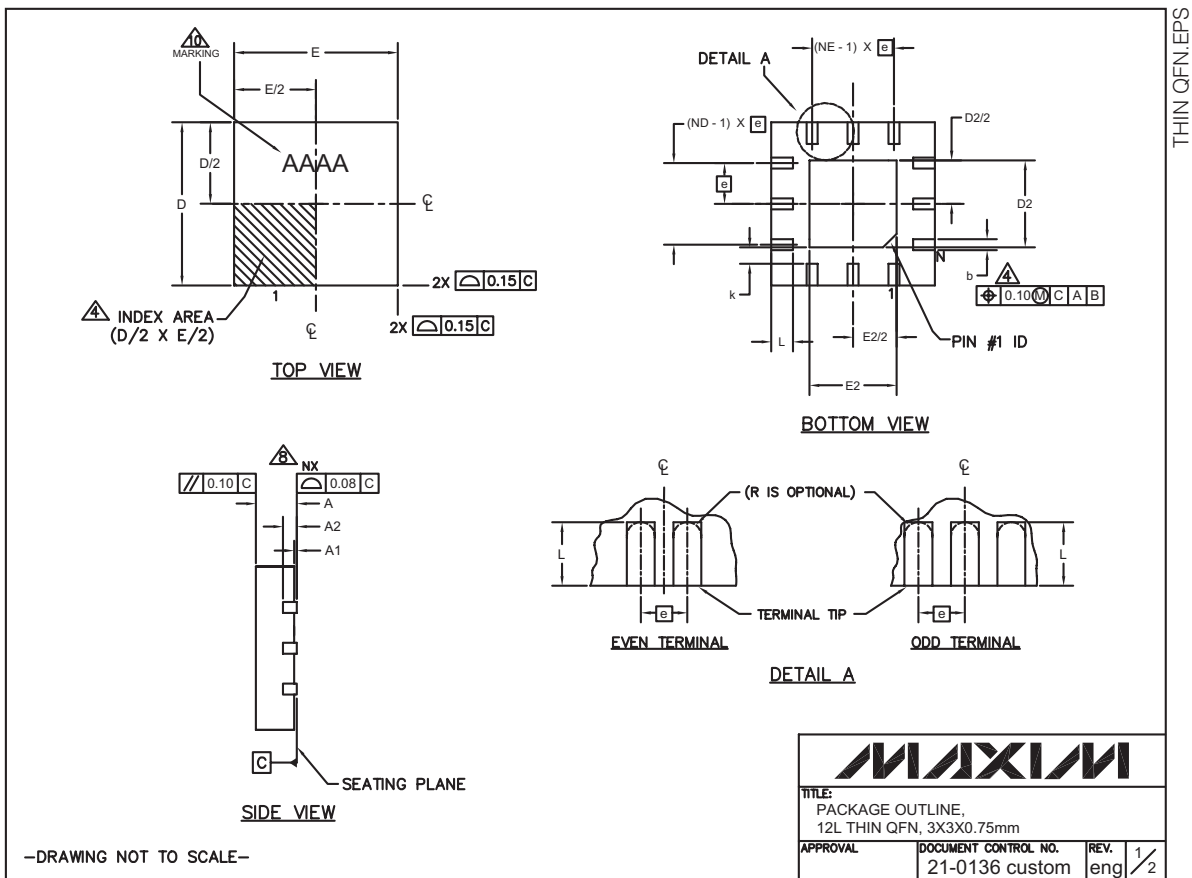

MAX8845Z/MAX8845Y/MAX8845X/MAX8845W

# 28V Linear Li+ Battery Chargers with Battery Detection and Overvoltage Protected Output

## Package Information (continued)

For the latest package outline information and land patterns, go to [www.maxim-ic.com/packages](http://www.maxim-ic.com/packages).

PKG	12L 3x3		
REF.	MIN.	NOM.	MAX.
A	0.70	0.75	0.80
b	0.20	0.25	0.30
D	2.90	3.00	3.10
E	2.90	3.00	3.10
e	0.50 BSC.		
L	0.45	0.55	0.65
N	12		
ND	3		
NE	3		
A1	0	0.02	0.05
A2	0.20 REF		
k	0.25	-	-

PKG. CODES	EXPOSED PAD VARIATIONS						PIN ID	JEDEC
	D2			E2				
	MIN.	NOM.	MAX.	MIN.	NOM.	MAX.		
T1233-1	0.95	1.10	1.25	0.95	1.10	1.25	0.35 x 45°	WEED-1
T1233-3	0.95	1.10	1.25	0.95	1.10	1.25	0.35 x 45°	WEED-1
T1233-4	0.95	1.10	1.25	0.95	1.10	1.25	0.35 x 45°	WEED-1

NOTES:

1. DIMENSIONING & TOLERANCING CONFORM TO ASME Y14.5M-1994.
2. ALL DIMENSIONS ARE IN MILLIMETERS. ANGLES ARE IN DEGREES.
3. N IS THE TOTAL NUMBER OF TERMINALS.
4. THE TERMINAL #1 IDENTIFIER AND TERMINAL NUMBERING CONVENTION SHALL CONFORM TO JESD 95-1 SPP-012. DETAILS OF TERMINAL #1 IDENTIFIER ARE OPTIONAL, BUT MUST BE LOCATED WITHIN THE ZONE INDICATED. THE TERMINAL #1 IDENTIFIER MAY BE EITHER A MOLD OR MARKED FEATURE.
5. DIMENSION b APPLIES TO METALLIZED TERMINAL AND IS MEASURED BETWEEN 0.20 mm AND 0.25 mm FROM TERMINAL TIP.
6. ND AND NE REFER TO THE NUMBER OF TERMINALS ON EACH D AND E SIDE RESPECTIVELY.
7. DEPOPULATION IS POSSIBLE IN A SYMMETRICAL FASHION.
8. COPLANARITY APPLIES TO THE EXPOSED HEAT SINK SLUG AS WELL AS THE TERMINALS.
9. DRAWING CONFORMS TO JEDEC MO220 REVISION C.
10. MARKING IS FOR PACKAGE ORIENTATION REFERENCE ONLY.
11. NUMBER OF LEADS SHOWN ARE FOR REFERENCE ONLY.
12. WARPAGE NOT TO EXCEED 0.10mm.

—DRAWING NOT TO SCALE—

		
TITLE: PACKAGE OUTLINE, 12L THIN QFN, 3X3X0.75mm		
APPROVAL	DOCUMENT CONTROL NO. 21-0136 custom	REV. eng 2/2

# 28V Linear Li+ Battery Chargers with Battery Detection and Overvoltage Protected Output

## Revision History

REVISION NUMBER	REVISION DATE	DESCRIPTION	PAGES CHANGED
0	3/09	Initial release	—
1	9/09	Corrected the $\overline{POK}$ Output section description and added MAX8845X and MAX8845W to data sheet	1-19

MAX8845Z/MAX8845Y/MAX8845X/MAX8845W

Maxim cannot assume responsibility for use of any circuitry other than circuitry entirely embodied in a Maxim product. No circuit patent licenses are implied. Maxim reserves the right to change the circuitry and specifications without notice at any time.

Maxim Integrated Products, 120 San Gabriel Drive, Sunnyvale, CA 94086 408-737-7600 \_\_\_\_\_ 19