

Excellent Integrated System Limited

Stocking Distributor

Click to view price, real time Inventory, Delivery & Lifecycle Information:

[IXYS Corporation](#)
[IXGR12N60C](#)

For any questions, you can email us directly:
sales@integrated-circuit.com

IXYS

HiPerFAST™ IGBT ISOPLUS247™

IXGR 12N60C

(Electrically Isolated Back Surface)

$V_{CES} = 600 \text{ V}$
 $I_{C25} = 15 \text{ A}$
 $V_{CE(sat)} = 2.7 \text{ V}$
 $t_{fi(typ)} = 55 \text{ ns}$

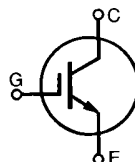

Symbol	Test Conditions	Maximum Ratings	
V_{CES}	$T_J = 25^\circ\text{C to } 150^\circ\text{C}$	600	V
V_{CGR}	$T_J = 25^\circ\text{C to } 150^\circ\text{C}; R_{GE} = 1 \text{ M}\Omega$	600	V
V_{GES}	Continuous	± 20	V
V_{GEM}	Transient	± 30	V
I_{C25}	$T_C = 25^\circ\text{C}$	15	A
I_{C90}	$T_C = 90^\circ\text{C}$	8	A
I_{CM}	$T_C = 25^\circ\text{C}, 1 \text{ ms}$	48	A
SSOA (RBSOA)	$V_{GE} = 15 \text{ V}, T_{VJ} = 125^\circ\text{C}, R_G = 33 \Omega$ Clamped inductive load, $L = 300 \mu\text{H}$	$I_{CM} = 24$ @ $0.8 V_{CES}$	A
P_C	$T_C = 25^\circ\text{C}$	55	W
T_J		-40 ... +150	$^\circ\text{C}$
T_{JM}		150	$^\circ\text{C}$
T_{stg}		-40 ... +150	$^\circ\text{C}$
V_{ISOL}	Isolation Voltage	2500	V
Weight		5	g
Maximum lead temperature for soldering 1.6 mm (0.062 in.) from case for 10 s		300	$^\circ\text{C}$

ISOPLUS 247

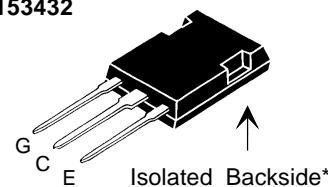

G = Gate C = Drain
E = Source

* Patent pending

Features

- Silicon chip on Direct-Copper-Bond substrate
- High power dissipation
- Isolated mounting surface
- 2500V electrical isolation
- Low collector to tab capacitance (<35pF)
- 3rd generation HDMOS™ process
- $V_{CE(sat)}$
- Rugged polysilicon gate cell structure

Applications

- PFC circuits
- AC motor control
- Switched-mode and resonant-mode power supplies, UPS, no screws, or isolation foils
- DC choppers

Advantages

- Easy assembly
- Low capacitance to ground, low EMI

Symbol	Test Conditions	Characteristic Values ($T_J = 25^\circ\text{C}$, unless otherwise specified)		
		min.	typ.	max.
BV_{CES}	$I_C = 250 \mu\text{A}, V_{GE} = 0 \text{ V}$	600		V
$V_{GE(th)}$	$I_C = 250 \mu\text{A}, V_{GE} = V_{GE}$	2.5		5.0 V
I_{CES}	$V_{CE} = 0.8 V_{CES}$ $V_{GE} = 0 \text{ V}$	$T_J = 25^\circ\text{C}$ $T_J = 125^\circ\text{C}$		200 μA 1.5 mA
I_{GES}	$V_{CE} = 0 \text{ V}, V_{GE} = \pm 20 \text{ V}$			$\pm 100 \text{ nA}$
$V_{CE(sat)}$	$I_C = I_T, V_{GE} = 15 \text{ V}$			2.7 V

Symbol	Test Conditions	Characteristic Values ($T_J = 25^\circ\text{C}$, unless otherwise specified)		
		min.	typ.	max.
g_{fs}	$I_C = I_T, V_{CE} = 10\text{ V}$, Pulse test, $t \leq 300\ \mu\text{s}$, duty cycle $\leq 2\%$	7	11	S
C_{ies}	$V_{CE} = 25\text{ V}, V_{GE} = 0\text{ V}, f = 1\text{ MHz}$		860	pF
C_{oes}			64	pF
C_{res}			15	pF
Q_g	$I_C = I_T, V_{GE} = 15\text{ V}, V_{CE} = 0.5 V_{CES}$		32	nC
Q_{ge}			10	nC
Q_{gc}			10	nC
$t_{d(on)}$	Inductive load, $T_J = 25^\circ\text{C}$ $I_C = I_T, V_{GE} = 15\text{ V}, L = 300\ \mu\text{H}$ $V_{CE} = 0.8 V_{CES}, R_G = R_{off} = 18\ \Omega$ Remarks: Switching times may increase for V_{CE} (Clamp) $> 0.8 V_{CES}$, higher T_J or increased R_G		20	ns
t_{ri}			20	ns
$t_{d(off)}$			60	ns
t_{fi}			55	ns
E_{off}			0.09	mJ
$t_{d(on)}$	Inductive load, $T_J = 125^\circ\text{C}$ $I_C = I_T, V_{GE} = 15\text{ V}, L = 300\ \mu\text{H}$ $V_{CE} = 0.8 V_{CES}, R_G = R_{off} = 18\ \Omega$ Remarks: Switching times may increase for V_{CE} (Clamp) $> 0.8 V_{CES}$, higher T_J or increased R_G		20	ns
t_{ri}			20	ns
E_{on}			0.15	mJ
$t_{d(off)}$			85	180 ns
t_{fi}			85	180 ns
E_{off}		0.27	0.60 mJ	
R_{thJC}			2.27	K/W
R_{thCK}		0.15		K/W

Note: $I_T = 12\text{ A}$

ISOPLUS 247 OUTLINE

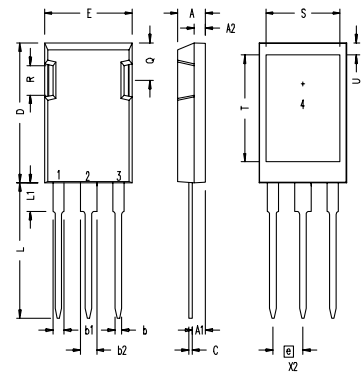

1 Gate, 2 Drain (Collector)
3 Source (Emitter)
4 no connection

Dim.	Millimeter		Inches	
	Min.	Max.	Min.	Max.
A	4.83	5.21	.190	.205
A ₁	2.29	2.54	.090	.100
A ₂	1.91	2.16	.075	.085
b	1.14	1.40	.045	.055
b ₁	1.91	2.13	.075	.084
b ₂	2.92	3.12	.115	.123
C	0.61	0.80	.024	.031
D	20.80	21.34	.819	.840
E	15.75	16.13	.620	.635
e	5.45 BSC		.215 BSC	
L	19.81	20.32	.780	.800
L1	3.81	4.32	.150	.170
Q	5.59	6.20	.220	.244
R	4.32	4.83	.170	.190

IXYS reserves the right to change limits, test conditions, and dimensions.

IXYS MOSFETS and IGBTs are covered by one or more of the following U.S. patents:	4,835,592	4,881,106	5,017,508	5,049,961	5,187,117	5,486,715	6,306,728B1
	4,850,072	4,931,844	5,034,796	5,063,307	5,237,481	5,381,025	