

Excellent Integrated System Limited

Stocking Distributor

Click to view price, real time Inventory, Delivery & Lifecycle Information:

[ON Semiconductor](#)
[NUC2401MNTAG](#)

For any questions, you can email us directly:

sales@integrated-circuit.com

NUC2401MN

Integrated Common Mode Choke with Integrated ESD Protection

Description

The NUC2401MN is an Integrated Common Mode Filter for the elimination of common mode noise in high speed data line applications such as IEEE1394, USB2.0 and other LVDS type applications. ESD protection is integrated into the Common mode filter for superior protection and significant part count reduction.

Features

- Common mode EMI Filtering and ESD Protection
- Integration of 5 Discrete components
- ± 12 kV ESD Protection per IEC61000-4-2 (Contact Discharge)
- DFN: 2.0 x 2.2 mm Package
- Moisture Sensitivity Level 1
- ESD Rating: Machine Model (MM) = 1.6 kV;
Human Body Model (HBM) = 16 kV
- This is a Pb-Free Device

Benefits

- Reduces EMI/RFI Emissions on a Data Line
- Integrated Solution offers Cost and Space Savings
- Reduces Parasitic Inductances Which Offer a More "Ideal" Common Mode Filtering
- Integrated Solution Improves System Reliability

Applications

- High Speed Differential Data Lines
- USB2.0
- IEEE1394
- LVDS
- MIPI
- MDDI



ON Semiconductor®

<http://onsemi.com>

SIMPLIFIED SCHEMATIC

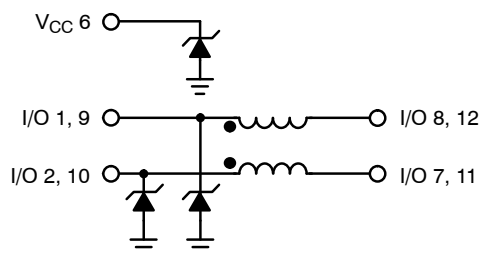

MARKING DIAGRAM

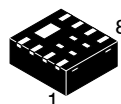

DFN8
CASE 506BL



C2 = Specific Device Code
 M = Date Code
 ■ = Pb-Free Device

(Note: Microdot may be in either location)

PIN CONNECTIONS*

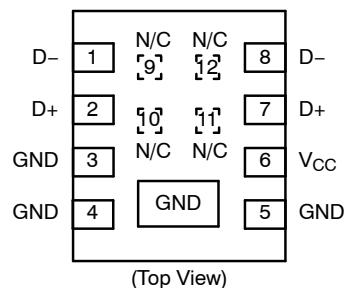

*NOTE: Pins 1 and 9, Pins 2 and 10, Pins 7 and 11, Pins 8 and 12 are internally connected in pairs. It is recommended not to solder to Pins 9, 10, 11, 12.

ORDERING INFORMATION

Device	Package	Shipping†
NUC2401MNTAG	DFN8 (Pb-Free)	3000/Tape & Reel

†For information on tape and reel specifications, including part orientation and tape sizes, please refer to our Tape and Reel Packaging Specification Brochure, BRD8011/D.

NUC2401MN

MAXIMUM RATINGS (T_A = 25°C unless otherwise stated)

Parameter	Symbol	Value	Units
ESD Discharge IEC61000-4-2 Contact Discharge	V _{PP}	±12	kV
Operating Temperature Range	T _{OP}	-40 to 85	°C
Storage Temperature Range	T _{STG}	-55 to 125	°C
Maximum Lead Temperature for Soldering Purposes (1/8" from Case for 10 Seconds)	T _L	260	°C
DC Current per Line	I _{LINE}	100	mA

Stresses exceeding Maximum Ratings may damage the device. Maximum Ratings are stress ratings only. Functional operation above the Recommended Operating Conditions is not implied. Extended exposure to stresses above the Recommended Operating Conditions may affect device reliability.

ELECTRICAL CHARACTERISTICS (T_A = 25°C unless otherwise specified)

Parameter	Symbol	Test Conditions	Min	Typ	Max	Unit
Maximum Reverse Working Voltage	V _{RWM}				5.0	V
Breakdown Voltage	V _{BR}	I _R = 1 mA	6.0	7.6	8.6	V
Leakage Current	I _R	V _{RWM} = 5.5 V			2.0	μA
Maximum Peak Pulse Current	I _{PP}	8x20 μs Waveform			12	A
Clamping Voltage	V _C	I _{PP} = 5 A			10	V
Resistance Pin 1 to Pin 8	R _A			2.2	5.0	Ω
Resistance Pin 2 to Pin 7	R _B			2.2	5.0	Ω
Capacitance (Note 1)	C _{LINE 1}			0.8	1.0	pF
Capacitance (Note 2)	C _{LINE 2}			0.8	1.0	pF
Common Mode Cut-Off Frequency (Note 3)	f _{3dB}	(Above this Frequency, Appreciable Common Mode Attenuation Occurs)		40		MHz
Common Mode Impedance	Z _C	@ 100 MHz		90		Ω

1. Measured at 25°C, V_R = 0 V, f = 1 MHz, Pins 1 or 4 to GND.
2. Measured at 25°C, V_R = 0 V, f = 1 MHz, Pins 8 or 5 to GND.
3. 50 Ω source and 50 Ω load termination.

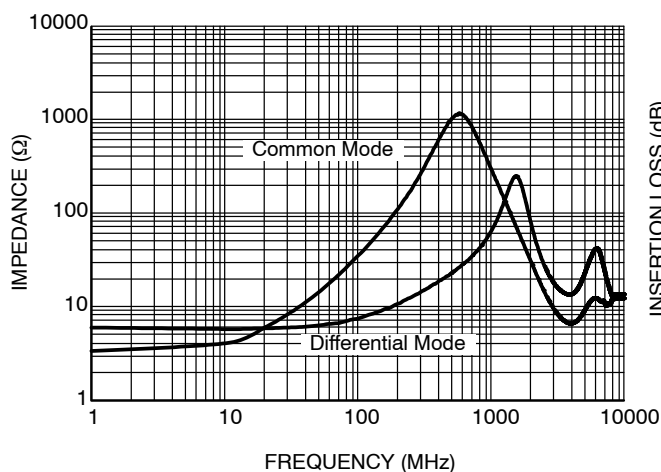

Figure 1. Impedance Characteristics vs. Frequency

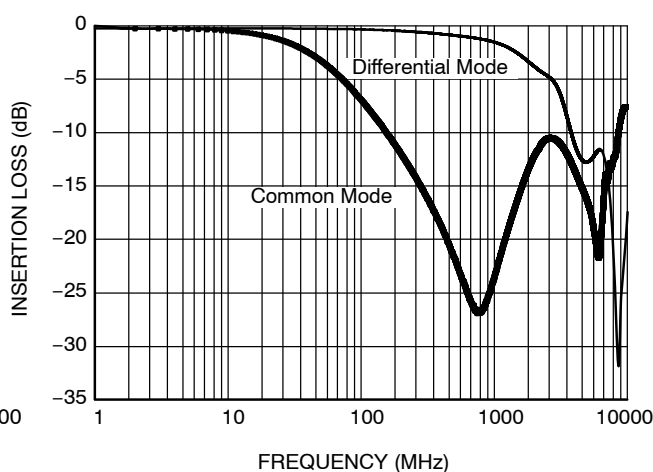

Figure 2. Insertion Loss Characteristics vs. Frequency

NUC2401MN

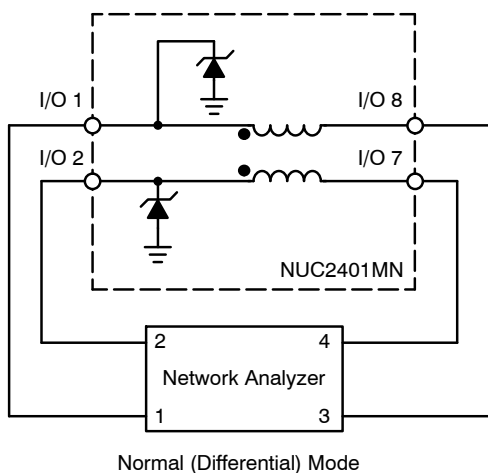

Figure 3. Normal (Differential) Mode Test Configuration

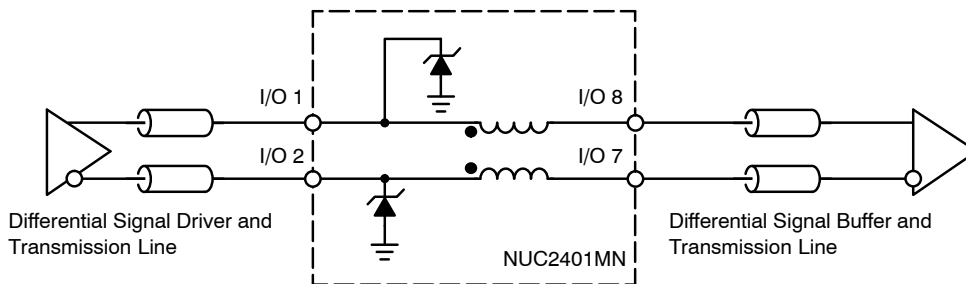
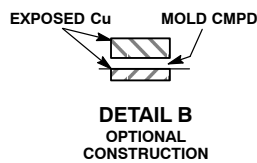
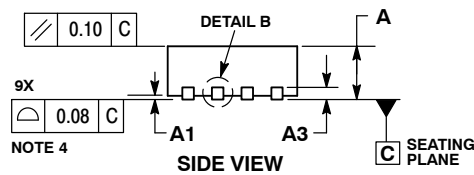
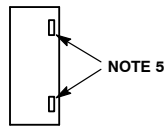
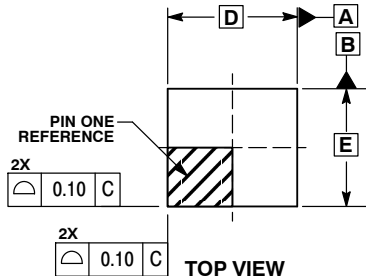

Figure 4. Application Circuit

NUC2401MN

PACKAGE DIMENSIONS

DFN8, 2.2x2, 0.5P
 CASE 506BL-01
 ISSUE O



- NOTES:
1. DIMENSIONING AND TOLERANCING PER ASME Y14.5M, 1994.
 2. CONTROLLING DIMENSION: MILLIMETERS.
 3. DIMENSION b APPLIES TO PLATED TERMINAL AND IS MEASURED BETWEEN 0.15 AND 0.30 mm FROM TERMINAL.
 4. COPLANARITY APPLIES TO THE EXPOSED PAD AS WELL AS THE TERMINALS.
 5. EXPOSED ENDS OF THE TERMINALS ARE ELECTRICALLY ACTIVE.

MILLIMETERS		
DIM	MIN	MAX
A	0.85	0.95
A1	0.00	0.05
A3	0.20	REF
b	0.15	0.25
D	2.20	BSC
D2	0.34	0.54
E	2.00	BSC
E2	0.60	0.80
e	0.50	BSC
K	0.20	---
L	0.30	0.50
L1	---	0.15

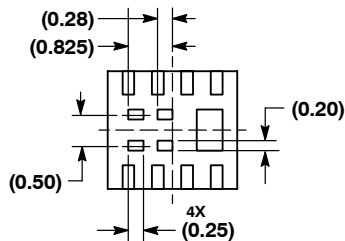
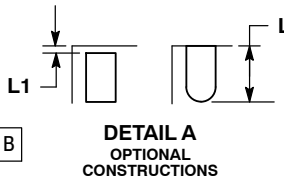
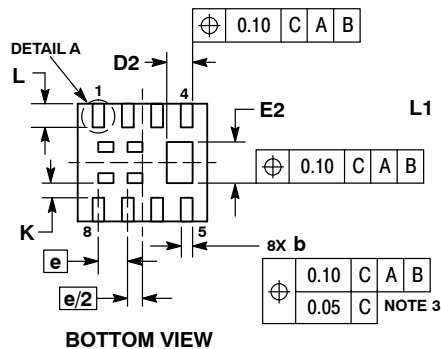

SOLDERING FOOTPRINT*

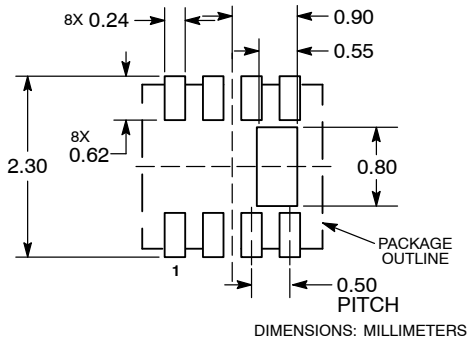

*For additional information on our Pb-Free strategy and soldering details, please download the ON Semiconductor Soldering and Mounting Techniques Reference Manual, SOLDERRM/D.

ON Semiconductor and are registered trademarks of Semiconductor Components Industries, LLC (SCILLC). SCILLC reserves the right to make changes without further notice to any products herein. SCILLC makes no warranty, representation or guarantee regarding the suitability of its products for any particular purpose, nor does SCILLC assume any liability arising out of the application or use of any product or circuit, and specifically disclaims any and all liability, including without limitation special, consequential or incidental damages. "Typical" parameters which may be provided in SCILLC data sheets and/or specifications can and do vary in different applications and actual performance may vary over time. All operating parameters, including "Typicals" must be validated for each customer application by customer's technical experts. SCILLC does not convey any license under its patent rights nor the rights of others. SCILLC products are not designed, intended, or authorized for use as components in systems intended for surgical implant into the body, or other applications intended to support or sustain life, or for any other application in which the failure of the SCILLC product could create a situation where personal injury or death may occur. Should Buyer purchase or use SCILLC products for any such unintended or unauthorized application, Buyer shall indemnify and hold SCILLC and its officers, employees, subsidiaries, affiliates, and distributors harmless against all claims, costs, damages, and expenses, and reasonable attorney fees arising out of, directly or indirectly, any claim of personal injury or death associated with such unintended or unauthorized use, even if such claim alleges that SCILLC was negligent regarding the design or manufacture of the part. SCILLC is an Equal Opportunity/Affirmative Action Employer. This literature is subject to all applicable copyright laws and is not for resale in any manner.

PUBLICATION ORDERING INFORMATION

LITERATURE FULFILLMENT:
 Literature Distribution Center for ON Semiconductor
 P.O. Box 5163, Denver, Colorado 80217 USA
 Phone: 303-675-2175 or 800-344-3860 Toll Free USA/Canada
 Fax: 303-675-2176 or 800-344-3867 Toll Free USA/Canada
 Email: orderlit@onsemi.com

N. American Technical Support: 800-282-9855 Toll Free
 USA/Canada
Europe, Middle East and Africa Technical Support:
 Phone: 421 33 790 2910
Japan Customer Focus Center
 Phone: 81-3-5773-3850

ON Semiconductor Website: www.onsemi.com

Order Literature: <http://www.onsemi.com/orderlit>

For additional information, please contact your local Sales Representative