

Excellent Integrated System Limited

Stocking Distributor

Click to view price, real time Inventory, Delivery & Lifecycle Information:

[Texas Instruments](#)
[CDCE937QPWRQ1](#)

For any questions, you can email us directly:

sales@integrated-circuit.com

PROGRAMMABLE 3-PLL VCXO CLOCK SYNTHESIZER WITH 1.8-V, 2.5-V, AND 3.3-V LVCMOS OUTPUTS

Check for Samples: [CDCE937-Q1](#), [CDCEL937-Q1](#)

FEATURES

- Qualified for Automotive Applications
- Member of Programmable Clock Generator Family
 - CDCE913/CDCEL913: 1-PLL, 3 Outputs
 - CDCE925/CDCEL925: 2-PLL, 5 Outputs
 - **CDCE937/CDCEL937: 3-PLL, 7 Outputs**
 - CDCE949/CDCEL949: 4-PLL, 9 Outputs
- In-System Programmability and EEPROM
 - Serial Programmable Volatile Register
 - Nonvolatile EEPROM to Store Customer Setting
- Flexible Input Clocking Concept
 - External Crystal: 8 MHz to 32 MHz
 - On-Chip VCXO: Pull Range ± 150 ppm
 - Single-Ended LVCMOS up to 160 MHz
- Selectable Output Frequency up to 230 MHz
- Low-Noise PLL Core
 - Integrated PLL Loop Filter Components
 - Low Period Jitter (Typ 60 ps)
- Separate Output Supply Pins
 - CDCE937: 3.3 V and 2.5 V
 - CDCEL937: 1.8 V

- 1.8-V Device Power Supply
- Flexible Clock Driver
 - Three User-Definable Control Inputs [S0/S1/S2]; e.g., SSC Selection, Frequency Switching, Output Enable or Power Down
 - Generates Highly Accurate Clocks for Video, Audio, USB, IEEE1394, RFID, Bluetooth™, WLAN, Ethernet™, and GPS
 - Generates Common Clock Frequencies Used With TI DaVinci™, OMAP™, DSPs
 - Programmable SSC Modulation
 - Enables 0-PPM Clock Generation
- Latch-Up Performance Meets 100 mA Per JESD 78, Class I
- Wide Temperature Range -40° C to 125° C
- Packaged in TSSOP
- Development and Programming Kit for Easy PLL Design and Programming (TI Pro-Clock™)

APPLICATIONS

- D-TV, HD-TV, STB, IP-STB, DVD-Player, DVD-Recorder, Printer

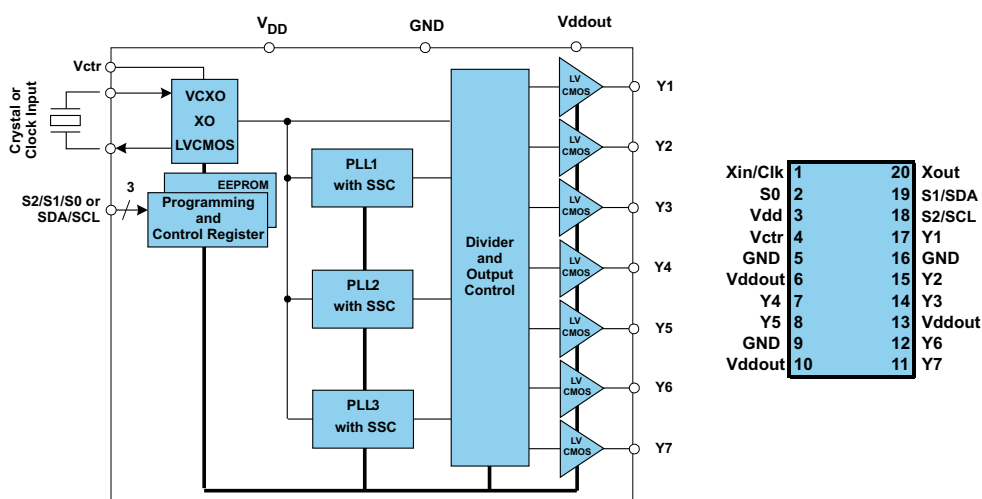

Please be aware that an important notice concerning availability, standard warranty, and use in critical applications of Texas Instruments semiconductor products and disclaimers thereto appears at the end of this data sheet.

CDCE937-Q1 CDCEL937-Q1

SCAS892B –FEBRUARY 2010–REVISED MAY 2010

www.ti.com



This integrated circuit can be damaged by ESD. Texas Instruments recommends that all integrated circuits be handled with appropriate precautions. Failure to observe proper handling and installation procedures can cause damage.

ESD damage can range from subtle performance degradation to complete device failure. Precision integrated circuits may be more susceptible to damage because very small parametric changes could cause the device not to meet its published specifications.

DESCRIPTION

The CDCE937 and CDCEL937 are modular PLL-based low-cost high-performance programmable clock synthesizers, multipliers, and dividers. It generates up to seven output clocks from a single input frequency. Each output can be programmed in-system for any clock frequency up to 230 MHz, using up to three independent configurable PLLs.

The CDCx937 has separate output supply pins, VDDOUT, which is 1.8 V for CDCEL937 and to 2.5 V to 3.3 V for CDCE937.

The input accepts an external crystal or LVCMOS clock signal. If an external crystal is used, an on-chip load capacitor is adequate for most applications. The value of the load capacitor is programmable from 0 to 20 pF. Additionally, an on-chip VCXO is selectable which allows synchronization of the output frequency to an external control signal, that is, PWM signal.

The deep M/N divider ratio allows the generation of zero ppm audio/video, networking (WLAN, BlueTooth, Ethernet, GPS) or Interface (USB, IEEE1394, Memory Stick) clocks from a reference input frequency such as 27 MHz.

All PLLs supports SSC (Spread-Spectrum Clocking). SSC can be Center-Spread or Down-Spread clocking which is a common technique to reduce electro-magnetic interference (EMI).

Based on the PLL frequency and the divider settings, the internal loop filter components are automatically adjusted to achieve high stability and optimized jitter transfer characteristic of each PLL.

The device supports non-volatile EEPROM programming for ease-customized application. It is preset to a factory default configuration (see the *Default Device Configuration* section). It can be reprogrammed to a different application configuration before PCB assembly, or reprogrammed by in-system programming. All device settings are programmable through SDA/SCL bus, a 2-wire serial interface.

Three programmable control inputs, S0, S1 and S2, can be used to control various aspects of operation including frequency selection changing the SSC parameters to lower EMI, PLL bypass, power down, and choosing between low level or 3-state for output-disable function.

The CDCEx937 operates in 1.8-V environment. It is characterized for operation from –40°C to 125°C.

ORDERING INFORMATION⁽¹⁾

T _A	PACKAGE ⁽²⁾		ORDERABLE PART NUMBER	TOP-SIDE MARKING
–40°C to 125°C	TSSOP – PW	Reel of 2000	CDCE937QPWRQ1	CDCE937Q
			CDCEL937QPWRQ1	CEL937Q

(1) For the most current package and ordering information, see the Package Option Addendum at the end of this document, or see the TI web site at www.ti.com.

(2) Package drawings, thermal data, and symbolization are available at www.ti.com/packaging.

Terminal Functions

NAME	PIN TSSOP24	TYPE	DESCRIPTION
Y1, Y2, ... Y7	17, 15, 14, 7, 8, 12, 11	O	LVC MOS outputs
Xin/CLK	1	I	Crystal oscillator input or LVC MOS clock input (selectable via SDA/SCL bus)
Xout	20	O	Crystal oscillator output (leave open or pull up (~500k) when not used)
V _{Ctrl}	4	I	VCXO control voltage (leave open or pull up (~500k) when not used)
V _{DD}	3	Power	1.8-V power supply for the device
V _{dout}	6, 10, 13	Power	CDCEL937: 1.8-V supply for all outputs
			CDCE937: 3.3-V or 2.5-V supply for all outputs
GND	5, 9, 16	Ground	Ground
S0	2	I	User-programmable control input S0; LVC MOS inputs; Internal pullup 500k
SDA/S1	19	I/O or I	SDA: Bidirectional serial data input/output (default configuration). LVC MOS; Internal pullup 500k; or S1: User-programmable control input; LVC MOS inputs; Internal pullup 500k
SCL/S2	18	I	SCL: Serial clock input(default configuration), LVC MOS; Internal pullup 500k; or S2: User-programmable control input; LVC MOS inputs; Internal pullup 500k

FUNCTIONAL BLOCK DIAGRAM

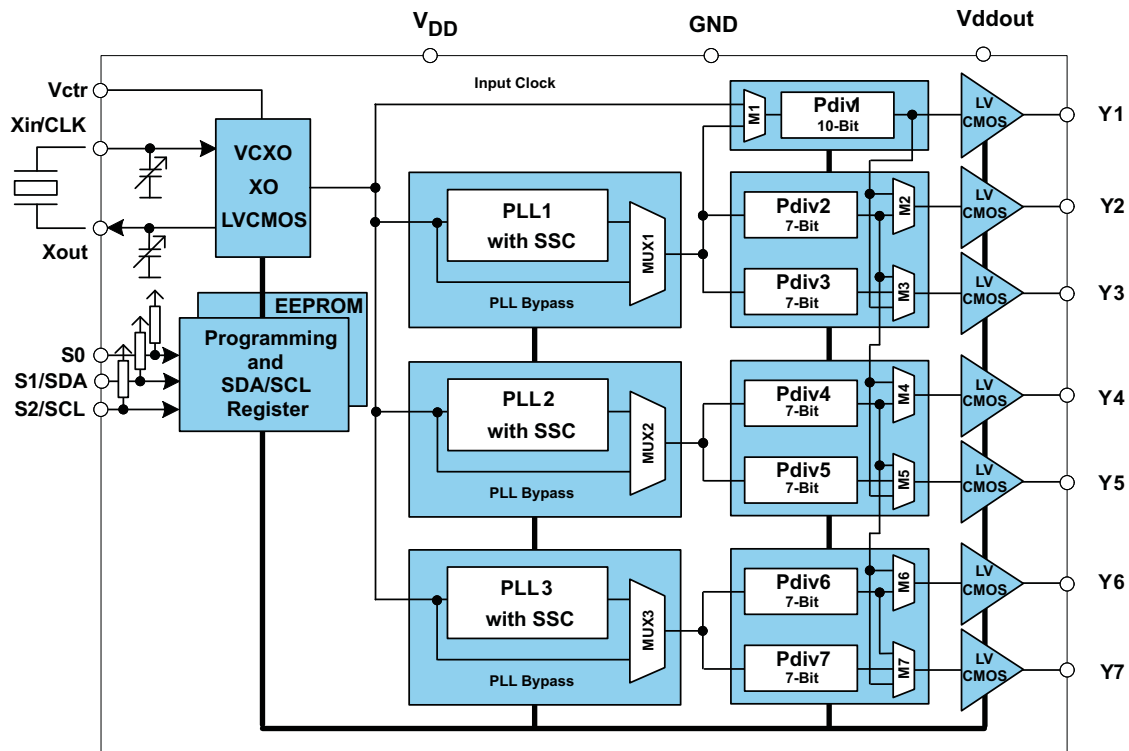

CDCE937-Q1
CDCEL937-Q1

SCAS892B – FEBRUARY 2010 – REVISED MAY 2010

www.ti.com
ABSOLUTE MAXIMUM RATINGS

 over operating free-air temperature range (unless otherwise noted)⁽¹⁾

		VALUE	UNIT
V _{DD}	Supply voltage range	–0.5 to 2.5	V
V _I	Input voltage range ⁽²⁾ ⁽³⁾	–0.5 to V _{DD} + 0.5	V
V _O	Output voltage range ⁽²⁾	–0.5 to V _{ddout} + 0.5	V
I _I	Input current (V _I < 0, V _I > V _{DD})	20	mA
I _O	Continuous output current	50	mA
T _{stg}	Storage temperature range	–65 to 150	°C

(1) Stresses beyond those listed under *absolute maximum ratings* may cause permanent damage to the device. These are stress ratings only and functional operation of the device at these or any other conditions beyond those indicated under *recommended operating conditions* is not implied. Exposure to absolute-maximum-rated conditions for extended periods may affect device reliability.

(2) The input and output negative voltage ratings may be exceeded if the input and output clamp-current ratings are observed.

(3) SDA and SCL can go up to 3.6 V as stated in the *Recommended Operating Conditions* table.

PACKAGE THERMAL RESISTANCE⁽¹⁾

over operating free-air temperature range (unless otherwise noted)

PARAMETER		AIRFLOW (lfm)	°C/W
T _{JA}	Thermal resistance, junction to ambient	0	89
		150	75
		200	74
		250	74
		500	69
T _{JC}	Thermal resistance, junction to case	—	31
T _{JB}	Thermal resistance, junction to board	—	55
R _{θJT}	Thermal resistance, junction to top	—	0.8
R _{θJB}	Thermal resistance, junction to bottom	—	49

(1) The package thermal impedance is calculated in accordance with JESD 51 and JEDEC2S2P (high-k board).

RECOMMENDED OPERATING CONDITIONS

		MIN	NOM	MAX	UNIT
V _{DD}	Device supply voltage	1.7	1.8	1.9	V
V _O	Output Yx supply voltage, V _{ddout}	CDCE937		3.6	V
		CDCEL937	1.7	1.9	
V _{IL}	Low-level input voltage LVCMOS			0.3 V _{DD}	V
V _{IH}	High-level input voltage LVCMOS	0.7 V _{DD}			V
V _{I(thresh)}	Input voltage threshold LVCMOS		0.5 V _{DD}		V
V _{IS}	Input voltage range S0	0		1.9	V
	Input voltage range S1, S2, SDA, SCL; V _{I(thresh)} = 0.5 V _{DD}	0		3.6	
V _{I(CLK)}	Input voltage range CLK	0		1.9	V
I _{OH} / I _{OL}	Output current (V _{ddout} = 3.3 V)			±12	mA
	Output current (V _{ddout} = 2.5 V)			±10	
	Output current (V _{ddout} = 1.8 V)			±8	
C _L	Output load LVCMOS			10	pF
T _A	Ambient temperature	–40		125	°C

RECOMMENDED CRYSTAL/VCXO SPECIFICATIONS⁽¹⁾

		MIN	NOM	MAX	UNIT
f_{Xtal}	Crystal input frequency range (fundamental mode)	8	27	32	MHz
ESR	Effective series resistance			100	Ω
f_{PR}	Pulling range ($0 V \leq V_{ctrl} \leq 1.8 V$) ⁽²⁾	± 120	± 150		ppm
	Frequency control voltage, V_{ctrl}	0		V_{DD}	V
C_0/C_1	Pullability ratio			220	
C_L	On-chip load capacitance at X_{in} and X_{out}	0		20	pF

(1) For more information about VCXO configuration, and crystal recommendation, see application report (SCAA085).

(2) Pulling range depends on crystal-type, on-chip crystal load capacitance and PCB stray capacitance; pulling range of min ± 120 ppm applies for crystal listed in the application report (SCAA085).

EEPROM SPECIFICATION

		MIN	TYP	MAX	UNIT
EEcyc	Programming cycles of EEPROM	1000			cycles
EEret	Data retention	10			years

CLK_IN TIMING REQUIREMENTS

over recommended ranges of supply voltage, load, and operating ambient temperature

		MIN	NOM	MAX	UNIT
f_{CLK}	LVC MOS clock input frequency	PLL bypass mode	0	160	MHz
		PLL mode	8	160	
t_r / t_f	Rise and fall time CLK signal (20% to 80%)			3	ns
duty _{CLK}	Duty cycle CLK at $V_{DD}/2$	40%		60%	

SDA/SCL TIMING REQUIREMENTS

see Figure 12

		STANDARD MODE		FAST MODE		UNIT
		MIN	MAX	MIN	MAX	
f_{SCL}	SCL clock frequency	0	100	0	400	kHz
$t_{su}(START)$	START setup time (SCL high before SDA low)	4.7		0.6		μs
$t_h(START)$	START hold time (SCL low after SDA low)	4		0.6		μs
$t_w(SCLL)$	SCL low-pulse duration	4.7		1.3		μs
$t_w(SCLH)$	SCL high-pulse duration	4		0.6		μs
$t_h(SDA)$	SDA hold time (SDA valid after SCL low)	0	3.45	0	0.9	μs
$t_{su}(SDA)$	SDA setup time	250		100		ns
t_r	SCL/SDA input rise time		1000		300	ns
t_f	SCL/SDA input fall time		300		300	ns
$t_{su}(STOP)$	STOP setup time	4		0.6		μs
t_{BUS}	Bus free time between a STOP and START condition	4.7		1.3		μs

**CDCE937-Q1
CDCEL937-Q1**

SCAS892B – FEBRUARY 2010 – REVISED MAY 2010

www.ti.com
DEVICE CHARACTERISTICS

over recommended operating ambient temperature range (unless otherwise noted)

PARAMETER		TEST CONDITIONS		MIN	TYP ⁽¹⁾	MAX	UNIT
OVERALL PARAMETER							
I _{DD}	Supply current (see Figure 3)	All outputs off, f _(CLK) = 27 MHz, f _(VCO) = 135 MHz	All PLLS on	29			mA
			Per PLL	9			
I _{DDOUT}	Output supply current (see Figure 4)	No load, all outputs on, f _{OUT} = 27 MHz	CDCE937, V _{DDOUT} = 3.3 V	3.1			mA
			CDCEL937, V _{DDOUT} = 1.8 V	1.5			
I _{DD(PD)}	Power-down current. Every circuit powered down except SDA/SCL.	f _{IN} = 0 MHz,	V _{DD} = 1.9 V	50			μA
V _(PUC)	Supply voltage V _{dd} threshold for power-up control circuit			0.85	1.45		V
f _(VCO)	VCO frequency range of PLL			80	230		MHz
f _{OUT}	LVCMOS output frequency	V _{ddout} = 3.3 V		230			MHz
		V _{ddout} = 1.8 V		230			
LVCMOS PARAMETER							
V _{IK}	LVCMOS input voltage	V _{DD} = 1.7 V; I _I = -18 mA				-1.2	V
I _I	LVCMOS Input current	V _I = 0 V or V _{DD} ; V _{DD} = 1.9 V				±5	μA
I _{IH}	LVCMOS Input current for S0/S1/S2	V _I = V _{DD} ; V _{DD} = 1.9 V				5	μA
I _{IL}	LVCMOS Input current for S0/S1/S2	V _I = 0 V; V _{DD} = 1.9 V				-6	μA
C _I	Input capacitance at Xin/Clk	V _{I(CLK)} = 0 V or V _{DD}		6			pF
	Input capacitance at Xout	V _{I(Xout)} = 0 V or V _{DD}		2			
	Input capacitance at S0/S1/S2	V _{IS} = 0 V or V _{DD}		3			
LVCMOS PARAMETER FOR V_{ddout} = 3.3 V (CDCE937)							
V _{OH}	LVCMOS high-level output voltage	V _{ddout} = 3 V, I _{OH} = -0.1 mA		2.9			V
		V _{ddout} = 3 V, I _{OH} = -8 mA		2.4			
		V _{ddout} = 3 V, I _{OH} = -12 mA		2.2			
V _{OL}	LVCMOS low-level output voltage	V _{ddout} = 3 V, I _{OL} = 0.1 mA				0.1	V
		V _{ddout} = 3 V, I _{OL} = 8 mA				0.5	
		V _{ddout} = 3 V, I _{OL} = 12 mA				0.8	
t _{PLH} , t _{PHL}	Propagation delay	All PLL bypass		3.2			ns
t _r /t _f	Rise and fall time	V _{ddout} = 3.3 V (20%–80%)		0.6			ns
t _{jitter(cc)}	Cycle-to-cycle jitter ⁽²⁾ ⁽³⁾	1 PLL switching, Y2-to-Y3		60	90		ps
		3 PLL switching, Y2-to-Y7		100	150		
t _{jitter(per)}	Peak-to-peak period jitter ⁽³⁾	1 PLL switching, Y2-to-Y3		70	100		ps
		3 PLL switching, Y2-to-Y7		120	180		
t _{sk(o)}	Output skew ⁽⁴⁾ , See Table 2	f _{OUT} = 50 MHz; Y1-to-Y3		60			ps
		f _{OUT} = 50 MHz; Y2-to-Y5		160			
odc	Output duty cycle ⁽⁵⁾	f _{VCO} = 100 MHz; Pdiv = 1		45%	55%		

 (1) All typical values are at respective nominal V_{DD}.

(2) 10000 cycles.

 (3) Jitter depends on configuration. Data is taken under the following conditions: 1-PLL : f_{IN} = 27MHz, Y2/3 = 27 MHz, (measured at Y2), 3-PLL: f_{IN} = 27 MHz, Y2/3 = 27 MHz (measured at Y2), Y4/5 = 16.384 MHz, Y6/7 = 74.25 MHz

 (4) The t_{sk(o)} specification is only valid for equal loading of each bank of outputs, and outputs are generated from the same divider; data taking on rising edge (tr).

 (5) odc depends on output rise and fall time (t_r/t_f).

DEVICE CHARACTERISTICS (continued)

over recommended operating ambient temperature range (unless otherwise noted)

PARAMETER	TEST CONDITIONS	MIN	TYP ⁽¹⁾	MAX	UNIT
LVC MOS PARAMETER for V_{ddout} = 2.5 V (CDCE937)					
V _{OH}	LVCMOS high-level output voltage	V _{ddout} = 2.3 V, I _{OH} = -0.1 mA	2.2		V
		V _{ddout} = 2.3 V, I _{OH} = -6 mA	1.7		
		V _{ddout} = 2.3 V, I _{OH} = -10 mA	1.6		
V _{OL}	LVCMOS low-level output voltage	V _{ddout} = 2.3 V, I _{OL} = 0.1 mA		0.1	V
		V _{ddout} = 2.3 V, I _{OL} = 6 mA		0.5	
		V _{ddout} = 2.3 V, I _{OL} = 10 mA		0.7	
t _{PLH} , t _{PHL}	Propagation delay	All PLL bypass		3.4	ns
t _r /t _f	Rise and fall time	V _{ddout} = 2.5 V (20%–80%)		0.8	ns
t _{jitter(cc)}	Cycle-to-cycle jitter ⁽⁶⁾ (7)	1 PLL switching, Y2-to-Y3	60	90	ps
		3 PLL switching, Y2-to-Y7	100	150	
t _{jitter(per)}	Peak-to-peak period jitter ⁽⁸⁾	1 PLL switching, Y2-to-Y3	70	100	ps
		3 PLL switching, Y2-to-Y7	120	180	
t _{sk(o)}	Output skew ⁽⁸⁾ , See Table 2	f _{OUT} = 50 MHz; Y1-to-Y3		60	ps
		f _{OUT} = 50 MHz; Y2-to-Y5		160	
odc	Output duty cycle ⁽⁹⁾	f _(VCO) = 100 MHz; Pdiv = 1	45%	55%	
LVC MOS PARAMETER for V_{ddout} = 1.8 V (CDCEL937)					
V _{OH}	LVCMOS high-level output voltage	V _{ddout} = 1.7 V, I _{OH} = -0.1 mA	1.6		V
		V _{ddout} = 1.7 V, I _{OH} = -4 mA	1.4		
		V _{ddout} = 1.7 V, I _{OH} = -8 mA	1.1		
V _{OL}	LVCMOS low-level output voltage	V _{ddout} = 1.7 V, I _{OL} = 0.1 mA		0.1	V
		V _{ddout} = 1.7 V, I _{OL} = 4 mA		0.3	
		V _{ddout} = 1.7 V, I _{OL} = 8 mA		0.6	
t _{PLH} , t _{PHL}	Propagation delay	All PLL bypass		2.6	ns
t _r /t _f	Rise and fall time	V _{ddout} = 1.8 V (20%–80%)		0.7	ns
t _{jitter(cc)}	Cycle-to-cycle jitter ⁽⁶⁾ (7)	1 PLL switching, Y2-to-Y3	70	120	ps
		3 PLL switching, Y2-to-Y7	100	150	
t _{jitter(per)}	Peak-to-peak period jitter ⁽⁷⁾	1 PLL switching, Y2-to-Y3	90	140	ps
		3 PLL switching, Y2-to-Y7	120	190	
t _{sk(o)}	Output skew ⁽⁸⁾ , See Table 2	f _{OUT} = 50 MHz; Y1-to-Y3		60	ps
		f _{OUT} = 50 MHz; Y2-to-Y5		160	
odc	Output duty cycle ⁽⁹⁾	f _(VCO) = 100 MHz; Pdiv = 1	45%	55%	
SDA/SCL PARAMETER					
V _{IK}	SCL and SDA input clamp voltage	V _{DD} = 1.7 V; I _I = -18 mA		-1.2	V
I _{IH}	SCL and SDA input current	V _I = V _{DD} ; V _{DD} = 1.9 V		±10	μA
V _{IH}	SDA/SCL input high voltage ⁽¹⁰⁾		0.7 V _{DD}		V
V _{IL}	SDA/SCL input low voltage ⁽¹⁰⁾			0.3 V _{DD}	V
V _{OL}	SDA low-level output voltage	I _{OL} = 3 mA, V _{DD} = 1.7 V		0.2 V _{DD}	V
C _I	SCL/SDA Input capacitance	V _I = 0 V or V _{DD}	3	10	pF

(6) 10000 cycles.

(7) Jitter depends on configuration. Data is taken under the following conditions: 1-PLL : f_{IN} = 27MHz, Y2/3 = 27 MHz, (measured at Y2), 3-PLL: f_{IN} = 27 MHz, Y2/3 = 27 MHz (measured at Y2), Y4/5 = 16.384 MHz, Y6/7 = 74.25 MHz

(8) The t_{sk(o)} specification is only valid for equal loading of each bank of outputs, and outputs are generated from the same divider; data taking on rising edge (tr).

(9) odc depends on output rise and fall time (t_r/t_f).

(10) SDA and SCL pins are 3.3 V tolerant.

PARAMETER MEASUREMENT INFORMATION

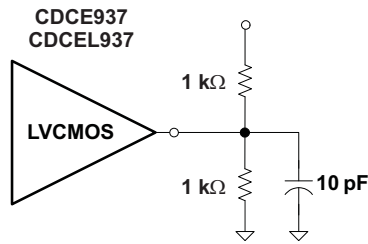

Figure 1. Test Load

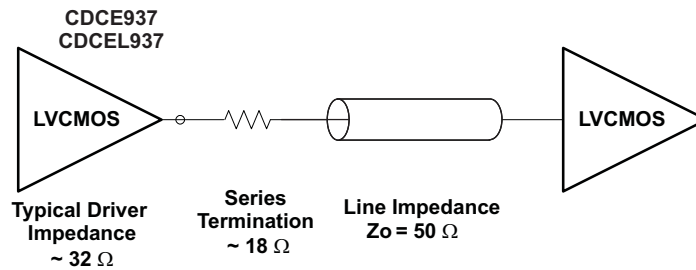

Figure 2. Test Load for 50-Ω Board Environment

TYPICAL CHARACTERISTICS

**CDCE937, CDCEL937
SUPPLY CURRENT
vs
PLL FREQUENCY**

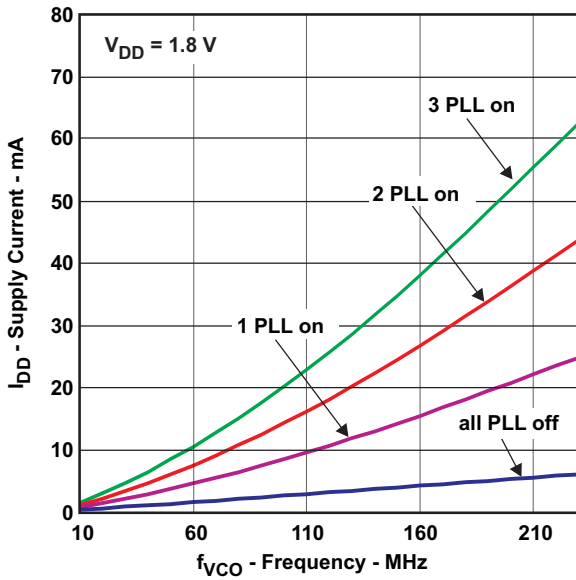

Figure 3.

**CDCE937
OUTPUT CURRENT
vs
OUTPUT FREQUENCY**

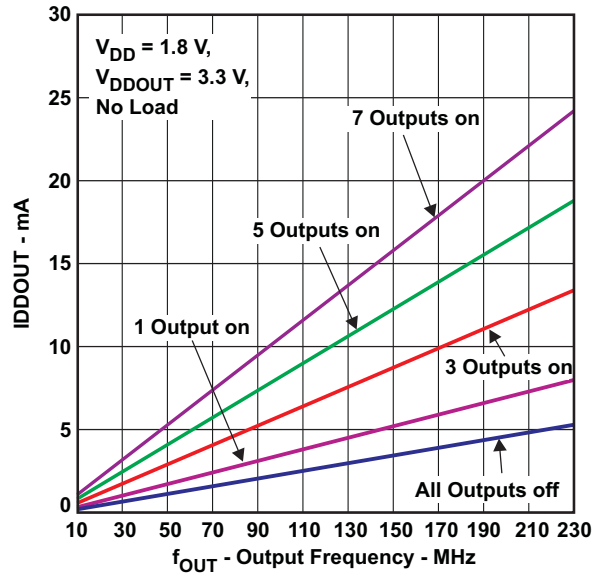

Figure 4.

**CDCEL937
OUTPUT CURRENT
vs
OUTPUT FREQUENCY**

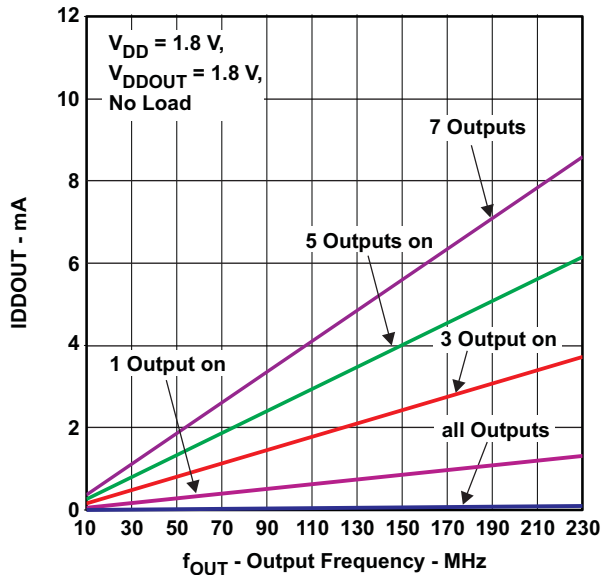

Figure 5.

CDCE937-Q1 CDCEL937-Q1

SCAS892B – FEBRUARY 2010 – REVISED MAY 2010

www.ti.com

APPLICATION INFORMATION

CONTROL TERMINAL SETTING

The CDCE937/CDCEL937 has three user-definable control terminals (S0, S1, and S2) that allow external control of device settings. They can be programmed to any of the following setting:

- Spread spectrum clocking selection → spread type and spread amount selection
- Frequency selection → switching between any of two user-defined frequencies
- Output state selection → output configuration and power down control

The user can predefine up to eight different control settings. [Table 1](#) and [Table 2](#) explain these settings.

Table 1. Control Terminal Definition

External Control Bits	PLL1 Setting			PLL2 Setting			PLL3 Setting			Y1 Setting
	Control Function	PLL Frequency Selection	SSC Selection	Output Y2/Y3 Selection	PLL Frequency Selection	SSC Selection	Output Y4/Y5 Selection	PLL Frequency Selection	SSC Selection	

Table 2. PLLx Setting (can be selected for each PLL individual)⁽¹⁾

SSC Selection (Center/Down)				
SSCx [3-bits]			Center	Down
0	0	0	0% (off)	0% (off)
0	0	1	±0.25%	–0.25%
0	1	0	±0.5%	–0.5%
0	1	1	±0.75%	–0.75%
1	0	0	±1.0%	–1.0%
1	0	1	±1.25%	–1.25%
1	1	0	±1.5%	–1.5%
1	1	1	±2.0%	–2.0%
FREQUENCY SELECTION ⁽²⁾				
FSx		FUNCTION		
0		Frequency0		
1		Frequency1		
OUTPUT SELECTION ⁽³⁾ (Y2 ... Y7)				
YxYx		FUNCTION		
0		State0		
1		State1		

- (1) Center/Down-Spread, Frequency0/1 and State0/1 are user-definable in PLLx Configuration Register;
- (2) Frequency0 and Frequency1 can be any frequency within the specified f_{VCO} range.
- (3) State0/1 selection is valid for both outputs of the corresponding PLL module and can be power down, 3-state, low or active

Table 3. Y1 Setting⁽¹⁾

Y1 SELECTION	
Y1	FUNCTION
0	State 0
1	State 1

- (1) State0 and State1 are user definable in Generic Configuration Register and can be power down, 3-state, low, or active.

S1/SDA and S2/SCL pins of the CDCE937/CDCEL937 are dual function pins. In default configuration they are defined as SDA/SCL for the serial interface. They can be programmed as control-pins (S1/S2) by setting the relevant bits in the EEPROM. Note that the changes to the Control register (Bit [6] of Byte [02]) have no effect until they are written into the EEPROM.

Once they are set as control pins, the serial programming interface is no longer available. However, if V_{DDOUT} is forced to GND, the two control-pins, S1 and S2, temporally act as serial programming pins (SDA/SCL).

S0 is not a multi-use pin, it is a control pin only.

DEFAULT DEVICE SETTING

The internal EEPROM of CDCE937/CDCEL937 is preconfigured as shown in Figure 6. (The input frequency is passed through to the output as a default). This allows the device to operate in default mode without the extra production step of program it. The default setting appears after power is supplied or after power-down/up sequence until it is re-programmed by the user to a different application configuration. A new register setting is programmed via the serial SDA/SCL Interface.

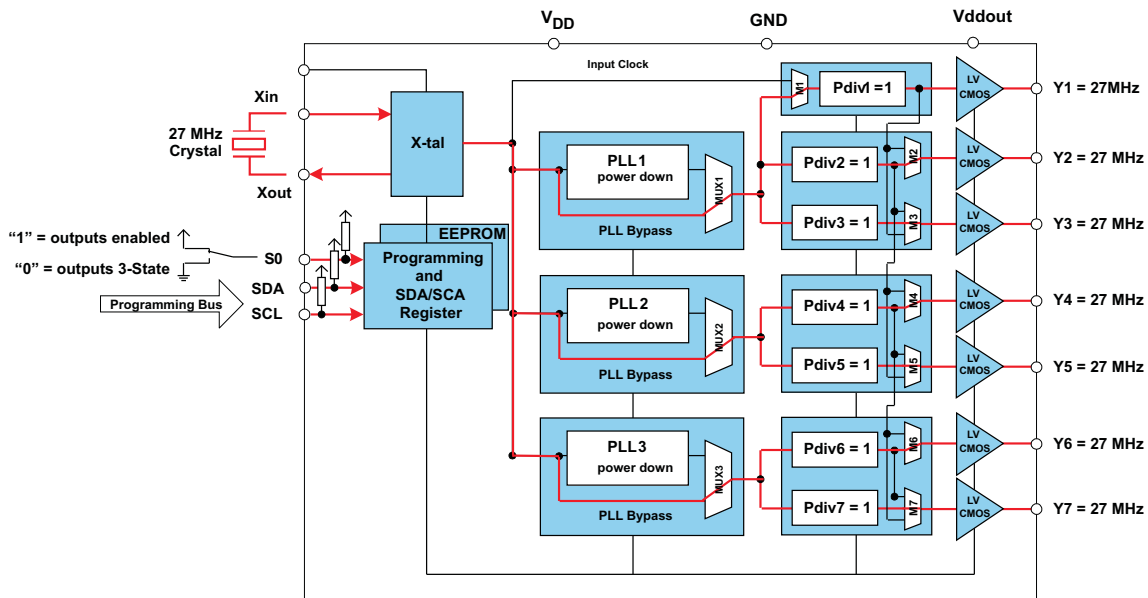

Figure 6. Default Device Setting

Table 4 shows the factory default setting for the Control Terminal Register (external control pins). In normal operation, all 8 register settings are available, but in the default configuration only the first two settings (0 and 1) can be selected with S0, as S1 and S2 configured as programming pins in default mode.

Table 4. Factory Default Setting for Control Terminal Register⁽¹⁾

			Y1	PLL1 Settings			PLL2 Settings			PLL3 Settings		
External Control Pins			Output Selection	Frequency Selection	SSC Selection	Output Selection	Frequency Selection	SSC Selection	Output Selection	Frequency Selection	SSC Selection	Output Selection
S2	S1	S0	Y1	FS1	SSC1	Y2Y3	FS2	SSC2	Y4Y5	FS3	SSC3	Y6Y7
SCL (I2C)	SDA (I2C)	0	3-state	f _{VC01_0}	off	3-state	f _{VC02_0}	off	3-state	f _{VC01_0}	off	3-state
SCL (I2C)	SDA (I2C)	1	enabled	f _{VC01_0}	off	enabled	f _{VC02_0}	off	enabled	f _{VC01_0}	off	enabled

(1) In default mode or when programmed respectively, S1 and S2 act as serial programming interface, SDA/SCL. They do not have any control-pin function but they are internally interpreted as if S1=0 and S2=0. S0, however, is a control-pin which in the default mode switches all outputs ON or OFF (as previously predefined).

CDCE937-Q1 CDCEL937-Q1

SCAS892B – FEBRUARY 2010 – REVISED MAY 2010

www.ti.com

SDA/SCL SERIAL INTERFACE

The CDCE937/CDCEL937 operates as a slave device of the 2-wire serial SDA/SCL bus, compatible with the popular SMBus or I²C specification. It operates in the standard-mode transfer (up to 100kbit/s) and fast-mode transfer (up to 400kbit/s) and supports 7-bit addressing.

The S1/SDA and S2/SCL pins of the CDC9xx are dual function pins. In the default configuration they are used as SDA/SCL serial programming interface. They can be re-programmed as general purpose control pins, S1 and S2, by changing the corresponding EEPROM setting, Byte 02, Bit [6].

DATA PROTOCOL

The device supports *Byte Write and Byte Read* and *Block Write and Block Read* operations.

For *Byte Write/Read* operations, the system controller can individually access addressed bytes.

For *Block Write/Read* operations, the bytes are accessed in sequential order from lowest to highest byte (with most significant bit first) with the ability to stop after any complete byte has been transferred. The numbers of Bytes read-out are defined by Byte Count in the Generic Configuration Register. At Block Read instruction all bytes defined in the Byte Count has to be readout to correctly finish the read cycle.

Once a byte has been sent, it is written into the internal register and is effective immediately. This applies to each transferred byte independent of whether this is a *Byte Write* or a *Block Write* sequence.

If the EEPROM Write Cycle is initiated, the internal SDA register contents are written into the EEPROM. During this write cycle, data is not accepted at the SDA/SCL bus until the write cycle is completed. However, data can be read during the programming sequence (Byte Read or Block Read). The programming status can be monitored by reading *EEPIP*, Byte 01–Bit [6].

The offset of the indexed byte is encoded in the command code, as described in [Table 5](#).

Table 5. Slave Receiver Address (7 Bits)

DEVICE	A6	A5	A4	A3	A2	A1 ⁽¹⁾	A0 ⁽¹⁾	R/W
CDCE913/CDCEL913	1	1	0	0	1	0	1	1/0
CDCE925/CDCEL925	1	1	0	0	1	0	0	1/0
CDCE937/CDCEL937	1	1	0	1	1	0	1	1/0
CDCE949/CDCEL949	1	1	0	1	1	0	0	1/0

(1) Address bits A0 and A1 are programmable via the SDA/SCL bus (Byte 01, Bit [1:0]). This allows addressing up to 4 devices connected to the same SDA/SCL bus. The least-significant bit of the address byte designates a write or read operation.

COMMAND CODE DEFINITION

Table 6. Command Code Definition

BIT	DESCRIPTION
7	0 = <i>Block Read</i> or <i>Block Write</i> operation 1 = <i>Byte Read</i> or <i>Byte Write</i> operation
(6:0)	Byte Offset for <i>Byte Read</i> , <i>Block Read</i> , <i>Byte Write</i> and <i>Block Write</i> operation.

Generic Programming Sequence

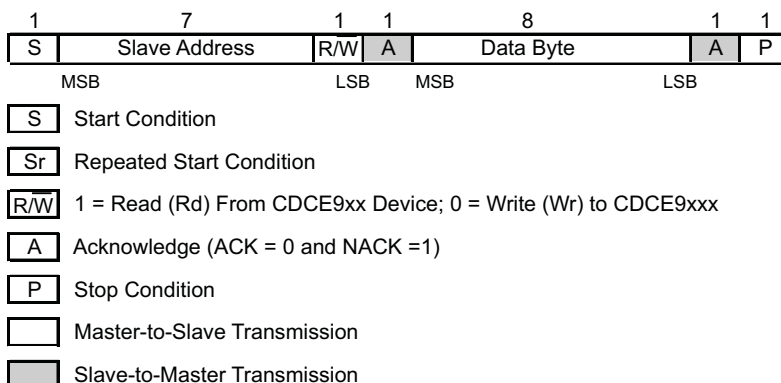

Figure 7. Generic Programming Sequence

Byte Write Programming Sequence



Figure 8. Byte Write Protocol

Byte Read Programming Sequence

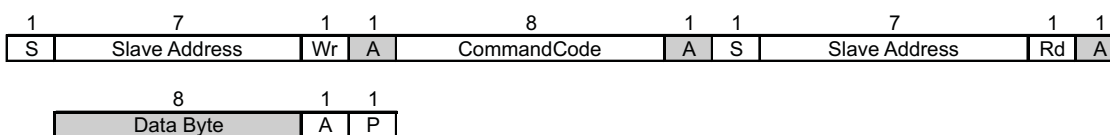
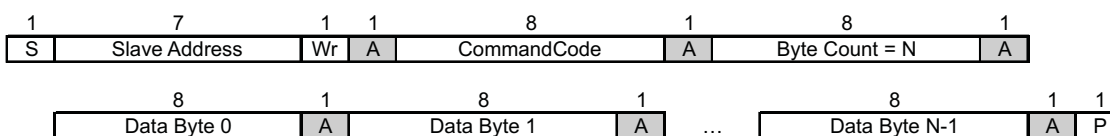

Figure 9. Byte Read Protocol

Block Write Programming Sequence



- (1) Data byte 0 bits [7:0] is reserved for Revision Code and Vendor Identification. Also, it is used for internal test purpose and should not be overwritten.

Figure 10. Block Write Protocol

Block Read Programming Sequence

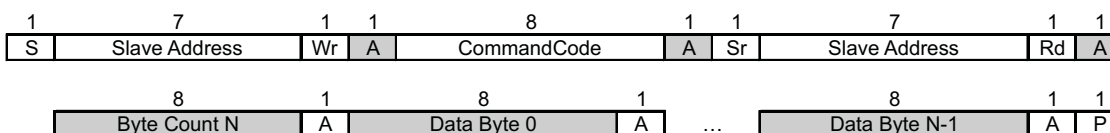

Figure 11. Block Read Protocol

CDCE937-Q1
CDCEL937-Q1

SCAS892B –FEBRUARY 2010–REVISED MAY 2010

www.ti.com

Timing Diagram for the SDA/SCL Serial Control Interface

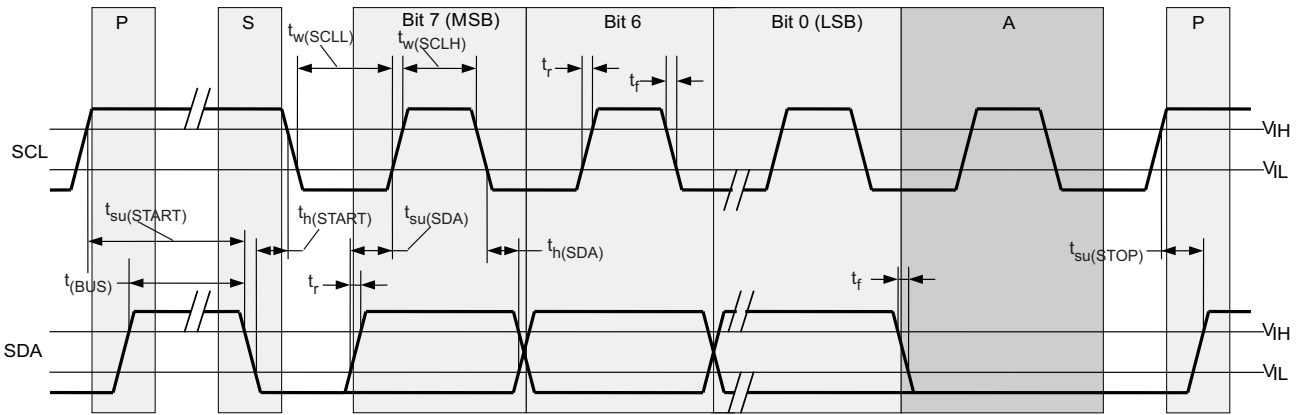

Figure 12. Timing Diagram for SDA/SCL Serial Control Interface

SDA/SCL HARDWARE INTERFACE

Figure 13 shows how the CDCE937/CDCEL937 clock synthesizer is connected to the SDA/SCL serial interface bus. Multiple devices can be connected to the bus but the speed may need to be reduced (400 kHz is the maximum) if many devices are connected.

Note that the pullup resistors (R_p) depends on the supply voltage, bus capacitance, and number of connected devices. The recommended pullup value is 4.7 k Ω . It must meet the minimum sink current of 3 mA at $V_{OLmax} = 0.4$ V for the output stages (for more details see SMBus or I²C Bus specification).

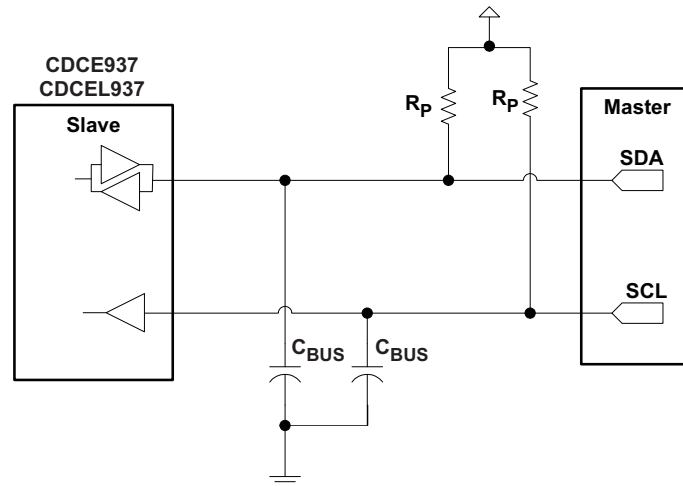

Figure 13. SDA / SCL Hardware Interface

SDA/SCL CONFIGURATION REGISTERS

The clock input, control pins, PLLs, and output stages are user configurable. The following tables and explanations describe the programmable functions of the CDCE937/CDCEL937. All settings can be manually written into the device via the SDA/SCL bus or easily programmed by using the TI Pro-Clock™ software. TI Pro-Clock™ software allows the user to quickly make all settings and automatically calculates the values for optimized performance at lowest jitter.

Table 7. SDA/SCL Registers

Address Offset	Register Description	Table
00h	Generic Configuration Register	Table 9
10h	PLL1 Configuration Register	Table 10
20h	PLL2 Configuration Register	Table 11
30h	PLL3 Configuration Register	Table 12

The grey-highlighted bits, described in the Configuration Registers tables in the following pages, belong to the Control Terminal Register. The user can predefine up to eight different control settings. These settings then can be selected by the external control pins, S0, S1, and S2 (see the *Control Terminal Configuration* section).

Table 8. Configuration Register, External Control Terminals

	External Control Pins			Y1	PLL1 Settings			PLL2 Settings			PLL3 Settings		
	S2	S1	S0	Output Selection	Freq. Selection	SSC Selection	Output Selection	Freq. Selection	SSC Selection	Output Selection	Freq. Selection	SSC Selection	Output Selection
	Y1	FS1	SSC1	Y2Y3	FS2	SSC2	Y4Y5	FS3	SSC3	Y6Y7			
0	0	0	0	Y1_0	FS1_0	SSC1_0	Y2Y3_0	FS2_0	SSC2_0	Y4Y5_0	FS3_0	SSC3_0	Y6Y7_0
1	0	0	1	Y1_1	FS1_1	SSC1_1	Y2Y3_1	FS2_1	SSC2_1	Y4Y5_1	FS3_1	SSC3_1	Y6Y7_1
2	0	1	0	Y1_2	FS1_2	SSC1_2	Y2Y3_2	FS2_2	SSC2_2	Y4Y5_2	FS3_2	SSC3_2	Y6Y7_2
3	0	1	1	Y1_3	FS1_3	SSC1_3	Y2Y3_3	FS2_3	SSC2_3	Y4Y5_3	FS3_3	SSC3_3	Y6Y7_3
4	1	0	0	Y1_4	FS1_4	SSC1_4	Y2Y3_4	FS2_4	SSC2_4	Y4Y5_4	FS3_4	SSC3_4	Y6Y7_4
5	1	0	1	Y1_5	FS1_5	SSC1_5	Y2Y3_5	FS2_5	SSC2_5	Y4Y5_5	FS3_5	SSC3_5	Y6Y7_5
6	1	1	0	Y1_6	FS1_6	SSC1_6	Y2Y3_6	FS2_6	SSC2_6	Y4Y5_6	FS3_6	SSC3_6	Y6Y7_6
7	1	1	1	Y1_7	FS1_7	SSC1_7	Y2Y3_7	FS2_7	SSC2_7	Y4Y5_7	FS3_7	SSC3_7	Y6Y7_7
	Address Offset ⁽¹⁾			04h	13h	10h–12h	15h	23h	20h–22h	25h	33h	30h–32h	35h

(1) Address Offset refers to the byte address in the Configuration Register in the following pages.

CDCE937-Q1
CDCEL937-Q1

SCAS892B –FEBRUARY 2010–REVISED MAY 2010

www.ti.com

Table 9. Generic Configuration Register

Offset ⁽¹⁾	Bit ⁽²⁾	Acronym	Default ⁽³⁾	Description
00h	7	E_EL	Xb	Device identification (read-only): 1 is CDCE937 (3.3 V), 0 is CDCEL937 (1.8 V)
	6:4	RID	Xb	Revision Identification Number (read only)
	3:0	VID	1h	Vendor Identification Number (read only)
01h	7	–	0b	Reserved – always write 0
	6	EEPIP	0b	EEPROM Programming Status: ⁽⁴⁾ (read only) 0 – EEPROM programming is completed 1 – EEPROM is in programming mode
	5	EELOCK	0b	Permanently Lock EEPROM Data ⁽⁵⁾ 0 – EEPROM is not locked 1 – EEPROM will be permanently locked
	4	PWDN	0b	Device Power Down (overwrites S0/S1/S2 setting; configuration register settings are unchanged) Note: PWDN cannot be set to 1 in the EEPROM. 0 – device active (PLL1 and all outputs are enabled) 1 – device power down (PLL1 in power down and all outputs in 3-state)
	3:2	INCLK	00b	Input clock selection: 00 – Xtal 01 – VCXO 10 – LVCMOS 11 – reserved
	1:0	SLAVE_ADR	01b	Programmable Address Bits A0 and A1 of the Slave Receiver Address
02h	7	M1	1b	Clock source selection for output Y1: 0 – input clock 1 – PLL1 clock
	6	SPICON	0b	Operation mode selection for pin 18/19 ⁽⁶⁾ 0 – serial programming interface SDA (pin 19) and SCL (pin 18) 1 – control pins S1 (pin 19) and S2 (pin 18)
	5:4	Y1_ST1	11b	Y1-State0/1 Definition
	3:2	Y1_ST0	01b	00 – device power down (all PLLs in power down and all outputs in 3-State) 10 – Y1 disabled to low 01 – Y1 disabled to 3-state 11 – Y1 enabled
	1:0	Pdiv1 [9:8]	001h	10-Bit Y1-Output-Divider Pdiv1: 0 – divider reset and stand-by 1-to-1023 – divider value
03h	7:0	Pdiv1 [7:0]		
04h	7	Y1_7	0b	Y1_ST0/Y1_ST1 State Selection ⁽⁷⁾ 0 – State0 (predefined by Y1_ST0) 1 – State1 (predefined by Y1_ST1)
	6	Y1_6	0b	
	5	Y1_5	0b	
	4	Y1_4	0b	
	3	Y1_3	0b	
	2	Y1_2	0b	
	1	Y1_1	1b	
	0	Y1_0	0b	
05h	7:3	XCSEL	0Ah	Crystal Load Capacitor Selection ⁽⁸⁾ 00h → 0 pF 01h → 1 pF 02h → 2 pF : 14h-to-1Fh → 20 pF
	2:0	–	0b	Reserved – do not write other than 0
06h	7:1	BCOUNT	40h	7-Bit Byte Count (defines the number of bytes which will be sent from this device at the next Block Read transfer); all bytes have to be read out to correctly finish the read cycle.)
	0	EEWRITE	0b	Initiate EEPROM Write Cycle ⁽⁴⁾ (9) 0 – no EEPROM write cycle 1 – start EEPROM write cycle (internal configuration register is saved to the EEPROM)

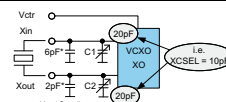

- (1) Writing data beyond '40h' may affect device function.
- (2) All data transferred with the MSB first.
- (3) Unless customer-specific setting.
- (4) During EEPROM programming, no data is allowed to be sent to the device via the SDA/SCL bus until the programming sequence is completed. Data, however, can be read out during the programming sequence (Byte Read or Block Read).
- (5) If this bit is set to high in the EEPROM, the actual data in the EEPROM will be permanently locked. There is no further programming possible. Data, however, can still be written via SDA/SCL bus to the internal register to change device function on the fly. But new data can no longer be saved to the EEPROM. EELOCK is effective only, if written into the EEPROM!
- (6) Selection of "control pins" is effective only if written into the EEPROM. Once written into the EEPROM, the serial programming pins are no longer available. However, if V_{DDOUT} is forced to GND, the two control pins, S1 and S2, temporarily act as serial programming pins (SDA/SCL), and the two slave receiver address bits are reset to A0="0" and A1="0".
- (7) These are the bits of the Control Terminal Register. The user can predefine up to eight different control settings. These settings then can be selected by the external control pins, S0, S1, and S2.
- (8) The internal load capacitor (C1, C2) has to be used to achieve the best clock performance. External capacitors should be used only to finely adjust C_L by a few pF's. The value of C_L can be programmed with a resolution of 1 pF for a crystal load range of 0 pF to 20 pF. For C_L > 20 pF, use additional external capacitors. Also, the value of the device input capacitance has to be considered which always adds 1.5 pF (6 pF//2 pF) to the selected C_L. For more information about VCXO configuration and crystal recommendation, see application report [SCAA085](#).
- (9) Note: The EEPROM WRITE bit must be sent last. This ensures that the content of all internal registers are stored in the EEPROM. The EEWRITE cycle is initiated with the rising edge of the EEWRITE bit. A static level high does not trigger an EEPROM WRITE cycle. The EEWRITE bit has to be reset to low after the programming is completed. The programming status can be monitored by reading out EEPIP. If EELOCK is set to high, no EEPROM programming is possible.

Table 9. Generic Configuration Register (continued)

Offset ⁽¹⁾	Bit ⁽²⁾	Acronym	Default ⁽³⁾	Description
07h-0Fh		—	0h	Unused address range

Table 10. PLL1 Configuration Register

OFFSET ⁽¹⁾	Bit ⁽²⁾	Acronym	Default ⁽³⁾	DESCRIPTION																		
10h	7:5	SSC1_7 [2:0]	000b	SSC1: PLL1 SSC Selection (Modulation Amount) ⁽⁴⁾ <table border="0"> <tr> <td>Down</td> <td>Center</td> </tr> <tr> <td>000 (off)</td> <td>000 (off)</td> </tr> <tr> <td>001 – 0.25%</td> <td>001 ± 0.25%</td> </tr> <tr> <td>010 – 0.5%</td> <td>010 ± 0.5%</td> </tr> <tr> <td>011 – 0.75%</td> <td>011 ± 0.75%</td> </tr> <tr> <td>100 – 1.0%</td> <td>100 ± 1.0%</td> </tr> <tr> <td>101 – 1.25%</td> <td>101 ± 1.25%</td> </tr> <tr> <td>110 – 1.5%</td> <td>110 ± 1.5%</td> </tr> <tr> <td>111 – 2.0%</td> <td>111 ± 2.0%</td> </tr> </table>	Down	Center	000 (off)	000 (off)	001 – 0.25%	001 ± 0.25%	010 – 0.5%	010 ± 0.5%	011 – 0.75%	011 ± 0.75%	100 – 1.0%	100 ± 1.0%	101 – 1.25%	101 ± 1.25%	110 – 1.5%	110 ± 1.5%	111 – 2.0%	111 ± 2.0%
	Down	Center																				
	000 (off)	000 (off)																				
001 – 0.25%	001 ± 0.25%																					
010 – 0.5%	010 ± 0.5%																					
011 – 0.75%	011 ± 0.75%																					
100 – 1.0%	100 ± 1.0%																					
101 – 1.25%	101 ± 1.25%																					
110 – 1.5%	110 ± 1.5%																					
111 – 2.0%	111 ± 2.0%																					
4:2	SSC1_6 [2:0]	000b																				
1:0	SSC1_5 [2:1]	000b																				
11h	7	SSC1_5 [0]	000b																			
	6:4	SSC1_4 [2:0]		000b																		
	3:1	SSC1_3 [2:0]		000b																		
12h	0	SSC1_2 [2]	000b																			
	7:6	SSC1_2 [1:0]		000b																		
	5:3	SSC1_1 [2:0]		000b																		
13h	2:0	SSC1_0 [2:0]	000b																			
	7	FS1_7	0b	FS1_x: PLL1 Frequency Selection ⁽⁴⁾ 0 – f _{VC01_0} (predefined by PLL1_0 – Multiplier/Divider value) 1 – f _{VC01_1} (predefined by PLL1_1 – Multiplier/Divider value)																		
	6	FS1_6	0b																			
	5	FS1_5	0b																			
	4	FS1_4	0b																			
	3	FS1_3	0b																			
	2	FS1_2	0b																			
	1	FS1_1	0b																			
0	FS1_0	0b																				
14h	7	MUX1	1b	PLL1 Multiplexer: 0 – PLL1 1 – PLL1 Bypass (PLL1 is in power down)																		
	6	M2	1b	Output Y2 Multiplexer: 0 – Pdiv1 1 – Pdiv2																		
	5:4	M3	10b	Output Y3 Multiplexer: 00 – Pdiv1-Divider 01 – Pdiv2-Divider 10 – Pdiv3-Divider 11 – reserved																		
	3:2	Y2Y3_ST1	11b	Y2, Y3-State0/1 definition: 00 – Y2/Y3 disabled to 3-State (PLL1 is in power down) 01 – Y2/Y3 disabled to 3-State 10 – Y2/Y3 disabled to low 11 – Y2/Y3 enabled																		
	1:0	Y2Y3_ST0	01b																			
15h	7	Y2Y3_7	0b	Y2Y3_x Output State Selection ⁽⁴⁾ 0 – state0 (predefined by Y2Y3_ST0) 1 – state1 (predefined by Y2Y3_ST1)																		
	6	Y2Y3_6	0b																			
	5	Y2Y3_5	0b																			
	4	Y2Y3_4	0b																			
	3	Y2Y3_3	0b																			
	2	Y2Y3_2	0b																			
	1	Y2Y3_1	1b																			
	0	Y2Y3_0	0b																			

(1) Writing data beyond 40h may adversely affect device function.

(2) All data is transferred MSB-first.

(3) Unless a custom setting is used

(4) The user can predefine up to eight different control settings. In normal device operation, these settings can be selected by the external control pins, S0, S1, and S2.

CDCE937-Q1
CDCEL937-Q1



SCAS892B –FEBRUARY 2010–REVISED MAY 2010

www.ti.com

Table 10. PLL1 Configuration Register (continued)

OFFSET ⁽¹⁾	Bit ⁽²⁾	Acronym	Default ⁽³⁾	DESCRIPTION	
16h	7	SSC1DC	0b	PLL1 SSC down/center selection: 0 – down 1 – center	
	6:0	Pdiv2	01h	7-Bit Y2-Output-Divider Pdiv2: 0 – reset and stand-by 1-to-127 is divider value	
17h	7	—	0b	Reserved – do not write others than 0	
	6:0	Pdiv3	01h	7-Bit Y3-Output-Divider Pdiv3: 0 – reset and stand-by 1-to-127 is divider value	
18h	7:0	PLL1_0N [11:4]	004h	PLL1_0: 30-Bit Multiplier/Divider value for frequency f_{VCO1_0} (for more information, see paragraph <i>PLL Multiplier/Divider Definition</i>).	
19h	7:4	PLL1_0N [3:0]			
	3:0	PLL1_0R [8:5]			
1Ah	7:3	PLL1_0R[4:0]			000h
	2:0	PLL1_0Q [5:3]			10h
1Bh	7:5	PLL1_0Q [2:0]			010b
	4:2	PLL1_0P [2:0]	010b		
1Bh	1:0	VCO1_0_RANGE	00b	f_{VCO1_0} range selection: 00 – $f_{VCO1_0} < 125$ MHz 01 – 125 MHz $\leq f_{VCO1_0} < 150$ MHz 10 – 150 MHz $\leq f_{VCO1_0} < 175$ MHz 11 – $f_{VCO1_0} \geq 175$ MHz	
1Ch	7:0	PLL1_1N [11:4]	004h	PLL1_1: 30-Bit Multiplier/Divider value for frequency f_{VCO1_1} (for more information see paragraph <i>PLL Multiplier/Divider Definition</i>)	
1Dh	7:4	PLL1_1N [3:0]			
	3:0	PLL1_1R [8:5]			
1Eh	7:3	PLL1_1R[4:0]			000h
	2:0	PLL1_1Q [5:3]			10h
1Fh	7:5	PLL1_1Q [2:0]			010b
	4:2	PLL1_1P [2:0]	010b		
1Fh	1:0	VCO1_1_RANGE	00b	f_{VCO1_1} range selection: 00 – $f_{VCO1_1} < 125$ MHz 01 – 125 MHz $\leq f_{VCO1_1} < 150$ MHz 10 – 150 MHz $\leq f_{VCO1_1} < 175$ MHz 11 – $f_{VCO1_1} \geq 175$ MHz	

Table 11. PLL2 Configuration Register

OFFSET ⁽¹⁾	Bit ⁽²⁾	Acronym	Default ⁽³⁾	DESCRIPTION																		
20h	7:5	SSC2_7 [2:0]	000b	SSC2: PLL2 SSC Selection (Modulation Amount) ⁽⁴⁾ <table border="0"> <tr> <td>Down</td> <td>Center</td> </tr> <tr> <td>000 (off)</td> <td>000 (off)</td> </tr> <tr> <td>001 – 0.25%</td> <td>001 ± 0.25%</td> </tr> <tr> <td>010 – 0.5%</td> <td>010 ± 0.5%</td> </tr> <tr> <td>011 – 0.75%</td> <td>011 ± 0.75%</td> </tr> <tr> <td>100 – 1.0%</td> <td>100 ± 1.0%</td> </tr> <tr> <td>101 – 1.25%</td> <td>101 ± 1.25%</td> </tr> <tr> <td>110 – 1.5%</td> <td>110 ± 1.5%</td> </tr> <tr> <td>111 – 2.0%</td> <td>111 ± 2.0%</td> </tr> </table>	Down	Center	000 (off)	000 (off)	001 – 0.25%	001 ± 0.25%	010 – 0.5%	010 ± 0.5%	011 – 0.75%	011 ± 0.75%	100 – 1.0%	100 ± 1.0%	101 – 1.25%	101 ± 1.25%	110 – 1.5%	110 ± 1.5%	111 – 2.0%	111 ± 2.0%
	Down	Center																				
	000 (off)	000 (off)																				
001 – 0.25%	001 ± 0.25%																					
010 – 0.5%	010 ± 0.5%																					
011 – 0.75%	011 ± 0.75%																					
100 – 1.0%	100 ± 1.0%																					
101 – 1.25%	101 ± 1.25%																					
110 – 1.5%	110 ± 1.5%																					
111 – 2.0%	111 ± 2.0%																					
4:2	SSC2_6 [2:0]	000b																				
1:0	SSC2_5 [2:1]	000b																				
21h	7	SSC2_5 [0]	000b																			
	6:4	SSC2_4 [2:0]																				
	3:1	SSC2_3 [2:0]																				
	0	SSC2_2 [2]																				
22h	7:6	SSC2_2 [1:0]	000b																			
	5:3	SSC2_1 [2:0]																				
	2:0	SSC2_0 [2:0]																				
23h	7	FS2_7	0b	FS2_x: PLL2 Frequency Selection ⁽⁴⁾ 0 – f_{VCO2_0} (predefined by PLL2_0 – Multiplier/Divider value) 1 – f_{VCO2_1} (predefined by PLL2_1 – Multiplier/Divider value)																		
	6	FS2_6	0b																			
	5	FS2_5	0b																			
	4	FS2_4	0b																			
	3	FS2_3	0b																			
	2	FS2_2	0b																			
	1	FS2_1	0b																			
	0	FS2_0	0b																			
24h	7	MUX2	1b	PLL2 Multiplexer: 0 – PLL2 1 – PLL2 Bypass (PLL2 is in power down)																		
	6	M4	1b	Output Y4 Multiplexer: 0 – Pdiv2 1 – Pdiv4																		
	5:4	M5	10b	Output Y5 Multiplexer: 00 – Pdiv2-Divider 01 – Pdiv4-Divider 10 – Pdiv5-Divider 11 – reserved																		
	3:2	Y4Y5_ST1	11b	Y4, Y5-State0/1definition: 00 – Y4/Y5 disabled to 3-State (PLL2 is in power down) 01 – Y4/Y5 disabled to 3-State 10 – Y4/Y5 disabled to low 11 – Y4/Y5 enabled																		
	1:0	Y4Y5_ST0	01b																			
25h	7	Y4Y5_7	0b	Y4Y5_x Output State Selection ⁽⁴⁾ 0 – state0 (predefined by Y4Y5_ST0) 1 – state1 (predefined by Y4Y5_ST1)																		
	6	Y4Y5_6	0b																			
	5	Y4Y5_5	0b																			
	4	Y4Y5_4	0b																			
	3	Y4Y5_3	0b																			
	2	Y4Y5_2	0b																			
	1	Y4Y5_1	1b																			
	0	Y4Y5_0	0b																			

- (1) Writing data beyond 40h may adversely affect device function.
- (2) All data is transferred MSB-first.
- (3) Unless a custom setting is used
- (4) The user can predefine up to eight different control settings. In normal device operation, these settings can be selected by the external control pins, S0, S1, and S2.

CDCE937-Q1
CDCEL937-Q1

SCAS892B –FEBRUARY 2010–REVISED MAY 2010

www.ti.com

Table 11. PLL2 Configuration Register (continued)

OFFSET ⁽¹⁾	Bit ⁽²⁾	Acronym	Default ⁽³⁾	DESCRIPTION
26h	7	SSC2DC	0b	PLL2 SSC down/center selection: 0 – down 1 – center
	6:0	Pdiv4	01h	7-Bit Y4-Output-Divider Pdiv4: 0 – reset and stand-by 1-to-127 – divider value
27h	7	—	0b	Reserved – do not write others than 0
	6:0	Pdiv5	01h	7-Bit Y5-Output-Divider Pdiv5: 0 – reset and stand-by 1-to-127 – divider value
28h	7:0	PLL2_0N [11:4]	004h	PLL2_0: 30-Bit Multiplier/Divider value for frequency f_{VCO2_0} (for more information see paragraph <i>PLL Multiplier/Divider Definition</i>)
29h	7:4	PLL2_0N [3:0]		
	3:0	PLL2_0R [8:5]	000h	
2Ah	7:3	PLL2_0R[4:0]	10h	
	2:0	PLL2_0Q [5:3]		
2Bh	7:5	PLL2_0Q [2:0]	010b	
	4:2	PLL2_0P [2:0]		
2Ch	7:0	VCO2_0_RANGE	00b	f_{VCO2_0} range selection: 00 – $f_{VCO2_0} < 125$ MHz 01 – $125 \text{ MHz} \leq f_{VCO2_0} < 150$ MHz 10 – $150 \text{ MHz} \leq f_{VCO2_0} < 175$ MHz 11 – $f_{VCO2_0} \geq 175$ MHz
	1:0			
2Ch	7:0	PLL2_1N [11:4]	004h	PLL2_1: 30-Bit Multiplier/Divider value for frequency f_{VCO2_1} (for more information see paragraph <i>PLL Multiplier/Divider Definition</i>)
2Dh	7:4	PLL2_1N [3:0]		
	3:0	PLL2_1R [8:5]	000h	
2Eh	7:3	PLL2_1R[4:0]	10h	
	2:0	PLL2_1Q [5:3]		
2Fh	7:5	PLL2_1Q [2:0]	010b	
	4:2	PLL2_1P [2:0]		
2Fh	7:0	VCO2_1_RANGE	00b	f_{VCO2_1} range selection: 00 – $f_{VCO2_1} < 125$ MHz 01 – $125 \text{ MHz} \leq f_{VCO2_1} < 150$ MHz 10 – $150 \text{ MHz} \leq f_{VCO2_1} < 175$ MHz 11 – $f_{VCO2_1} \geq 175$ MHz
	1:0			

Table 12. PLL3 Configuration Register

OFFSET ⁽¹⁾	Bit ⁽²⁾	Acronym	Default ⁽³⁾	DESCRIPTION																		
30h	7:5	SSC3_7 [2:0]	000b	SSC3: PLL3 SSC Selection (Modulation Amount) ⁽⁴⁾ <table border="0"> <tr> <td>Down</td> <td>Center</td> </tr> <tr> <td>000 (off)</td> <td>000 (off)</td> </tr> <tr> <td>001 – 0.25%</td> <td>001 ± 0.25%</td> </tr> <tr> <td>010 – 0.5%</td> <td>010 ± 0.5%</td> </tr> <tr> <td>011 – 0.75%</td> <td>011 ± 0.75%</td> </tr> <tr> <td>100 – 1.0%</td> <td>100 ± 1.0%</td> </tr> <tr> <td>101 – 1.25%</td> <td>101 ± 1.25%</td> </tr> <tr> <td>110 – 1.5%</td> <td>110 ± 1.5%</td> </tr> <tr> <td>111 – 2.0%</td> <td>111 ± 2.0%</td> </tr> </table>	Down	Center	000 (off)	000 (off)	001 – 0.25%	001 ± 0.25%	010 – 0.5%	010 ± 0.5%	011 – 0.75%	011 ± 0.75%	100 – 1.0%	100 ± 1.0%	101 – 1.25%	101 ± 1.25%	110 – 1.5%	110 ± 1.5%	111 – 2.0%	111 ± 2.0%
	Down	Center																				
	000 (off)	000 (off)																				
001 – 0.25%	001 ± 0.25%																					
010 – 0.5%	010 ± 0.5%																					
011 – 0.75%	011 ± 0.75%																					
100 – 1.0%	100 ± 1.0%																					
101 – 1.25%	101 ± 1.25%																					
110 – 1.5%	110 ± 1.5%																					
111 – 2.0%	111 ± 2.0%																					
4:2	SSC3_6 [2:0]	000b																				
1:0	SSC3_5 [2:1]	000b																				
31h	7	SSC3_5 [0]	000b																			
	6:4	SSC3_4 [2:0]	000b																			
	3:1	SSC3_3 [2:0]	000b																			
32h	0	SSC3_2 [2]	000b																			
	7:6	SSC3_2 [1:0]	000b																			
	5:3	SSC3_1 [2:0]	000b																			
33h	2:0	SSC3_0 [2:0]	000b																			
	7	FS3_7	0b	FS3_x: PLL3 Frequency Selection ⁽⁴⁾ 0 – f_{VCO3_0} (predefined by PLL3_0 – Multiplier/Divider value) 1 – f_{VCO3_1} (predefined by PLL3_1 – Multiplier/Divider value)																		
	6	FS3_6	0b																			
	5	FS3_5	0b																			
	4	FS3_4	0b																			
	3	FS3_3	0b																			
	2	FS3_2	0b																			
	1	FS3_1	0b																			
0	FS3_0	0b																				
34h	7	MUX3	1b	PLL3 Multiplexer: 0 – PLL3 1 – PLL3 Bypass (PLL3 is in power down)																		
	6	M6	1b	Output Y6 Multiplexer: 0 – Pdiv4 1 – Pdiv6																		
	5:4	M7	10b	Output Y7 Multiplexer: 00 – Pdiv4-Divider 01 – Pdiv6-Divider 10 – Pdiv7-Divider 11 – reserved																		
	3:2	Y6Y7_ST1	11b	Y6, Y7-State0/1definition: 00 – Y6/Y7 disabled to 3-State and PLL3 power down 01 – Y6/Y7 disabled to 3-State 10 – Y6/Y7 disabled to low 11 – Y6/Y7 enabled																		
	1:0	Y6Y7_ST0	01b																			
35h	7	Y6Y7_7	0b	Y6Y7_x Output State Selection ⁽⁴⁾ 0 – state0 (predefined by Y6Y7_ST0) 1 – state1 (predefined by Y6Y7_ST1)																		
	6	Y6Y7_6	0b																			
	5	Y6Y7_5	0b																			
	4	Y6Y7_4	0b																			
	3	Y6Y7_3	0b																			
	2	Y6Y7_2	0b																			
	1	Y6Y7_1	1b																			
0	Y6Y7_0	0b																				

- (1) Writing data beyond 40h may affect device function.
- (2) All data is transferred MSB-first.
- (3) Unless a custom setting is used
- (4) These are the bits of the *Control Terminal Register*. The user can pre-define up to eight different control settings. At normal device operation, these setting can be selected by the external control pins, S0, S1, and S2.

CDCE937-Q1
CDCEL937-Q1

SCAS892B –FEBRUARY 2010–REVISED MAY 2010

www.ti.com

Table 12. PLL3 Configuration Register (continued)

OFFSET ⁽¹⁾	Bit ⁽²⁾	Acronym	Default ⁽³⁾	DESCRIPTION
36h	7	SSC3DC	0b	PLL3 SSC down/center selection: 0 – down 1 – center
	6:0	Pdiv6	01h	7-Bit Y6-Output-Divider Pdiv6: 0 – reset and stand-by 1-to-127 – divider value
37h	7	—	0b	Reserved – do not write others than 0
	6:0	Pdiv7	01h	7-Bit Y7-Output-Divider Pdiv7: 0 – reset and stand-by 1-to-127 – divider value
38h	7:0	PLL3_0N [11:4]	004h	PLL3_0: 30-Bit Multiplier/Divider value for frequency f_{VCO3_0} (for more information see paragraph <i>PLL Multiplier/Divider Definition</i>)
39h	7:4	PLL3_0N [3:0]		
	3Ah	3:0	PLL3_0R [8:5]	000h
7:3		PLL3_0R[4:0]	10h	
2:0		PLL3_0Q [5:3]		
3Bh	7:5	PLL3_0Q [2:0]	010b	f_{VCO3_0} range selection: 00 – $f_{VCO3_0} < 125$ MHz 01 – $125 \text{ MHz} \leq f_{VCO3_0} < 150$ MHz 10 – $150 \text{ MHz} \leq f_{VCO3_0} < 175$ MHz 11 – $f_{VCO3_0} \geq 175$ MHz
	4:2	PLL3_0P [2:0]		
	1:0	VCO3_0_RANGE	00b	
3Ch	7:0	PLL3_1N [11:4]	004h	PLL3_1: 30-Bit Multiplier/Divider value for frequency f_{VCO3_1} (for more information see paragraph <i>PLL Multiplier/Divider Definition</i>)
3Dh	7:4	PLL3_1N [3:0]		
	3Eh	3:0	PLL3_1R [8:5]	000h
7:3		PLL3_1R[4:0]	10h	
2:0		PLL3_1Q [5:3]		
3Fh	7:5	PLL3_1Q [2:0]	010b	f_{VCO3_1} range selection: 00 – $f_{VCO3_1} < 125$ MHz 01 – $125 \text{ MHz} \leq f_{VCO3_1} < 150$ MHz 10 – $150 \text{ MHz} \leq f_{VCO3_1} < 175$ MHz 11 – $f_{VCO3_1} \geq 175$ MHz
	4:2	PLL3_1P [2:0]		
	1:0	VCO3_1_RANGE	00b	

PLL Multiplier/Divider Definition

At a given input frequency (f_{IN}), the output frequency (f_{OUT}) of the CDCE937/CDCEL937 can be calculated:

$$f_{OUT} = \frac{f_{IN}}{Pdiv} \times \frac{N}{M} \quad (1)$$

where

M (1 to 511) and N (1 to 4095) are the multiplier/divide values of the PLL;
 Pdiv (1 to 127) is the output divider.

The target VCO frequency (f_{VCO}) of each PLL can be calculated:

$$f_{VCO} = f_{IN} \times \frac{N}{M} \quad (2)$$

The PLL internally operates as fractional divider and needs the following multiplier/divider settings:

$$N$$

$$P = 4 - \text{int} \left(\log_2 \frac{N}{M} \right) \text{ [if } P < 0 \text{ then } P = 0]$$

$$Q = \text{int} \left(\frac{N'}{M} \right)$$

$$R = N' - M \times Q$$

where

$$N' = N \times 2^P$$

$$N \geq M$$

$$100 \text{ MHz} < f_{VCO} < 200 \text{ MHz}$$

Example:

for $f_{IN} = 27 \text{ MHz}$; $M = 1$; $N = 4$; $Pdiv = 2$;



- $f_{OUT} = 54 \text{ MHz}$
- $f_{VCO} = 108 \text{ MHz}$
- $P = 4 - \text{int}(\log_2 4) = 4 - 2 = 2$
- $N' = 4 \times 2^2 = 16$
- $Q = \text{int}(16) = 16$
- $R = 16 - 16 = 0$

for $f_{IN} = 27 \text{ MHz}$; $M = 2$; $N = 11$; $Pdiv = 2$;

- $f_{OUT} = 74.25 \text{ MHz}$
- $f_{VCO} = 148.50 \text{ MHz}$
- $P = 4 - \text{int}(\log_2 5.5) = 4 - 2 = 2$
- $N' = 11 \times 2^2 = 44$
- $Q = \text{int}(22) = 22$
- $R = 44 - 44 = 0$

The values for P, Q, R, and N' is automatically calculated when using TI Pro-Clock™ software.

PACKAGING INFORMATION

Orderable Device	Status (1)	Package Type	Package Drawing	Pins	Package Qty	Eco Plan (2)	Lead/Ball Finish	MSL Peak Temp (3)	Op Temp (°C)	Top-Side Markings (4)	Samples
CDCE937QPWRQ1	ACTIVE	TSSOP	PW	20	2000	Green (RoHS & no Sb/Br)	CU NIPDAU	Level-1-260C-UNLIM	-40 to 125	CDCE937Q	
CDCEL937QPWRQ1	ACTIVE	TSSOP	PW	20	2000	Green (RoHS & no Sb/Br)	CU NIPDAU	Level-1-260C-UNLIM	-40 to 125	CEL937Q	

(1) The marketing status values are defined as follows:

ACTIVE: Product device recommended for new designs.

LIFEBUY: TI has announced that the device will be discontinued, and a lifetime-buy period is in effect.

NRND: Not recommended for new designs. Device is in production to support existing customers, but TI does not recommend using this part in a new design.

PREVIEW: Device has been announced but is not in production. Samples may or may not be available.

OBSOLETE: TI has discontinued the production of the device.

(2) Eco Plan - The planned eco-friendly classification: Pb-Free (RoHS), Pb-Free (RoHS Exempt), or Green (RoHS & no Sb/Br) - please check <http://www.ti.com/productcontent> for the latest availability information and additional product content details.

TBD: The Pb-Free/Green conversion plan has not been defined.

Pb-Free (RoHS): TI's terms "Lead-Free" or "Pb-Free" mean semiconductor products that are compatible with the current RoHS requirements for all 6 substances, including the requirement that lead not exceed 0.1% by weight in homogeneous materials. Where designed to be soldered at high temperatures, TI Pb-Free products are suitable for use in specified lead-free processes.

Pb-Free (RoHS Exempt): This component has a RoHS exemption for either 1) lead-based flip-chip solder bumps used between the die and package, or 2) lead-based die adhesive used between the die and leadframe. The component is otherwise considered Pb-Free (RoHS compatible) as defined above.

Green (RoHS & no Sb/Br): TI defines "Green" to mean Pb-Free (RoHS compatible), and free of Bromine (Br) and Antimony (Sb) based flame retardants (Br or Sb do not exceed 0.1% by weight in homogeneous material)

(3) MSL, Peak Temp. -- The Moisture Sensitivity Level rating according to the JEDEC industry standard classifications, and peak solder temperature.

(4) Multiple Top-Side Markings will be inside parentheses. Only one Top-Side Marking contained in parentheses and separated by a "-" will appear on a device. If a line is indented then it is a continuation of the previous line and the two combined represent the entire Top-Side Marking for that device.

Important Information and Disclaimer: The information provided on this page represents TI's knowledge and belief as of the date that it is provided. TI bases its knowledge and belief on information provided by third parties, and makes no representation or warranty as to the accuracy of such information. Efforts are underway to better integrate information from third parties. TI has taken and continues to take reasonable steps to provide representative and accurate information but may not have conducted destructive testing or chemical analysis on incoming materials and chemicals. TI and TI suppliers consider certain information to be proprietary, and thus CAS numbers and other limited information may not be available for release.

In no event shall TI's liability arising out of such information exceed the total purchase price of the TI part(s) at issue in this document sold by TI to Customer on an annual basis.

OTHER QUALIFIED VERSIONS OF CDCE937-Q1, CDCEL937-Q1 :



Distributor of Texas Instruments: Excellent Integrated System Limited

Datasheet of CDCE937QPWRQ1 - IC 3PLL VCXO CLK SYNTH 20TSSOP

Contact us: sales@integrated-circuit.com Website: www.integrated-circuit.com

PACKAGE OPTION ADDENDUM

www.ti.com

11-Apr-2013

● Catalog: [CDCE937](#), [CDCEL937](#)

NOTE: Qualified Version Definitions:

- Catalog - TI's standard catalog product

TAPE AND REEL INFORMATION

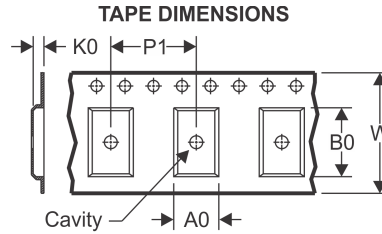
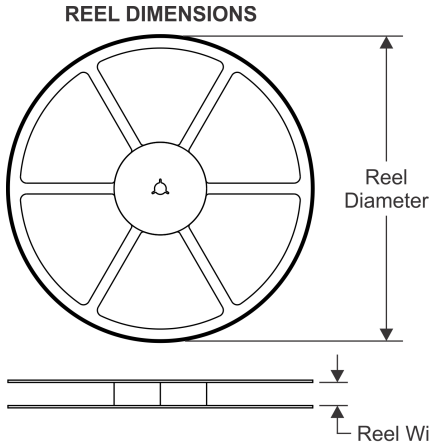

A0	Dimension designed to accommodate the component width
B0	Dimension designed to accommodate the component length
K0	Dimension designed to accommodate the component thickness
W	Overall width of the carrier tape
P1	Pitch between successive cavity centers

QUADRANT ASSIGNMENTS FOR PIN 1 ORIENTATION IN TAPE

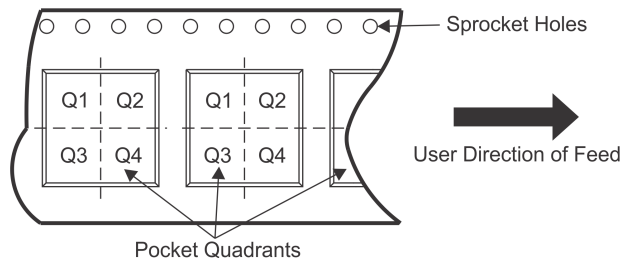

*All dimensions are nominal

Device	Package Type	Package Drawing	Pins	SPQ	Reel Diameter (mm)	Reel Width W1 (mm)	A0 (mm)	B0 (mm)	K0 (mm)	P1 (mm)	W (mm)	Pin1 Quadrant
CDCE937QPWRQ1	TSSOP	PW	20	2000	330.0	16.4	6.95	7.1	1.6	8.0	16.0	Q1
CDCEL937QPWRQ1	TSSOP	PW	20	2000	330.0	16.4	6.95	7.1	1.6	8.0	16.0	Q1

TAPE AND REEL BOX DIMENSIONS

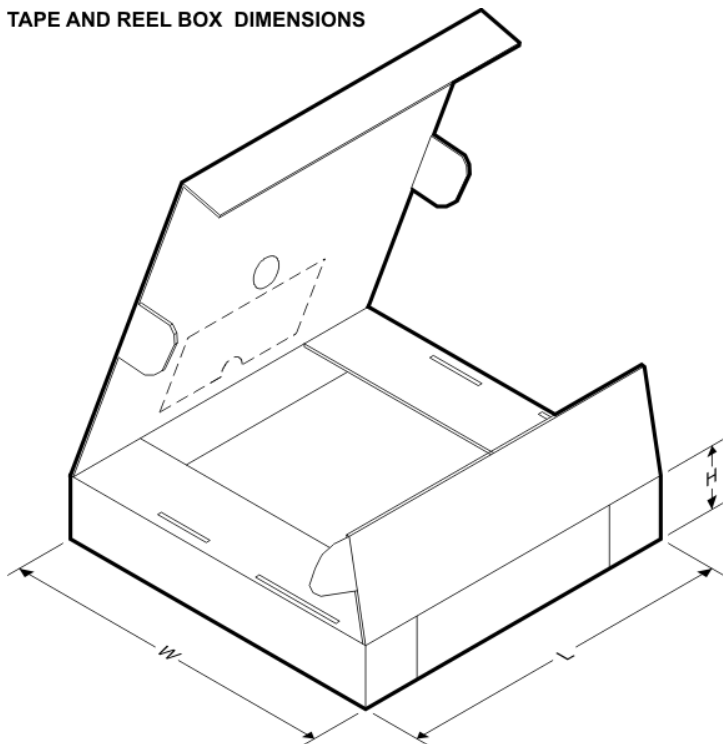

*All dimensions are nominal

Device	Package Type	Package Drawing	Pins	SPQ	Length (mm)	Width (mm)	Height (mm)
CDCE937QPWRQ1	TSSOP	PW	20	2000	367.0	367.0	38.0
CDCEL937QPWRQ1	TSSOP	PW	20	2000	367.0	367.0	38.0

MECHANICAL DATA

PW (R-PDSO-G20)

PLASTIC SMALL OUTLINE

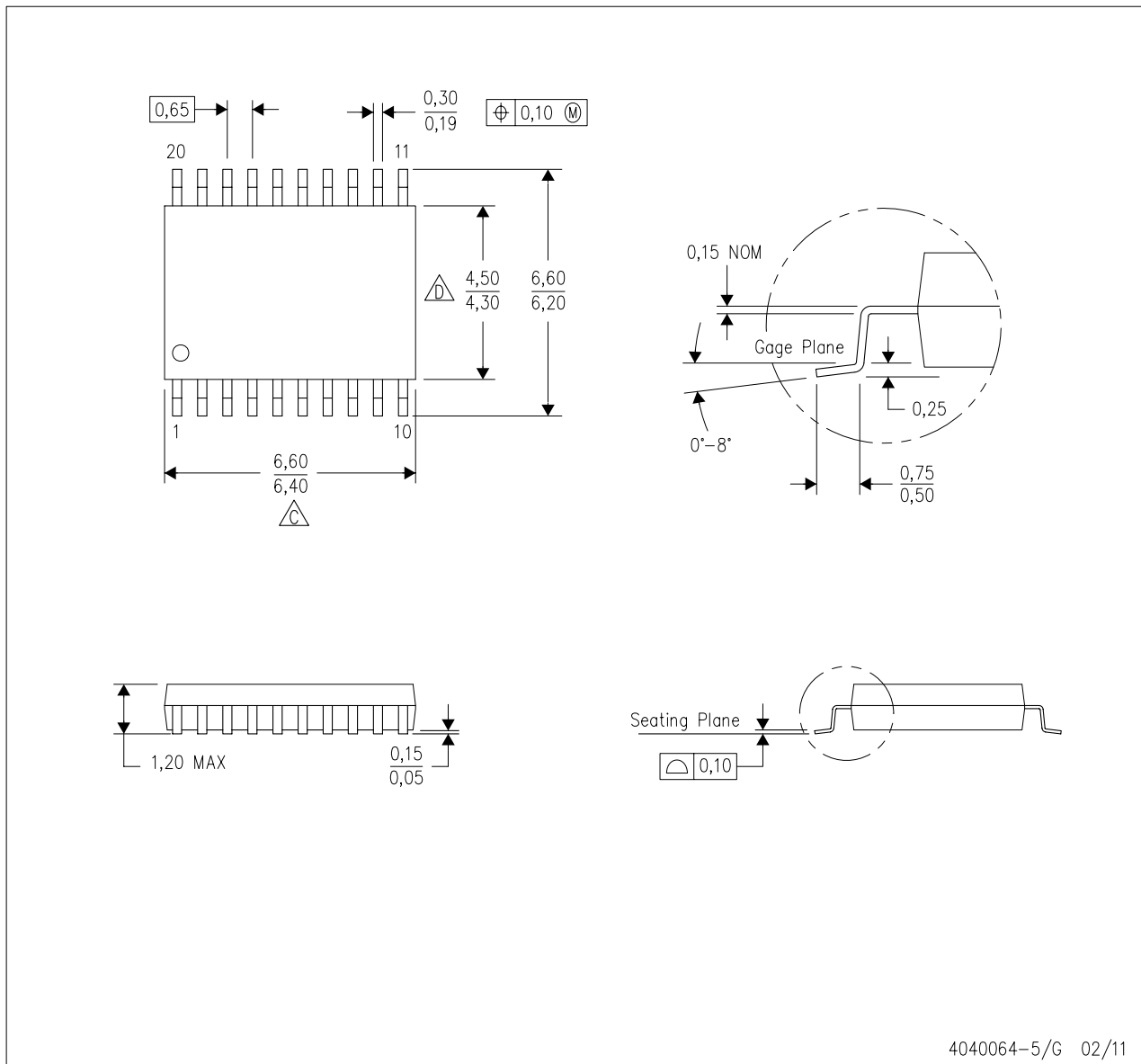

4040064-5/G 02/11

- NOTES:
- A. All linear dimensions are in millimeters. Dimensioning and tolerancing per ASME Y14.5M-1994.
 - B. This drawing is subject to change without notice.
 - C. Body length does not include mold flash, protrusions, or gate burrs. Mold flash, protrusions, or gate burrs shall not exceed 0,15 each side.
 - D. Body width does not include interlead flash. Interlead flash shall not exceed 0,25 each side.
 - E. Falls within JEDEC MO-153

LAND PATTERN DATA

PW (R-PDSO-G20)

PLASTIC SMALL OUTLINE

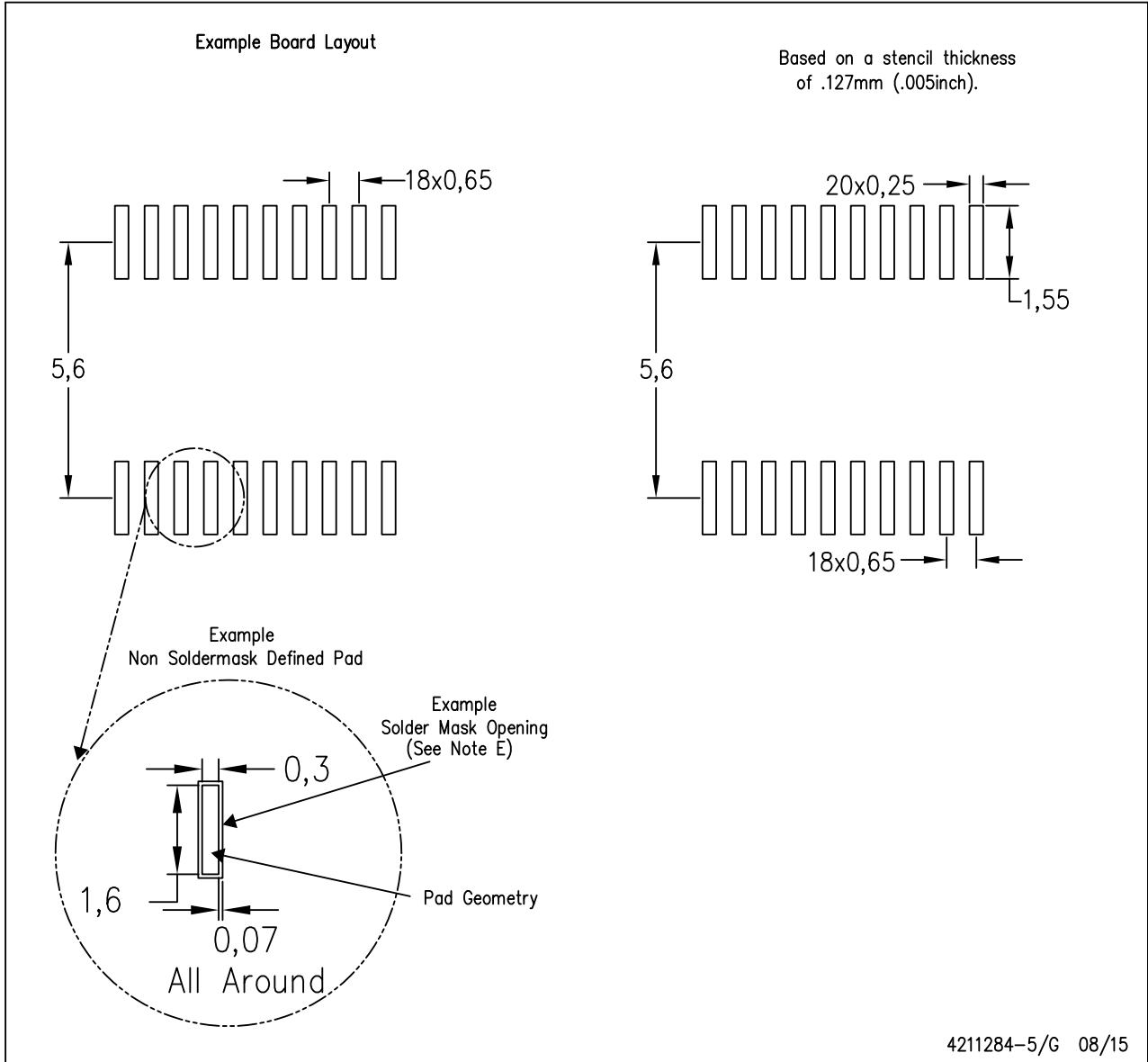

- NOTES:
- A. All linear dimensions are in millimeters.
 - B. This drawing is subject to change without notice.
 - C. Publication IPC-7351 is recommended for alternate design.
 - D. Laser cutting apertures with trapezoidal walls and also rounding corners will offer better paste release. Customers should contact their board assembly site for stencil design recommendations. Refer to IPC-7525 for other stencil recommendations.
 - E. Customers should contact their board fabrication site for solder mask tolerances between and around signal pads.

IMPORTANT NOTICE

Texas Instruments Incorporated and its subsidiaries (TI) reserve the right to make corrections, enhancements, improvements and other changes to its semiconductor products and services per JESD46, latest issue, and to discontinue any product or service per JESD48, latest issue. Buyers should obtain the latest relevant information before placing orders and should verify that such information is current and complete. All semiconductor products (also referred to herein as “components”) are sold subject to TI’s terms and conditions of sale supplied at the time of order acknowledgment.

TI warrants performance of its components to the specifications applicable at the time of sale, in accordance with the warranty in TI’s terms and conditions of sale of semiconductor products. Testing and other quality control techniques are used to the extent TI deems necessary to support this warranty. Except where mandated by applicable law, testing of all parameters of each component is not necessarily performed.

TI assumes no liability for applications assistance or the design of Buyers’ products. Buyers are responsible for their products and applications using TI components. To minimize the risks associated with Buyers’ products and applications, Buyers should provide adequate design and operating safeguards.

TI does not warrant or represent that any license, either express or implied, is granted under any patent right, copyright, mask work right, or other intellectual property right relating to any combination, machine, or process in which TI components or services are used. Information published by TI regarding third-party products or services does not constitute a license to use such products or services or a warranty or endorsement thereof. Use of such information may require a license from a third party under the patents or other intellectual property of the third party, or a license from TI under the patents or other intellectual property of TI.

Reproduction of significant portions of TI information in TI data books or data sheets is permissible only if reproduction is without alteration and is accompanied by all associated warranties, conditions, limitations, and notices. TI is not responsible or liable for such altered documentation. Information of third parties may be subject to additional restrictions.

Resale of TI components or services with statements different from or beyond the parameters stated by TI for that component or service voids all express and any implied warranties for the associated TI component or service and is an unfair and deceptive business practice. TI is not responsible or liable for any such statements.

Buyer acknowledges and agrees that it is solely responsible for compliance with all legal, regulatory and safety-related requirements concerning its products, and any use of TI components in its applications, notwithstanding any applications-related information or support that may be provided by TI. Buyer represents and agrees that it has all the necessary expertise to create and implement safeguards which anticipate dangerous consequences of failures, monitor failures and their consequences, lessen the likelihood of failures that might cause harm and take appropriate remedial actions. Buyer will fully indemnify TI and its representatives against any damages arising out of the use of any TI components in safety-critical applications.

In some cases, TI components may be promoted specifically to facilitate safety-related applications. With such components, TI’s goal is to help enable customers to design and create their own end-product solutions that meet applicable functional safety standards and requirements. Nonetheless, such components are subject to these terms.

No TI components are authorized for use in FDA Class III (or similar life-critical medical equipment) unless authorized officers of the parties have executed a special agreement specifically governing such use.

Only those TI components which TI has specifically designated as military grade or “enhanced plastic” are designed and intended for use in military/aerospace applications or environments. Buyer acknowledges and agrees that any military or aerospace use of TI components which have **not** been so designated is solely at the Buyer’s risk, and that Buyer is solely responsible for compliance with all legal and regulatory requirements in connection with such use.

TI has specifically designated certain components as meeting ISO/TS16949 requirements, mainly for automotive use. In any case of use of non-designated products, TI will not be responsible for any failure to meet ISO/TS16949.

Products

Audio	www.ti.com/audio
Amplifiers	amplifier.ti.com
Data Converters	dataconverter.ti.com
DLP® Products	www.dlp.com
DSP	dsp.ti.com
Clocks and Timers	www.ti.com/clocks
Interface	interface.ti.com
Logic	logic.ti.com
Power Mgmt	power.ti.com
Microcontrollers	microcontroller.ti.com
RFID	www.ti-rfid.com
OMAP Applications Processors	www.ti.com/omap
Wireless Connectivity	www.ti.com/wirelessconnectivity

Applications

Automotive and Transportation	www.ti.com/automotive
Communications and Telecom	www.ti.com/communications
Computers and Peripherals	www.ti.com/computers
Consumer Electronics	www.ti.com/consumer-apps
Energy and Lighting	www.ti.com/energy
Industrial	www.ti.com/industrial
Medical	www.ti.com/medical
Security	www.ti.com/security
Space, Avionics and Defense	www.ti.com/space-avionics-defense
Video and Imaging	www.ti.com/video

TI E2E Community

e2e.ti.com