

## Excellent Integrated System Limited

Stocking Distributor

Click to view price, real time Inventory, Delivery & Lifecycle Information:

[Analog Devices Inc.](#)  
[ADG1606BRUZ](#)

For any questions, you can email us directly:

[sales@integrated-circuit.com](mailto:sales@integrated-circuit.com)



# 4.5 $\Omega$ $R_{ON}$ , 16-Channel, Differential 8-Channel, $\pm 5$ V, +12 V, +5 V, and +3.3 V Multiplexers

## ADG1606/ADG1607

### FEATURES

- 4.5  $\Omega$  typical on resistance
- 1.1  $\Omega$  on resistance flatness
- $\pm 3.3$  V to  $\pm 8$  V dual supply operation
- 3.3 V to 16 V single supply operation
- No  $V_L$  supply required
- 3 V logic-compatible inputs
- Rail-to-rail operation
- Up to 378 mA of continuous current per channel
- 28-lead TSSOP and 32-lead, 5 mm  $\times$  5 mm LFCSP\_VQ

### APPLICATIONS

- Communication systems
- Medical systems
- Audio signal routing
- Video signal routing
- Automatic test equipment
- Data acquisition systems
- Battery-powered systems
- Sample-and-hold systems
- Relay replacements

### GENERAL DESCRIPTION

The ADG1606 and ADG1607 are monolithic *i*CMOS<sup>®</sup> analog multiplexers comprising of 16 single channels and eight differential channels, respectively. The ADG1606 switches one of 16 inputs to a common output, as determined by the 4-bit binary address lines (A0, A1, A2, and A3). The ADG1607 switches one of eight differential inputs to a common differential output, as determined by the 3-bit binary address lines (A0, A1, and A2). An EN input on both devices enables or disables the device. When disabled, all channels switch off. When enabled, each channel conducts equally well in both directions and has an input signal range that extends to the supplies.

The ultralow on resistance and on-resistance flatness of these switches make them ideal solutions for data acquisition and gain switching applications where low distortion is critical. *i*CMOS<sup>®</sup> construction ensures ultralow power dissipation, making the parts ideally suited for portable and battery-powered instruments.

### FUNCTIONAL BLOCK DIAGRAMS

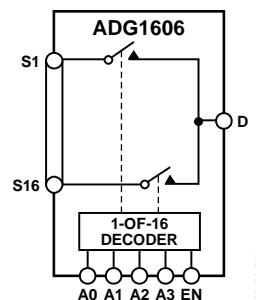

Figure 1.

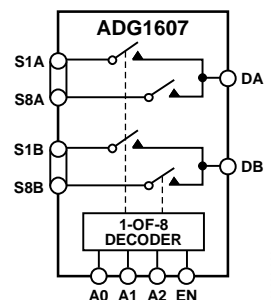

Figure 2.

### PRODUCT HIGHLIGHTS

1. 7.5  $\Omega$  maximum on resistance over temperature.
2. Minimum distortion: THD + N = 0.04%
3. 3 V logic-compatible digital inputs:  $V_{INH} = 2.0$  V,  $V_{INL} = 0.8$  V.
4. No  $V_L$  logic power supply required.

#### Rev. 0

Information furnished by Analog Devices is believed to be accurate and reliable. However, no responsibility is assumed by Analog Devices for its use, nor for any infringements of patents or other rights of third parties that may result from its use. Specifications subject to change without notice. No license is granted by implication or otherwise under any patent or patent rights of Analog Devices. Trademarks and registered trademarks are the property of their respective owners.

## ADG1606/ADG1607

### TABLE OF CONTENTS

|                                 |   |  |    |
|---------------------------------|---|--|----|
| Features .....                  | 1 | Continuous Current per Channel, S or D .....       | 7  |
| Applications .....              | 1 | Absolute Maximum Ratings .....                     | 8  |
| Functional Block Diagrams ..... | 1 | Thermal Resistance .....                           | 8  |
| General Description .....       | 1 | ESD Caution .....                                  | 8  |
| Product Highlights .....        | 1 | Pin Configurations and Function Descriptions ..... | 9  |
| Revision History .....          | 2 | Typical Performance Characteristics .....          | 13 |
| Specifications .....            | 3 | Test Circuits .....                                | 17 |
| $\pm 5$ V Dual Supply .....     | 3 | Terminology .....                                  | 20 |
| 12 V Single Supply .....        | 4 | Outline Dimensions .....                           | 21 |
| 5 V Single Supply .....         | 5 | Ordering Guide .....                               | 21 |
| 3.3 V Single Supply .....       | 6 |  |    |

### REVISION HISTORY

10/09—Revision 0: Initial Version

## SPECIFICATIONS

### ±5 V DUAL SUPPLY

$V_{DD} = +5\text{ V} \pm 10\%$ ,  $V_{SS} = -5\text{ V} \pm 10\%$ ,  $GND = 0\text{ V}$ , unless otherwise noted.

**Table 1.**

| Parameter  | 25°C        | -40°C to +85°C | -40°C to +125°C      | Unit              | Test Conditions/Comments   |
|--|-------------|----------------|----------------------|-------------------|--|
| <b>ANALOG SWITCH</b>                                     |             |                |                      |                   |  |
| Analog Signal Range                                      |             |                | $V_{DD}$ to $V_{SS}$ | V                 |  |
| On Resistance ( $R_{ON}$ )                               | 4.5         |                |                      | $\Omega$ typ      | $V_S = \pm 4.5\text{ V}$ , $I_S = -10\text{ mA}$ ; see Figure 26                               |
|  | 5.5         | 6.7            | 7.5                  | $\Omega$ max      | $V_{DD} = \pm 4.5\text{ V}$ , $V_{SS} = \pm 4.5\text{ V}$                                      |
| On Resistance Match Between Channels ( $\Delta R_{ON}$ ) | 0.2         |                |                      | $\Omega$ typ      | $V_S = \pm 4.5\text{ V}$ , $I_S = -10\text{ mA}$   |
|  | 0.5         | 0.8            | 0.9                  | $\Omega$ max      |  |
| On Resistance Flatness ( $R_{FLAT(ON)}$ )                | 1.1         |                |                      | $\Omega$ typ      | $V_S = \pm 4.5\text{ V}$ , $I_S = -10\text{ mA}$   |
|  | 1.4         | 1.7            | 2                    | $\Omega$ max      |  |
| <b>LEAKAGE CURRENTS</b>                                  |             |                |                      |                   |  |
| Source Off Leakage, $I_S$ (Off)                          | $\pm 0.02$  |                |                      | nA typ            | $V_{DD} = +5.5\text{ V}$ , $V_{SS} = -5.5\text{ V}$  |
|  | $\pm 0.15$  | $\pm 0.5$      | $\pm 3$              | nA max            | $V_S = \pm 4.5\text{ V}$ , $V_D = \mp 4.5\text{ V}$ ; see Figure 27                            |
| Drain Off Leakage, $I_D$ (Off)                           | $\pm 0.05$  |                |                      | nA typ            | $V_S = \pm 4.5\text{ V}$ , $V_D = \mp 4.5\text{ V}$ ; see Figure 27                            |
| ADG1606  | $\pm 0.2$   | $\pm 3$        | $\pm 25$             | nA max            |  |
| Channel On Leakage, $I_D$ , $I_S$ (On)                   | $\pm 0.1$   |                |                      | nA typ            | $V_S = V_D = \pm 4.5\text{ V}$ ; see Figure 28   |
|  | $\pm 0.3$   | $\pm 3$        | $\pm 25$             | nA max            |  |
| <b>DIGITAL INPUTS</b>                                    |             |                |                      |                   |  |
| Input High Voltage, $V_{INH}$                            |             |                | 2.0                  | V min             |  |
| Input Low Voltage, $V_{INL}$                             |             |                | 0.8                  | V max             |  |
| Input Current, $I_{INL}$ or $I_{INH}$                    | $\pm 0.003$ |                |                      | $\mu\text{A}$ typ | $V_{IN} = V_{GND}$ or $V_{DD}$   |
|  |             |                | $\pm 0.1$            | $\mu\text{A}$ max |  |
| Digital Input Capacitance, $C_{IN}$                      | 4           |                |                      | pF typ            |  |
| <b>DYNAMIC CHARACTERISTICS<sup>1</sup></b>               |             |                |                      |                   |  |
| Transition Time, $t_{TRANSITION}$                        | 175         |                |                      | ns typ            | $R_L = 300\ \Omega$ , $C_L = 35\text{ pF}$   |
|  | 214         | 247            | 275                  | ns max            | $V_S = 2.5\text{ V}$ ; see Figure 29   |
| $t_{ON}$ (EN)  | 132         |                |                      | ns typ            | $R_L = 300\ \Omega$ , $C_L = 35\text{ pF}$   |
|  | 162         | 180            | 188                  | ns max            | $V_S = 2.5\text{ V}$ ; see Figure 31   |
| $t_{OFF}$ (EN)   | 124         |                |                      | ns typ            | $R_L = 300\ \Omega$ , $C_L = 35\text{ pF}$   |
|  | 153         | 176            | 202                  | ns max            | $V_S = 2.5\text{ V}$ ; see Figure 31   |
| Break-Before-Make Time Delay, $t_{BBM}$                  | 42          |                |                      | ns typ            | $R_L = 300\ \Omega$ , $C_L = 35\text{ pF}$   |
|  |             |                | 15                   | ns min            | $V_{S1} = V_{S2} = 2.5\text{ V}$ ; see Figure 30   |
| Charge Injection   | 27          |                |                      | pC typ            | $V_S = 0\text{ V}$ , $R_S = 0\ \Omega$ , $C_L = 1\text{ nF}$ ; see Figure 32                   |
| Off Isolation  | -62         |                |                      | dB typ            | $R_L = 50\ \Omega$ , $C_L = 5\text{ pF}$ , $f = 1\text{ MHz}$ ; see Figure 33                  |
| Channel-to-Channel Crosstalk                             | -62         |                |                      | dB typ            | $R_L = 50\ \Omega$ , $C_L = 5\text{ pF}$ , $f = 1\text{ MHz}$ ; see Figure 35                  |
| Total Harmonic Distortion + Noise (THD + N)              | 0.04        |                |                      | % typ             | $R_L = 110\ \Omega$ , $5\text{ V p-p}$ , $f = 20\text{ Hz}$ to $20\text{ kHz}$ ; see Figure 36 |
| -3 dB Bandwidth  |             |                |                      |                   | $R_L = 50\ \Omega$ , $C_L = 5\text{ pF}$ ; see Figure 34                                       |
| ADG1606  | 21          |                |                      | MHz typ           |  |
| ADG1607  | 37          |                |                      | MHz typ           |  |
| $C_S$ (Off)  | 18          |                |                      | pF typ            | $V_S = 0\text{ V}$ , $f = 1\text{ MHz}$  |
| $C_D$ (Off)  |             |                |                      |                   |  |
| ADG1606  | 248         |                |                      | pF typ            | $V_S = 0\text{ V}$ , $f = 1\text{ MHz}$  |
| ADG1607  | 123         |                |                      | pF typ            | $V_S = 0\text{ V}$ , $f = 1\text{ MHz}$  |
| $C_D$ , $C_S$ (On)                                       |             |                |                      |                   |  |
| ADG1606  | 271         |                |                      | pF typ            | $V_S = 0\text{ V}$ , $f = 1\text{ MHz}$  |
| ADG1607  | 146         |                |                      | pF typ            | $V_S = 0\text{ V}$ , $f = 1\text{ MHz}$  |
| <b>POWER REQUIREMENTS</b>                                |             |                |                      |                   |  |
| $I_{DD}$   | 0.001       |                |                      | $\mu\text{A}$ typ | $V_{DD} = +5.5\text{ V}$ , $V_{SS} = -5.5\text{ V}$  |
|  |             |                | 1.0                  | $\mu\text{A}$ max | Digital inputs = $0\text{ V}$ or $V_{DD}$  |
| $V_{DD}/V_{SS}$  |             |                | $\pm 3.3/\pm 8$      | V min/max         |  |

<sup>1</sup> Guaranteed by design, not subject to production test.

## ADG1606/ADG1607

### 12 V SINGLE SUPPLY

$V_{DD} = 12\text{ V} \pm 10\%$ ,  $V_{SS} = 0\text{ V}$ ,  $GND = 0\text{ V}$ , unless otherwise noted.

Table 2.

| Parameter  | 25°C        | -40°C to +85°C | -40°C to +125°C | Unit              | Test Conditions/Comments  |
|--|-------------|----------------|-----------------|-------------------|---|
| <b>ANALOG SWITCH</b>                                     |             |                |                 |                   |   |
| Analog Signal Range                                      |             |                | 0 V to $V_{DD}$ | V                 |   |
| On Resistance ( $R_{ON}$ )                               | 4           |                |                 | $\Omega$ typ      | $V_S = 0\text{ V}$ to 10 V, $I_S = -10\text{ mA}$ ; see Figure 26               |
|  |             | 6.2            | 7               | $\Omega$ max      | $V_{DD} = 10.8\text{ V}$ , $V_{SS} = 0\text{ V}$                                |
| On Resistance Match Between Channels ( $\Delta R_{ON}$ ) | 0.2         |                |                 | $\Omega$ typ      | $V_S = 10\text{ V}$ , $I_S = -10\text{ mA}$                                     |
|  | 0.5         | 0.8            | 0.9             | $\Omega$ max      |   |
| On Resistance Flatness ( $R_{FLAT(ON)}$ )                | 1           |                |                 | $\Omega$ typ      | $V_S = 0\text{ V}$ to 10 V, $I_S = -10\text{ mA}$                               |
|  | 1.3         | 1.6            | 1.9             | $\Omega$ max      |   |
| <b>LEAKAGE CURRENTS</b>                                  |             |                |                 |                   |   |
| Source Off Leakage, $I_S$ (Off)                          | $\pm 0.02$  |                |                 | nA typ            | $V_{DD} = 13.2\text{ V}$ , $V_{SS} = 0\text{ V}$                                |
|  | $\pm 0.15$  | $\pm 0.5$      | $\pm 3$         | nA max            | $V_S = 1\text{ V}/10\text{ V}$ , $V_D = 10\text{ V}/1\text{ V}$ ; see Figure 27 |
| Drain Off Leakage, $I_D$ (Off)                           | $\pm 0.05$  |                |                 | nA typ            | $V_S = 1\text{ V}/10\text{ V}$ , $V_D = 10\text{ V}/1\text{ V}$ ; see Figure 27 |
| ADG1606  | $\pm 0.2$   | $\pm 3$        | $\pm 25$        | nA max            |   |
| Channel On Leakage, $I_D$ , $I_S$ (On)                   | $\pm 0.1$   |                |                 | nA typ            | $V_S = V_D = 1\text{ V}$ or 10 V; see Figure 28                                 |
|  | $\pm 0.3$   | $\pm 3$        | $\pm 25$        | nA max            |   |
| <b>DIGITAL INPUTS</b>                                    |             |                |                 |                   |   |
| Input High Voltage, $V_{INH}$                            |             |                | 2.0             | V min             |   |
| Input Low Voltage, $V_{INL}$                             |             |                | 0.8             | V max             |   |
| Input Current, $I_{INL}$ or $I_{INH}$                    | $\pm 0.003$ |                |                 | $\mu\text{A}$ typ | $V_{IN} = V_{GND}$ or $V_{DD}$  |
|  |             |                | $\pm 0.1$       | $\mu\text{A}$ max |   |
| Digital Input Capacitance, $C_{IN}$                      | 4           |                |                 | pF typ            |   |
| <b>DYNAMIC CHARACTERISTICS<sup>1</sup></b>               |             |                |                 |                   |   |
| Transition Time, $t_{TRANSITION}$                        | 143         |                |                 | ns typ            | $R_L = 300\ \Omega$ , $C_L = 35\text{ pF}$                                      |
|  | 170         | 198            | 221             | ns max            | $V_S = 8\text{ V}$ ; see Figure 29  |
| $t_{ON}$ (EN)  | 108         |                |                 | ns typ            | $R_L = 300\ \Omega$ , $C_L = 35\text{ pF}$                                      |
|  | 128         | 136            | 142             | ns max            | $V_S = 8\text{ V}$ ; see Figure 31  |
| $t_{OFF}$ (EN)   | 90          |                |                 | ns typ            | $R_L = 300\ \Omega$ , $C_L = 35\text{ pF}$                                      |
|  | 109         | 132            | 150             | ns max            | $V_S = 8\text{ V}$ ; see Figure 31  |
| Break-Before-Make Time Delay, $t_{BBM}$                  | 40          |                |                 | ns typ            | $R_L = 300\ \Omega$ , $C_L = 35\text{ pF}$                                      |
|  |             |                | 15              | ns min            | $V_{S1} = V_{S2} = 8\text{ V}$ ; see Figure 30                                  |
| Charge Injection   | 33          |                |                 | pC typ            | $V_S = 6\text{ V}$ , $R_S = 0\ \Omega$ , $C_L = 1\text{ nF}$ ; see Figure 32    |
| Off Isolation  | -62         |                |                 | dB typ            | $R_L = 50\ \Omega$ , $C_L = 5\text{ pF}$ , $f = 1\text{ MHz}$ ; see Figure 33   |
| Channel-to-Channel Crosstalk                             | -62         |                |                 | dB typ            | $R_L = 50\ \Omega$ , $C_L = 5\text{ pF}$ , $f = 1\text{ MHz}$ ; see Figure 35   |
| Total Harmonic Distortion + Noise (THD + N)              | 0.04        |                |                 | % typ             | $R_L = 110\ \Omega$ , 5 V p-p, $f = 20\text{ Hz}$ to 20 kHz; see Figure 36      |
| -3 dB Bandwidth  |             |                |                 |                   | $R_L = 50\ \Omega$ , $C_L = 5\text{ pF}$ ; see Figure 34                        |
| ADG1606  | 22          |                |                 | MHz typ           |   |
| ADG1607  | 38          |                |                 | MHz typ           |   |
| $C_S$ (Off)  | 18          |                |                 | pF typ            | $V_S = 6\text{ V}$ , $f = 1\text{ MHz}$   |
| $C_D$ (Off)  |             |                |                 |                   |   |
| ADG1606  | 240         |                |                 | pF typ            | $V_S = 6\text{ V}$ , $f = 1\text{ MHz}$   |
| ADG1607  | 120         |                |                 | pF typ            | $V_S = 6\text{ V}$ , $f = 1\text{ MHz}$   |
| $C_D$ , $C_S$ (On)                                       |             |                |                 |                   |   |
| ADG1606  | 263         |                |                 | pF typ            | $V_S = 6\text{ V}$ , $f = 1\text{ MHz}$   |
| ADG1607  | 143         |                |                 | pF typ            | $V_S = 6\text{ V}$ , $f = 1\text{ MHz}$   |
| <b>POWER REQUIREMENTS</b>                                |             |                |                 |                   |   |
| $I_{DD}$   | 0.001       |                |                 | $\mu\text{A}$ typ | $V_{DD} = 12\text{ V}$  |
|  |             |                | 1.0             | $\mu\text{A}$ max | Digital inputs = 0 V or $V_{DD}$  |
| ADG1606  | 300         |                |                 | $\mu\text{A}$ typ | Digital inputs = 5 V  |
|  |             |                | 480             | $\mu\text{A}$ max |   |
| ADG1607  | 370         |                |                 | $\mu\text{A}$ typ | Digital inputs = 5 V  |
|  |             |                | 600             | $\mu\text{A}$ max |   |
| $V_{DD}$   |             |                | 3.3/16          | V min/max         |   |

<sup>1</sup> Guaranteed by design, not subject to production test.

## ADG1606/ADG1607

### 5 V SINGLE SUPPLY

$V_{DD} = 5\text{ V} \pm 10\%$ ,  $V_{SS} = 0\text{ V}$ ,  $GND = 0\text{ V}$ , unless otherwise noted.

Table 3.

| Parameter  | 25°C        | -40°C to +85°C | -40°C to +125°C | Unit              | Test Conditions/Comments   |
|--|-------------|----------------|-----------------|-------------------|--|
| <b>ANALOG SWITCH</b>                                     |             |                |                 |                   |  |
| Analog Signal Range                                      |             |                | 0 V to $V_{DD}$ | V                 |  |
| On Resistance ( $R_{ON}$ )                               | 8.5         |                |                 | $\Omega$ typ      | $V_S = 0\text{ V to }4.5\text{ V}$ , $I_S = -10\text{ mA}$ ; see Figure 26                           |
|  | 9.5         | 11.5           | 12.5            | $\Omega$ max      | $V_{DD} = 4.5\text{ V}$ , $V_{SS} = 0\text{ V}$  |
| On Resistance Match Between Channels ( $\Delta R_{ON}$ ) | 0.3         |                |                 | $\Omega$ typ      | $V_S = 0\text{ V to }4.5\text{ V}$ , $I_S = -10\text{ mA}$   |
|  | 0.8         | 1.1            | 1.2             | $\Omega$ max      |  |
| On Resistance Flatness ( $R_{FLAT(ON)}$ )                | 1.8         |                |                 | $\Omega$ typ      | $V_S = 0\text{ V to }4.5\text{ V}$ , $I_S = -10\text{ mA}$   |
|  | 2.4         | 2.7            | 3               | $\Omega$ max      |  |
| <b>LEAKAGE CURRENTS</b>                                  |             |                |                 |                   |  |
| Source Off Leakage, $I_S$ (Off)                          | $\pm 0.01$  |                |                 | nA typ            | $V_{DD} = 5.5\text{ V}$ , $V_{SS} = 0\text{ V}$  |
|  | $\pm 0.15$  | $\pm 0.5$      | $\pm 3$         | nA max            | $V_S = 1\text{ V}/4.5\text{ V}$ , $V_D = 4.5\text{ V}/1\text{ V}$ ; see Figure 27                    |
| Drain Off Leakage, $I_D$ (Off)                           | $\pm 0.02$  |                |                 | nA typ            | $V_S = 1\text{ V}/4.5\text{ V}$ , $V_D = 4.5\text{ V}/1\text{ V}$ ; see Figure 27                    |
| ADG1606  | $\pm 0.2$   | $\pm 3$        | $\pm 25$        | nA max            |  |
| Channel On Leakage, $I_D$ , $I_S$ (On)                   | $\pm 0.05$  |                |                 | nA typ            | $V_S = V_D = 1\text{ V or }4.5\text{ V}$ ; see Figure 28   |
|  | $\pm 0.3$   | $\pm 3$        | $\pm 25$        | nA max            |  |
| <b>DIGITAL INPUTS</b>                                    |             |                |                 |                   |  |
| Input High Voltage, $V_{INH}$                            |             |                | 2.0             | V min             |  |
| Input Low Voltage, $V_{INL}$                             |             |                | 0.8             | V max             |  |
| Input Current, $I_{INL}$ or $I_{INH}$                    | $\pm 0.003$ |                |                 | $\mu\text{A}$ typ | $V_{IN} = V_{GND}$ or $V_{DD}$   |
|  |             |                | $\pm 0.1$       | $\mu\text{A}$ max |  |
| Digital Input Capacitance, $C_{IN}$                      | 4           |                |                 | pF typ            |  |
| <b>DYNAMIC CHARACTERISTICS<sup>1</sup></b>               |             |                |                 |                   |  |
| Transition Time, $t_{TRANSITION}$                        | 220         |                |                 | ns typ            | $R_L = 300\ \Omega$ , $C_L = 35\text{ pF}$   |
|  | 280         | 324            | 360             | ns max            | $V_S = 2.5\text{ V}$ ; see Figure 29   |
| $t_{ON}$ (EN)  | 160         |                |                 | ns typ            | $R_L = 300\ \Omega$ , $C_L = 35\text{ pF}$   |
|  | 202         | 221            | 234             | ns max            | $V_S = 2.5\text{ V}$ ; see Figure 31   |
| $t_{OFF}$ (EN)   | 154         |                |                 | ns typ            | $R_L = 300\ \Omega$ , $C_L = 35\text{ pF}$   |
|  | 197         | 232            | 259             | ns max            | $V_S = 2.5\text{ V}$ ; see Figure 31   |
| Break-Before-Make Time Delay, $t_{BBM}$                  | 45          |                |                 | ns typ            | $R_L = 300\ \Omega$ , $C_L = 35\text{ pF}$   |
|  |             |                | 15              | ns min            | $V_{S1} = V_{S2} = 2.5\text{ V}$ ; see Figure 30   |
| Charge Injection   | 12          |                |                 | pC typ            | $V_S = 2.5\text{ V}$ , $R_S = 0\ \Omega$ , $C_L = 1\text{ nF}$ ; see Figure 32                       |
| Off Isolation  | -62         |                |                 | dB typ            | $R_L = 50\ \Omega$ , $C_L = 5\text{ pF}$ , $f = 1\text{ MHz}$ ; see Figure 33                        |
| Channel-to-Channel Crosstalk                             | -62         |                |                 | dB typ            | $R_L = 50\ \Omega$ , $C_L = 5\text{ pF}$ , $f = 1\text{ MHz}$ ; see Figure 35                        |
| Total Harmonic Distortion + Noise (THD + N)              | 0.35        |                |                 | % typ             | $R_L = 110\ \Omega$ , $f = 20\text{ Hz to }20\text{ kHz}$ , $V_S = 3.5\text{ V p-p}$ ; see Figure 36 |
| -3 dB Bandwidth  |             |                |                 |                   | $R_L = 50\ \Omega$ , $C_L = 5\text{ pF}$ ; see Figure 34   |
| ADG1606  | 19          |                |                 | MHz typ           |  |
| ADG1607  | 34          |                |                 | MHz typ           |  |
| $C_S$ (Off)  | 20          |                |                 | pF typ            | $V_S = 2.5\text{ V}$ , $f = 1\text{ MHz}$  |
| $C_D$ (Off)  |             |                |                 |                   |  |
| ADG1606  | 270         |                |                 | pF typ            | $V_S = 2.5\text{ V}$ , $f = 1\text{ MHz}$  |
| ADG1607  | 137         |                |                 | pF typ            | $V_S = 2.5\text{ V}$ , $f = 1\text{ MHz}$  |
| $C_D$ , $C_S$ (On)                                       |             |                |                 |                   |  |
| ADG1606  | 300         |                |                 | pF typ            | $V_S = 2.5\text{ V}$ , $f = 1\text{ MHz}$  |
| ADG1607  | 160         |                |                 | pF typ            | $V_S = 2.5\text{ V}$ , $f = 1\text{ MHz}$  |
| <b>POWER REQUIREMENTS</b>                                |             |                |                 |                   |  |
| $I_{DD}$   | 0.001       |                |                 | $\mu\text{A}$ typ | $V_{DD} = 5.5\text{ V}$  |
|  |             |                | 1.0             | $\mu\text{A}$ max | Digital inputs = 0 V or $V_{DD}$   |
| $V_{DD}$   |             |                | 3.3/16          | V min/max         |  |

<sup>1</sup> Guaranteed by design, not subject to production test.

## ADG1606/ADG1607

### 3.3 V SINGLE SUPPLY

$V_{DD} = 3.3\text{ V}$ ,  $V_{SS} = 0\text{ V}$ ,  $GND = 0\text{ V}$ , unless otherwise noted.

Table 4.

| Parameter  | 25°C        | -40°C to +85°C | -40°C to +125°C | Unit              | Test Conditions/Comments  |
|--|-------------|----------------|-----------------|-------------------|---|
| <b>ANALOG SWITCH</b>                                     |             |                |                 |                   |   |
| Analogue Signal Range                                    |             |                | 0 V to $V_{DD}$ | V                 |   |
| On Resistance ( $R_{ON}$ )                               | 14          | 14.5           | 15.5            | $\Omega$ typ      | $V_S = 0\text{ V to }V_{DD}$ , $I_S = -10\text{ mA}$ ; see Figure 26<br>$V_{DD} = 3.3\text{ V}$ , $V_{SS} = 0\text{ V}$ |
| On Resistance Match Between Channels ( $\Delta R_{ON}$ ) | 0.6         | 0.7            | 0.8             | $\Omega$ typ      | $V_S = 0\text{ V to }V_{DD}$ , $I_S = -10\text{ mA}$  |
| On Resistance Flatness ( $R_{FLAT(ON)}$ )                | 5           | 5.5            | 6               | $\Omega$ typ      | $V_S = 0\text{ V to }V_{DD}$ , $I_S = -10\text{ mA}$  |
| <b>LEAKAGE CURRENTS</b>                                  |             |                |                 |                   |   |
| Source Off Leakage, $I_S$ (Off)                          | $\pm 0.01$  |                |                 | nA typ            | $V_{DD} = 3.6\text{ V}$ , $V_{SS} = 0\text{ V}$   |
|  | $\pm 0.15$  | $\pm 0.5$      | $\pm 3$         | nA max            | $V_S = 0.6\text{ V}/3\text{ V}$ , $V_D = 3\text{ V}/0.6\text{ V}$ ; see Figure 27                                       |
| Drain Off Leakage, $I_D$ (Off)                           | $\pm 0.02$  |                |                 | nA typ            | $V_S = 0.6\text{ V}/3\text{ V}$ , $V_D = 3\text{ V}/0.6\text{ V}$ ; see Figure 27                                       |
| ADG1606  | $\pm 0.2$   | $\pm 3$        | $\pm 25$        | nA max            |   |
| Channel On Leakage, $I_D$ , $I_S$ (On)                   | $\pm 0.05$  |                |                 | nA typ            | $V_S = V_D = 0.6\text{ V or }3\text{ V}$ ; see Figure 28  |
|  | $\pm 0.3$   | $\pm 3$        | $\pm 25$        | nA max            |   |
| <b>DIGITAL INPUTS</b>                                    |             |                |                 |                   |   |
| Input High Voltage, $V_{INH}$                            |             |                | 2.0             | V min             |   |
| Input Low Voltage, $V_{INL}$                             |             |                | 0.8             | V max             |   |
| Input Current, $I_{INL}$ or $I_{INH}$                    | $\pm 0.003$ |                |                 | $\mu\text{A}$ typ | $V_{IN} = V_{GND}$ or $V_{DD}$  |
|  |             |                | $\pm 0.1$       | $\mu\text{A}$ max |   |
| Digital Input Capacitance, $C_{IN}$                      | 4           |                |                 | pF typ            |   |
| <b>DYNAMIC CHARACTERISTICS<sup>1</sup></b>               |             |                |                 |                   |   |
| Transition Time, $t_{TRANSITION}$                        | 353         |                |                 | ns typ            | $R_L = 300\ \Omega$ , $C_L = 35\text{ pF}$  |
|  | 482         | 536            | 575             | ns max            | $V_S = 1.5\text{ V}$ ; see Figure 29  |
| $t_{ON}$ (EN)  | 263         |                |                 | ns typ            | $R_L = 300\ \Omega$ , $C_L = 35\text{ pF}$  |
|  | 362         | 385            | 396             | ns max            | $V_S = 1.5\text{ V}$ ; see Figure 31  |
| $t_{OFF}$ (EN)   | 262         |                |                 | ns typ            | $R_L = 300\ \Omega$ , $C_L = 35\text{ pF}$  |
|  | 348         | 391            | 424             | ns max            | $V_S = 1.5\text{ V}$ ; see Figure 31  |
| Break-Before-Make Time Delay, $t_{BBM}$                  | 74          |                |                 | ns typ            | $R_L = 300\ \Omega$ , $C_L = 35\text{ pF}$  |
|  |             |                | 15              | ns min            | $V_{S1} = V_{S2} = 1.5\text{ V}$ ; see Figure 30  |
| Charge Injection   | 6           |                |                 | pC typ            | $V_S = 1.5\text{ V}$ , $R_S = 0\ \Omega$ , $C_L = 1\text{ nF}$ ; see Figure 32  |
| Off Isolation  | -62         |                |                 | dB typ            | $R_L = 50\ \Omega$ , $C_L = 5\text{ pF}$ , $f = 1\text{ MHz}$ ; see Figure 33   |
| Channel-to-Channel Crosstalk                             | -62         |                |                 | dB typ            | $R_L = 50\ \Omega$ , $C_L = 5\text{ pF}$ , $f = 1\text{ MHz}$ ; see Figure 35   |
| Total Harmonic Distortion + Noise (THD + N)              | 0.6         |                |                 | % typ             | $R_L = 110\ \Omega$ , $f = 20\text{ Hz to }20\text{ kHz}$ , $V_S = 2\text{ V p-p}$ ; see Figure 36                      |
| -3 dB Bandwidth  |             |                |                 |                   | $R_L = 50\ \Omega$ , $C_L = 5\text{ pF}$ ; see Figure 34  |
| ADG1606  | 17          |                |                 | MHz typ           |   |
| ADG1607  | 31          |                |                 | MHz typ           |   |
| $C_S$ (Off)  | 22          |                |                 | pF typ            | $V_S = 1.5\text{ V}$ , $f = 1\text{ MHz}$   |
| $C_D$ (Off)  |             |                |                 |                   |   |
| ADG1606  | 290         |                |                 | pF typ            | $V_S = 1.5\text{ V}$ , $f = 1\text{ MHz}$   |
| ADG1607  | 145         |                |                 | pF typ            | $V_S = 1.5\text{ V}$ , $f = 1\text{ MHz}$   |
| $C_D$ , $C_S$ (On)                                       |             |                |                 |                   |   |
| ADG1606  | 350         |                |                 | pF typ            | $V_S = 1.5\text{ V}$ , $f = 1\text{ MHz}$   |
| ADG1607  | 168         |                |                 | pF typ            | $V_S = 1.5\text{ V}$ , $f = 1\text{ MHz}$   |
| <b>POWER REQUIREMENTS</b>                                |             |                |                 |                   |   |
| $I_{DD}$   | 0.001       |                |                 | $\mu\text{A}$ typ | $V_{DD} = 3.6\text{ V}$   |
|  |             |                | 1.0             | $\mu\text{A}$ max | Digital inputs = 0 V or $V_{DD}$  |
| $V_{DD}$   |             |                | 3.3/16          | V min/max         |   |

<sup>1</sup> Guaranteed by design, not subject to production test.

## ADG1606/ADG1607

### CONTINUOUS CURRENT PER CHANNEL, S OR D

Table 5. ADG1606

| Parameter                                      | 25°C | 85°C | 125°C | Unit       |
|--|------|------|-------|------------|
| CONTINUOUS CURRENT, S OR D                     |      |      |       |            |
| $V_{DD} = +5\text{ V}, V_{SS} = -5\text{ V}$   |      |      |       |            |
| TSSOP ( $\theta_{JA} = 97.9^\circ\text{C/W}$ ) | 259  | 168  | 105   | mA maximum |
| LFCSP ( $\theta_{JA} = 46^\circ\text{C/W}$ )   | 357  | 217  | 122   | mA maximum |
| $V_{DD} = 12\text{ V}, V_{SS} = 0\text{ V}$    |      |      |       |            |
| TSSOP ( $\theta_{JA} = 97.9^\circ\text{C/W}$ ) | 273  | 175  | 108   | mA maximum |
| LFCSP ( $\theta_{JA} = 46^\circ\text{C/W}$ )   | 378  | 224  | 122   | mA maximum |
| $V_{DD} = 5\text{ V}, V_{SS} = 0\text{ V}$     |      |      |       |            |
| TSSOP ( $\theta_{JA} = 97.9^\circ\text{C/W}$ ) | 199  | 136  | 91    | mA maximum |
| LFCSP ( $\theta_{JA} = 46^\circ\text{C/W}$ )   | 276  | 178  | 108   | mA maximum |
| $V_{DD} = 3.3\text{ V}, V_{SS} = 0\text{ V}$   |      |      |       |            |
| TSSOP ( $\theta_{JA} = 97.9^\circ\text{C/W}$ ) | 164  | 119  | 80    | mA maximum |
| LFCSP ( $\theta_{JA} = 46^\circ\text{C/W}$ )   | 227  | 154  | 98    | mA maximum |

Table 6. ADG1607

| Parameter                                      | 25°C | 85°C | 125°C | Unit       |
|--|------|------|-------|------------|
| CONTINUOUS CURRENT, S OR D                     |      |      |       |            |
| $V_{DD} = +5\text{ V}, V_{SS} = -5\text{ V}$   |      |      |       |            |
| TSSOP ( $\theta_{JA} = 97.9^\circ\text{C/W}$ ) | 192  | 133  | 91    | mA maximum |
| LFCSP ( $\theta_{JA} = 46^\circ\text{C/W}$ )   | 266  | 175  | 108   | mA maximum |
| $V_{DD} = 12\text{ V}, V_{SS} = 0\text{ V}$    |      |      |       |            |
| TSSOP ( $\theta_{JA} = 97.9^\circ\text{C/W}$ ) | 203  | 140  | 91    | mA maximum |
| LFCSP ( $\theta_{JA} = 46^\circ\text{C/W}$ )   | 280  | 178  | 108   | mA maximum |
| $V_{DD} = 5\text{ V}, V_{SS} = 0\text{ V}$     |      |      |       |            |
| TSSOP ( $\theta_{JA} = 97.9^\circ\text{C/W}$ ) | 147  | 108  | 70    | mA maximum |
| LFCSP ( $\theta_{JA} = 46^\circ\text{C/W}$ )   | 206  | 140  | 94    | mA maximum |
| $V_{DD} = 3.3\text{ V}, V_{SS} = 0\text{ V}$   |      |      |       |            |
| TSSOP ( $\theta_{JA} = 97.9^\circ\text{C/W}$ ) | 122  | 91   | 56    | mA maximum |
| LFCSP ( $\theta_{JA} = 46^\circ\text{C/W}$ )   | 168  | 119  | 84    | mA maximum |



## ADG1606/ADG1607

### ABSOLUTE MAXIMUM RATINGS

$T_A = 25^\circ\text{C}$ , unless otherwise noted.

Table 7.

| Parameter   | Rating  |
|---|---|
| $V_{DD}$ to $V_{SS}$                                  | 18 V  |
| $V_{DD}$ to GND                                       | -0.3 V to +18 V   |
| $V_{SS}$ to GND                                       | +0.3 V to -18 V   |
| Analog Inputs <sup>1</sup>                            | $V_{SS} - 0.3\text{ V}$ to $V_{DD} + 0.3\text{ V}$ or 30 mA, whichever occurs first |
| Digital Inputs <sup>2</sup>                           | GND - 0.3 V to $V_{DD} + 0.3\text{ V}$ or 30 mA, whichever occurs first             |
| Peak Current, S or D                                  | 1.1 A (pulsed at 1 ms, 10% duty cycle maximum)                                      |
| Continuous Current, S or D <sup>3</sup>               | Data + 15%  |
| Operating Temperature Range<br>Industrial (B Version) | -40°C to +125°C   |
| Storage Temperature Range                             | -65°C to +150°C   |
| Junction Temperature                                  | 150°C   |
| Reflow Soldering Peak Temperature, Pb Free            | 260°C   |

<sup>1</sup> Overvoltages at IN, S, or D are clamped by internal diodes. Current should be limited to the maximum ratings given.

<sup>2</sup> Overvoltages at the Ax, EN, Sx, or Dx pins are clamped by internal diodes. Current should be limited to the maximum ratings given.

<sup>3</sup> See Table 5.

Stresses above those listed under Absolute Maximum Ratings may cause permanent damage to the device. This is a stress rating only; functional operation of the device at these or any other conditions above those indicated in the operational section of this specification is not implied. Exposure to absolute maximum rating conditions for extended periods may affect device reliability.

Only one absolute maximum rating may be applied at any one time.

### THERMAL RESISTANCE

$\theta_{JA}$  is specified for the worst-case conditions, that is, a device soldered in a circuit board for surface-mount packages.

Table 8. Thermal Resistance

| Package Type     | $\theta_{JA}$ | $\theta_{JC}$ | Unit |
|------------------|---------------|---------------|------|
| 28-Lead TSSOP    | 97.9          | 14            | °C/W |
| 32-Lead LFCSP_VQ | 46            |               | °C/W |

### ESD CAUTION



**ESD (electrostatic discharge) sensitive device.** Charged devices and circuit boards can discharge without detection. Although this product features patented or proprietary protection circuitry, damage may occur on devices subjected to high energy ESD. Therefore, proper ESD precautions should be taken to avoid performance degradation or loss of functionality.

# ADG1606/ADG1607

## PIN CONFIGURATIONS AND FUNCTION DESCRIPTIONS

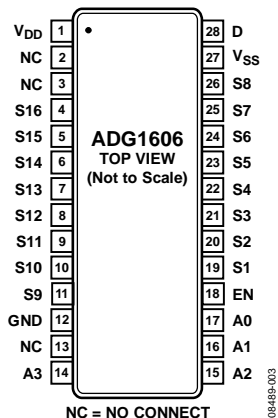
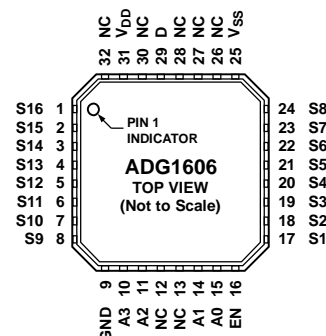

Figure 3. ADG1606 TSSOP Pin Configuration



NOTES  
 1. NC = NO CONNECT.  
 2. EXPOSED PAD TIED TO SUBSTRATE, V<sub>SS</sub>.

Figure 4. ADG1606 LFCSP\_VQ Pin Configuration

Table 9. ADG1606 Pin Function Descriptions

| Pin No.  |                            | Mnemonic        | Description  |
|----------|----------------------------|-----------------|--|
| TSSOP    | LFCSP_VQ                   |                 |  |
| 1        | 31                         | V <sub>DD</sub> | Most Positive Power Supply Potential.  |
| 2, 3, 13 | 12, 13, 26, 27, 28, 30, 32 | NC              | No Connect.  |
| 4        | 1                          | S16             | Source Terminal 16. This pin can be an input or an output.   |
| 5        | 2                          | S15             | Source Terminal 15. This pin can be an input or an output.   |
| 6        | 3                          | S14             | Source Terminal 14. This pin can be an input or an output.   |
| 7        | 4                          | S13             | Source Terminal 13. This pin can be an input or an output.   |
| 8        | 5                          | S12             | Source Terminal 12. This pin can be an input or an output.   |
| 9        | 6                          | S11             | Source Terminal 11. This pin can be an input or an output.   |
| 10       | 7                          | S10             | Source Terminal 10. This pin can be an input or an output.   |
| 11       | 8                          | S9              | Source Terminal 9. This pin can be an input or an output.  |
| 12       | 9                          | GND             | Ground (0 V) Reference.  |
| 14       | 10                         | A3              | Logic Control Input.   |
| 15       | 11                         | A2              | Logic Control Input.   |
| 16       | 14                         | A1              | Logic Control Input.   |
| 17       | 15                         | A0              | Logic Control Input.   |
| 18       | 16                         | EN              | Active High Digital Input. When this pin is low, the device is disabled and all switches are turned off. When this pin is high, the Ax logic inputs determine which switch is turned on.               |
| 19       | 17                         | S1              | Source Terminal 1. This pin can be an input or an output.  |
| 20       | 18                         | S2              | Source Terminal 2. This pin can be an input or an output.  |
| 21       | 19                         | S3              | Source Terminal 3. This pin can be an input or an output.  |
| 22       | 20                         | S4              | Source Terminal 4. This pin can be an input or an output.  |
| 23       | 21                         | S5              | Source Terminal 5. This pin can be an input or an output.  |
| 24       | 22                         | S6              | Source Terminal 6. This pin can be an input or an output.  |
| 25       | 23                         | S7              | Source Terminal 7. This pin can be an input or an output.  |
| 26       | 24                         | S8              | Source Terminal 8. This pin can be an input or an output.  |
| 27       | 25                         | V <sub>SS</sub> | Most Negative Power Supply Potential. In single-supply applications, this pin can be connected to ground.  |
| 28       | 29                         | D               | Drain Terminal. This pin can be an input or an output.   |
|          | EPAD                       | Exposed Pad     | The exposed pad is connected internally. For increased reliability of the solder joints and maximum thermal capability, it is recommended that the pad be soldered to the substrate, V <sub>SS</sub> . |

## ADG1606/ADG1607

Table 10. ADG1606 Truth Table

| A3             | A2             | A1             | A0             | EN | On Switch |
|----------------|----------------|----------------|----------------|----|-----------|
| X <sup>1</sup> | X <sup>1</sup> | X <sup>1</sup> | X <sup>1</sup> | 0  | None      |
| 0              | 0              | 0              | 0              | 1  | 1         |
| 0              | 0              | 0              | 1              | 1  | 2         |
| 0              | 0              | 1              | 0              | 1  | 3         |
| 0              | 0              | 1              | 1              | 1  | 4         |
| 0              | 1              | 0              | 0              | 1  | 5         |
| 0              | 1              | 0              | 1              | 1  | 6         |
| 0              | 1              | 1              | 0              | 1  | 7         |
| 0              | 1              | 1              | 1              | 1  | 8         |
| 1              | 0              | 0              | 0              | 1  | 9         |
| 1              | 0              | 0              | 1              | 1  | 10        |
| 1              | 0              | 1              | 0              | 1  | 11        |
| 1              | 0              | 1              | 1              | 1  | 12        |
| 1              | 1              | 0              | 0              | 1  | 13        |
| 1              | 1              | 0              | 1              | 1  | 14        |
| 1              | 1              | 1              | 0              | 1  | 15        |
| 1              | 1              | 1              | 1              | 1  | 16        |

<sup>1</sup>X = don't care.

# ADG1606/ADG1607

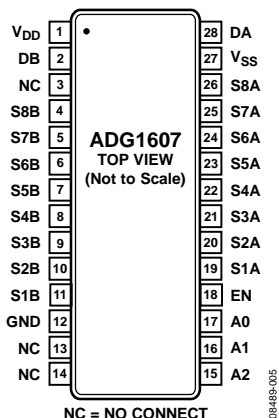

Figure 5. ADG1607 TSSOP Pin Configuration

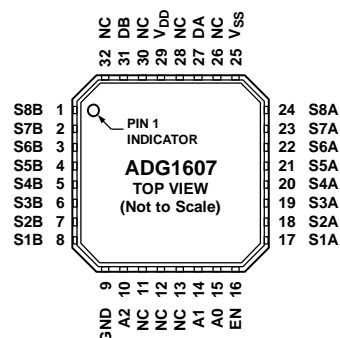

Figure 6. ADG1607 LFCSP\_VQ Pin Configuration

Table 11. ADG1607 Pin Function Descriptions

| Pin No.   |                            | Mnemonic        | Description  |
|-----------|----------------------------|-----------------|--|
| TSSOP     | LFCSP_VQ                   |                 |  |
| 1         | 29                         | V <sub>DD</sub> | Most Positive Power Supply Potential.  |
| 2         | 31                         | DB              | Drain Terminal B. This pin can be an input or an output.   |
| 3, 13, 14 | 11, 12, 13, 26, 28, 30, 32 | NC              | No Connect.  |
| 4         | 1                          | S8B             | Source Terminal 8B. This pin can be an input or an output.   |
| 5         | 2                          | S7B             | Source Terminal 7B. This pin can be an input or an output.   |
| 6         | 3                          | S6B             | Source Terminal 6B. This pin can be an input or an output.   |
| 7         | 4                          | S5B             | Source Terminal 5B. This pin can be an input or an output.   |
| 8         | 5                          | S4B             | Source Terminal 4B. This pin can be an input or an output.   |
| 9         | 6                          | S3B             | Source Terminal 3B. This pin can be an input or an output.   |
| 10        | 7                          | S2B             | Source Terminal 2B. This pin can be an input or an output.   |
| 11        | 8                          | S1B             | Source Terminal 1B. This pin can be an input or an output.   |
| 12        | 9                          | GND             | Ground (0 V) Reference.  |
| 15        | 10                         | A2              | Logic Control Input.   |
| 16        | 14                         | A1              | Logic Control Input.   |
| 17        | 15                         | A0              | Logic Control Input.   |
| 18        | 16                         | EN              | Active High Digital Input. When this pin is low, the device is disabled and all switches are turned off. When this pin is high, the Ax logic inputs determine which switch is turned on.               |
| 19        | 17                         | S1A             | Source Terminal 1A. This pin can be an input or an output.   |
| 20        | 18                         | S2A             | Source Terminal 2A. This pin can be an input or an output.   |
| 21        | 19                         | S3A             | Source Terminal 3A. This pin can be an input or an output.   |
| 22        | 20                         | S4A             | Source Terminal 4A. This pin can be an input or an output.   |
| 23        | 21                         | S5A             | Source Terminal 5A. This pin can be an input or an output.   |
| 24        | 22                         | S6A             | Source Terminal 6A. This pin can be an input or an output.   |
| 25        | 23                         | S7A             | Source Terminal 7A. This pin can be an input or an output.   |
| 26        | 24                         | S8A             | Source Terminal 8A. This pin can be an input or an output.   |
| 27        | 25                         | V <sub>SS</sub> | Most Negative Power Supply Potential. In single-supply applications, this pin can be connected to ground.  |
| 28        | 27                         | DA              | Drain Terminal A. This pin can be an input or an output.   |
|           | EPAD                       | Exposed Pad     | The exposed pad is connected internally. For increased reliability of the solder joints and maximum thermal capability, it is recommended that the pad be soldered to the substrate, V <sub>SS</sub> . |

## ADG1606/ADG1607

Table 12. ADG1607 Truth Table

| A2             | A1             | A0             | EN | On Switch Pair |
|----------------|----------------|----------------|----|----------------|
| X <sup>1</sup> | X <sup>1</sup> | X <sup>1</sup> | 0  | None           |
| 0              | 0              | 0              | 1  | 1              |
| 0              | 0              | 1              | 1  | 2              |
| 0              | 1              | 0              | 1  | 3              |
| 0              | 1              | 1              | 1  | 4              |
| 1              | 0              | 0              | 1  | 5              |
| 1              | 0              | 1              | 1  | 6              |
| 1              | 1              | 0              | 1  | 7              |
| 1              | 1              | 1              | 1  | 8              |

<sup>1</sup>X = don't care.

**TYPICAL PERFORMANCE CHARACTERISTICS**

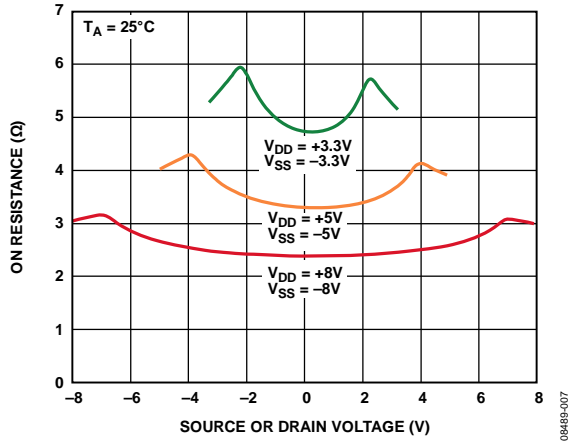

Figure 7. On Resistance as a Function of  $V_D$  ( $V_S$ ) for Dual Supply

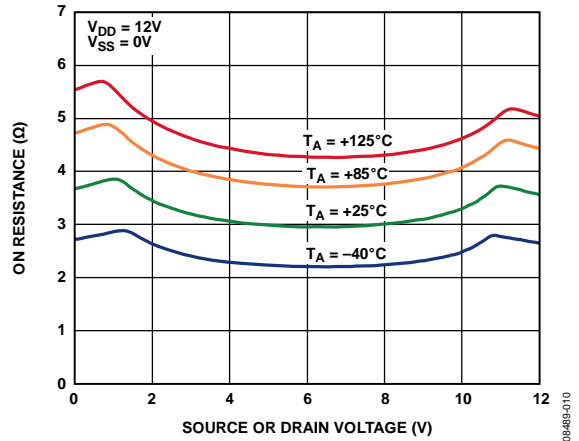

Figure 10. On Resistance as a Function of  $V_D$  ( $V_S$ ) for Different Temperatures, 12 V Single Supply

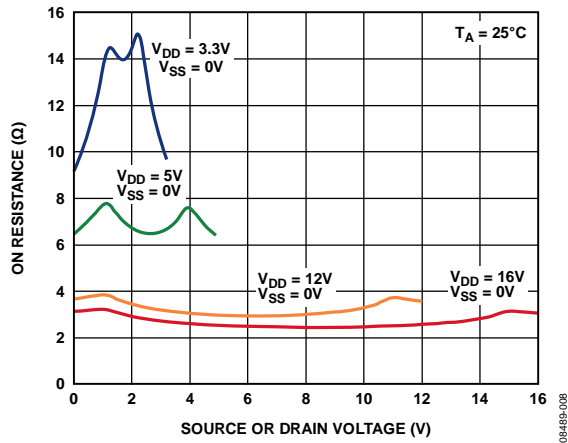

Figure 8. On Resistance as a Function of  $V_D$  ( $V_S$ ) for Single Supply

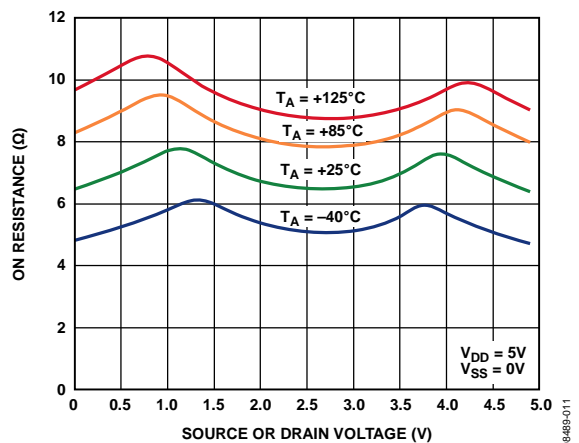

Figure 11. On Resistance as a Function of  $V_D$  ( $V_S$ ) for Different Temperatures, 5 V Single Supply

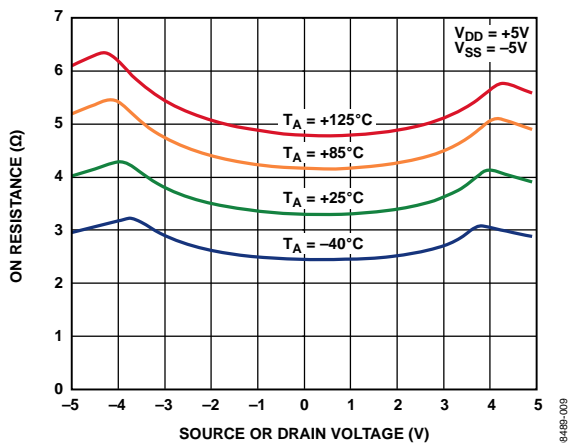

Figure 9. On Resistance as a Function of  $V_D$  ( $V_S$ ) for Different Temperatures,  $\pm 5$  V Dual Supply

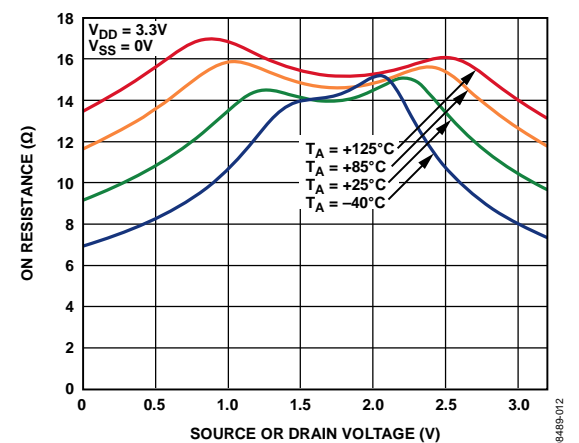

Figure 12. On Resistance as a Function of  $V_D$  ( $V_S$ ) for Different Temperatures, 3.3 V Single Supply

**ADG1606/ADG1607**

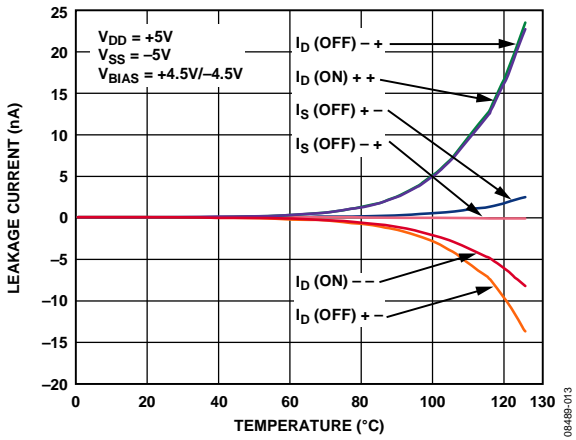

Figure 13. Leakage Currents as a Function of Temperature, ±5 V Dual Supply

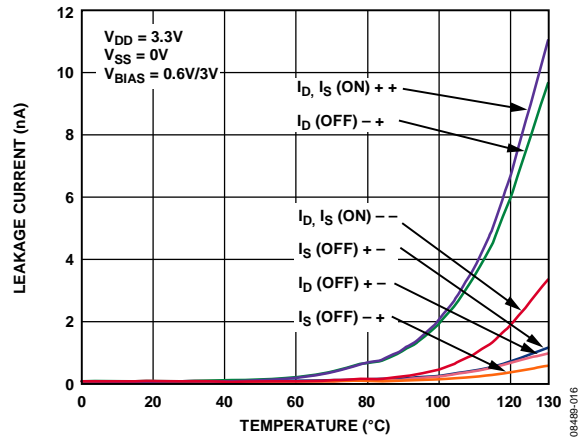

Figure 16. Leakage Currents as a Function of Temperature, 3.3 V Single Supply

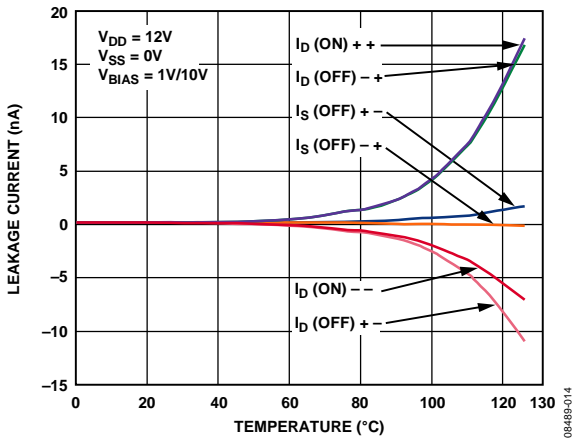

Figure 14. Leakage Currents as a Function of Temperature, 12 V Single Supply

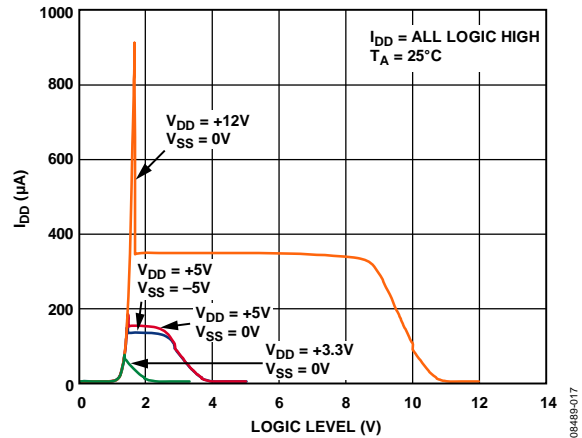

Figure 17.  $I_{DD}$  vs. Logic Level

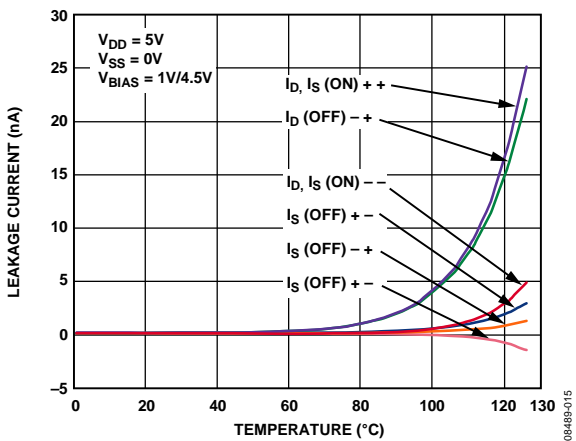

Figure 15. Leakage Currents as a Function of Temperature, 5 V Single Supply

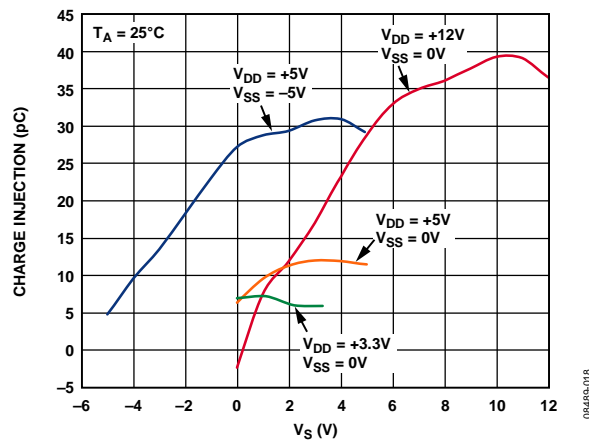

Figure 18. Charge Injection vs. Source Voltage

**ADG1606/ADG1607**

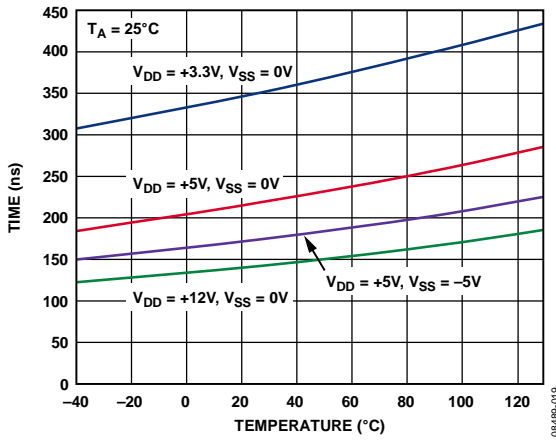

Figure 19. Transition Time vs. Temperature

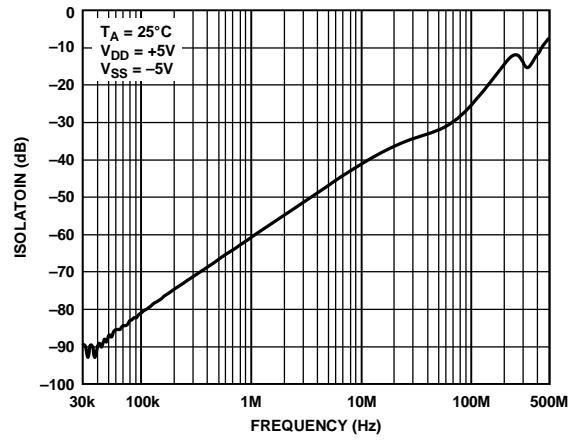

Figure 21. ADG1606 Crosstalk vs. Frequency

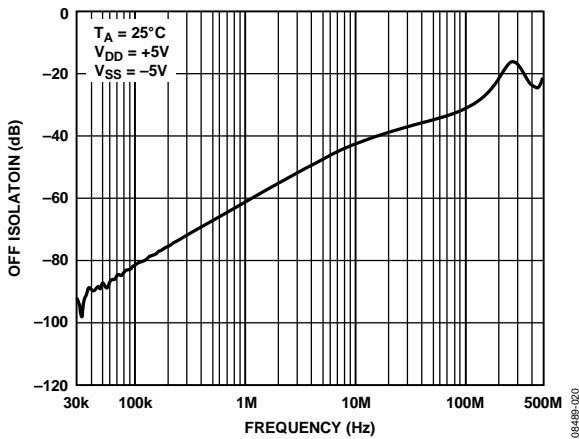

Figure 20. Off Isolation vs. Frequency

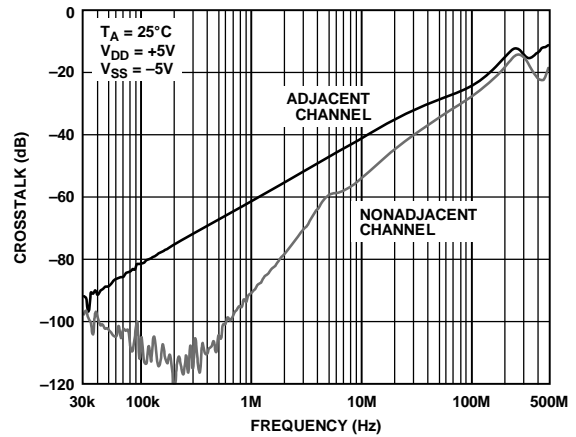

Figure 22. ADG1607 Crosstalk vs. Frequency



**ADG1606/ADG1607**

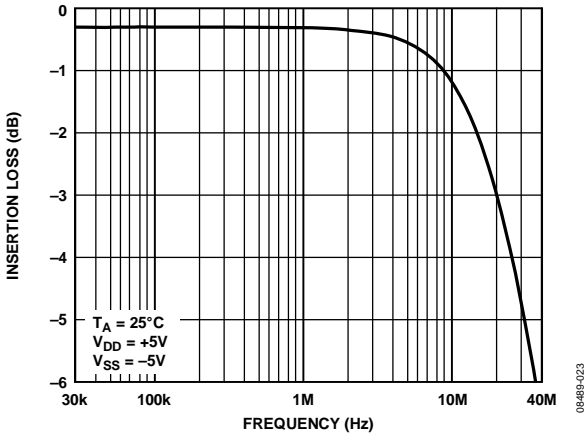

Figure 23. ADG1606 On Response vs. Frequency

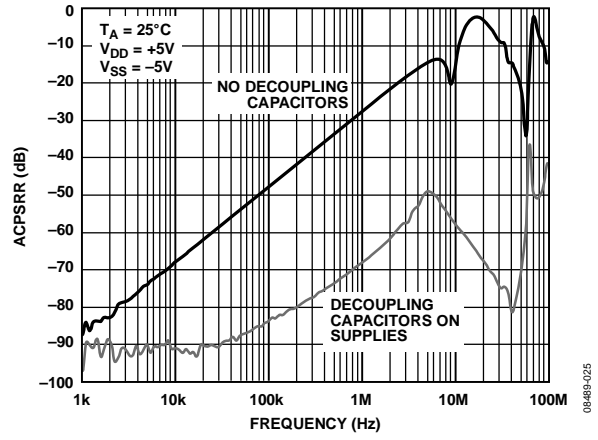

Figure 25. ACPSRR vs. Frequency

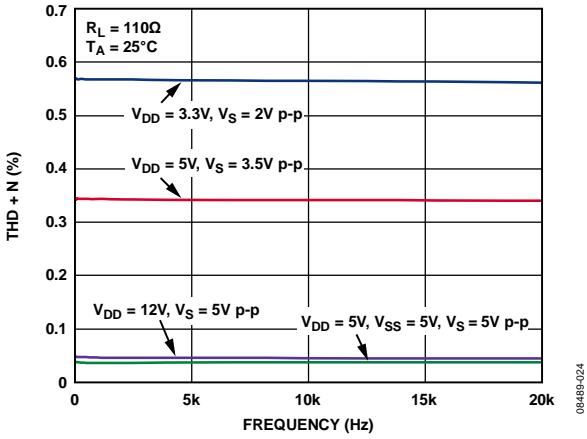

Figure 24. THD + N vs. Frequency

**TEST CIRCUITS**

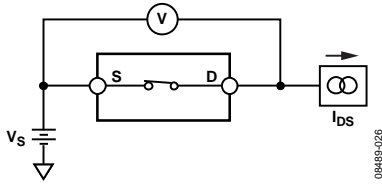

Figure 26. On Resistance

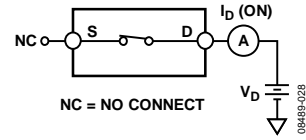

Figure 28. On Leakage

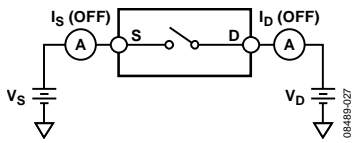

Figure 27. Off Leakage

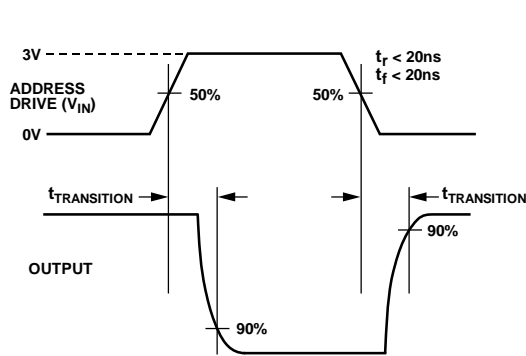

Figure 29. Address to Output Switching Times,  $t_{\text{TRANSITION}}$

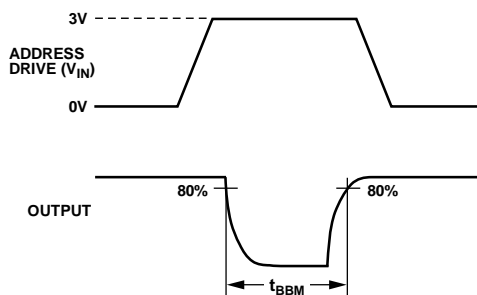
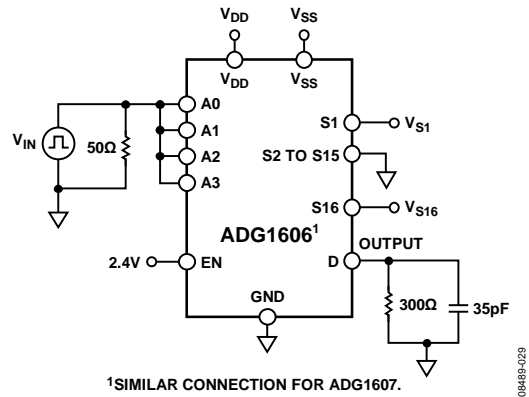
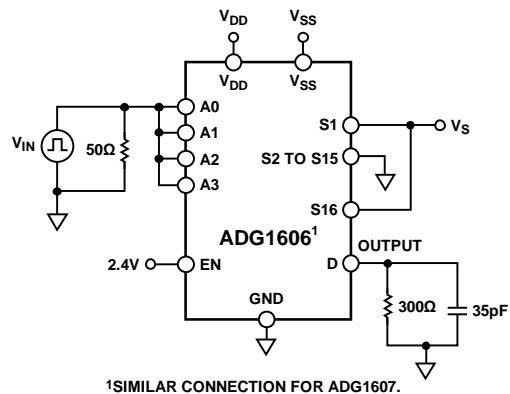

Figure 30. Break-Before-Make Delay,  $t_{\text{BBM}}$



**ADG1606/ADG1607**

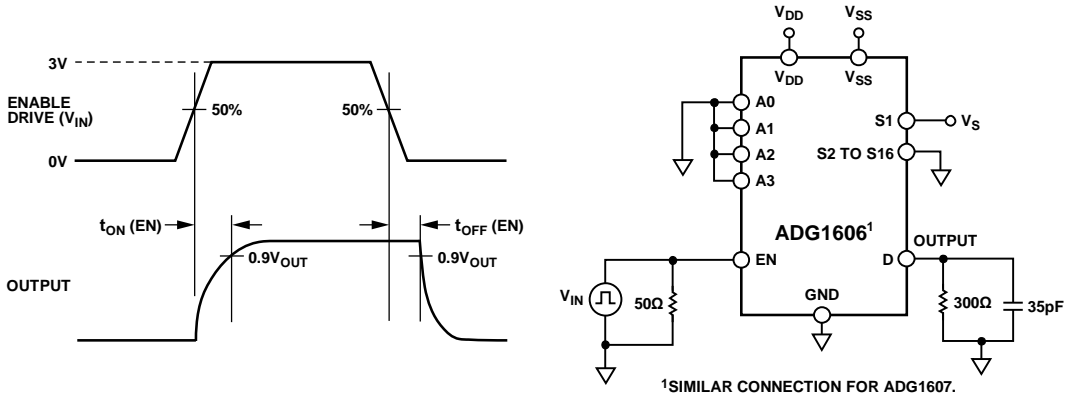

Figure 31. Enable Delay,  $t_{ON}(EN)$ ,  $t_{OFF}(EN)$

06489-031

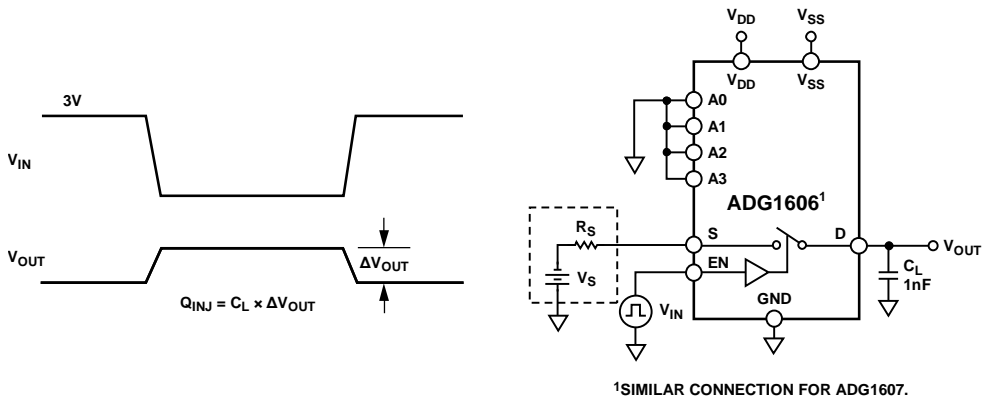

Figure 32. Charge Injection

06489-032

**ADG1606/ADG1607**

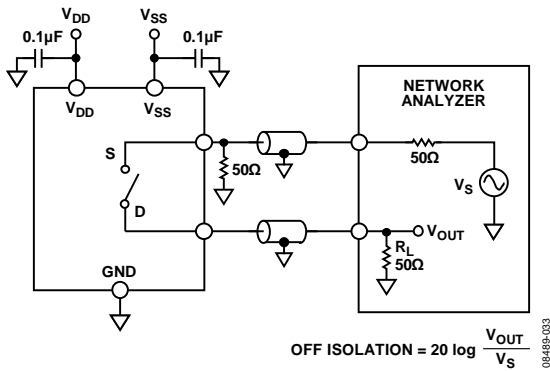

Figure 33. Off Isolation

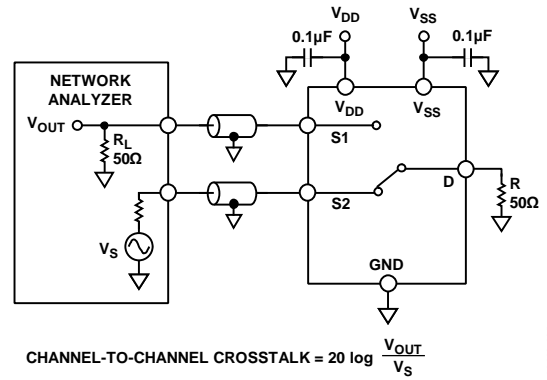

Figure 35. Channel-to-Channel Crosstalk

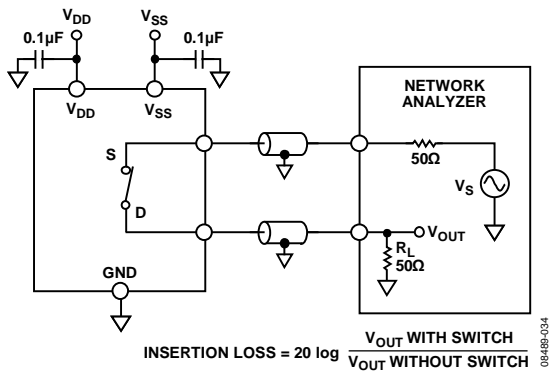

Figure 34. Bandwidth

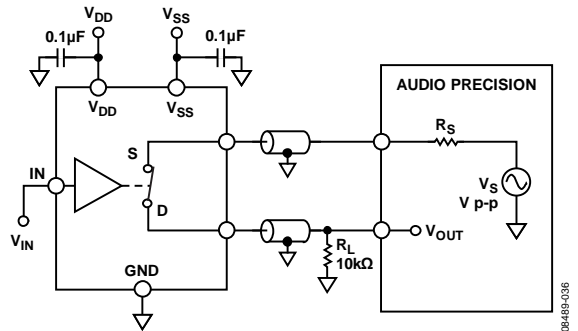

Figure 36. THD + N

## ADG1606/ADG1607

### TERMINOLOGY

#### $R_{ON}$

Ohmic resistance between the D and S terminals.

#### $\Delta R_{ON}$

Difference between the  $R_{ON}$  of any two channels.

#### $R_{FLAT(ON)}$

Flatness is defined as the difference between the maximum and minimum value of on resistance as measured.

#### $I_S$ (Off)

Source leakage current when the switch is off.

#### $I_D$ (Off)

Drain leakage current when the switch is off.

#### $I_D, I_S$ (On)

Channel leakage current when the switch is on.

#### $V_D, V_S$

Analog voltage on Terminal D and Terminal S.

#### $C_S$ (Off)

Channel input capacitance for the off condition.

#### $C_D$ (Off)

Channel output capacitance for the off condition.

#### $C_D, C_S$ (On)

On switch capacitance.

#### $C_{IN}$

Digital input capacitance.

#### $t_{ON}$ (EN)

Delay time between the 50% and 90% points of the digital input and the switch on condition.

#### $t_{OFF}$ (EN)

Delay time between the 50% and 90% points of the digital input and the switch off condition.

#### $t_{TRANSITION}$

Delay time between the 50% and 90% points of the digital inputs and the switch on condition when switching from one address state to another.

#### $t_{BBM}$

Off time measured between the 80% points of the switches when switching from one address state to another.

#### $V_{INL}$

Maximum input voltage for Logic 0.

#### $V_{INH}$

Minimum input voltage for Logic 1.

#### $I_{INL}, I_{INH}$

Input current of the digital input.

#### $I_{DD}$

Positive supply current.

#### $I_{SS}$

Negative supply current.

#### Off Isolation

A measure of unwanted signal coupling through an off channel.

#### Charge Injection

A measure of the glitch impulse transferred from the digital input to the analog output during switching.

#### Bandwidth

The frequency at which the output is attenuated by 3 dB.

#### On Response

The frequency response of the on switch.

#### THD + N

The ratio of the harmonic amplitude plus noise of the signal to the fundamental.

#### AC Power Supply Rejection Ratio (ACPSRR)

Measures the ability of a part to avoid coupling noise and spurious signals that appear on the supply voltage pin to the output of the switch. The dc voltage on the device is modulated by a sine wave of 0.62 V p-p. The ratio of the amplitude of signal on the output to the amplitude of the modulation is the ACPSRR.

**OUTLINE DIMENSIONS**

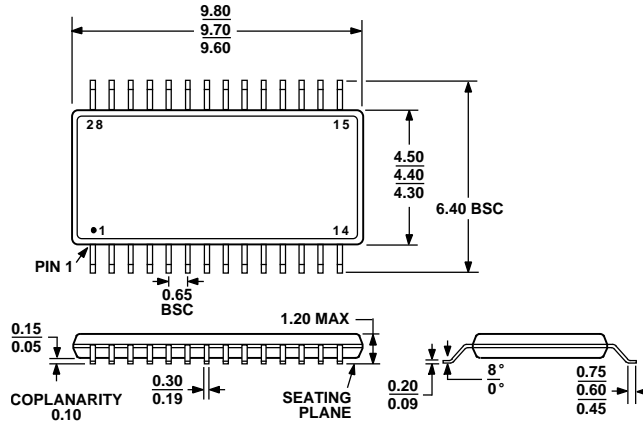

COMPLIANT TO JEDEC STANDARDS MO-153-AE  
 Figure 37. 28-Lead Thin Shrink Small Outline Package [TSSOP]  
 (RU-28)  
 Dimensions shown in millimeters

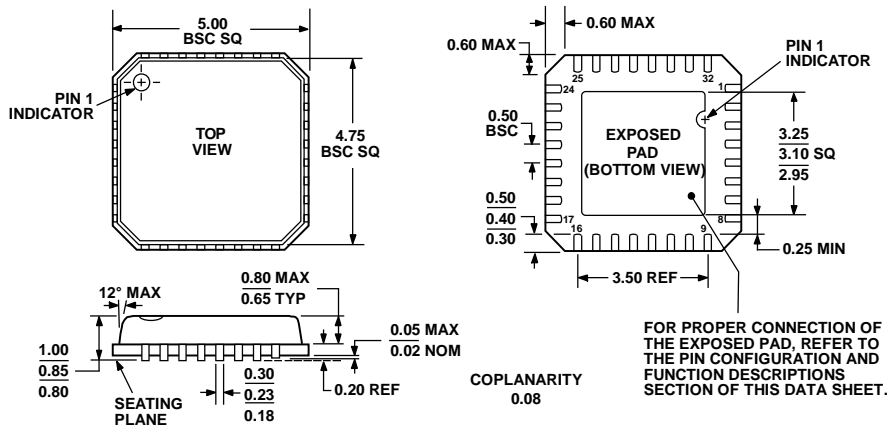

COMPLIANT TO JEDEC STANDARDS MO-220-VHHD-2  
 Figure 38. 32-Lead Lead Frame Chip Scale Package [LFCSP\_VQ]  
 5 mm × 5 mm Body, Very Thin Quad  
 (CP-32-2)  
 Dimensions shown in millimeters

**ORDERING GUIDE**

| Model                          | Temperature Range | Package Description                               | Package Option |
|--------------------------------|-------------------|---|----------------|
| ADG1606BRUZ <sup>1</sup>       | -40°C to +125°C   | 28-Lead Thin Shrink Small Outline Package [TSSOP] | RU-28          |
| ADG1606BRUZ-REEL7 <sup>1</sup> | -40°C to +125°C   | 28-Lead Thin Shrink Small Outline Package [TSSOP] | RU-28          |
| ADG1606BCPZ-REEL7 <sup>1</sup> | -40°C to +125°C   | 32-Lead Lead Frame Chip Scale Package [LFCSP_VQ]  | CP-32-2        |
| ADG1607BRUZ <sup>1</sup>       | -40°C to +125°C   | 28-Lead Thin Shrink Small Outline Package [TSSOP] | RU-28          |
| ADG1607BRUZ-REEL7 <sup>1</sup> | -40°C to +125°C   | 28-Lead Thin Shrink Small Outline Package [TSSOP] | RU-28          |
| ADG1607BCPZ-REEL7 <sup>1</sup> | -40°C to +125°C   | 32-Lead Lead Frame Chip Scale Package [LFCSP_VQ]  | CP-32-2        |

<sup>1</sup> Z = RoHS Compliant Part.

**ADG1606/ADG1607**

**NOTES**

**ADG1606/ADG1607**

## NOTES



**ADG1606/ADG1607**

**NOTES**