

Excellent Integrated System Limited

Stocking Distributor

Click to view price, real time Inventory, Delivery & Lifecycle Information:

[STMicroelectronics](#)
[L5957](#)

For any questions, you can email us directly:

sales@integrated-circuit.com



L5957

Multifunction voltage regulator for car radio

Features

- Four outputs:
 - 8.5 V @ 500 mA
 - 5 V @ 300 mA Permanent
 - 5 V @ 800 mA
 - 3.3 V @ 800 mA
- 2 A high side driver
- Reset function
- Ignition comparator
- Load dump protection
- Thermal shutdown
- Overcurrent limitation
- All pins ESD protected

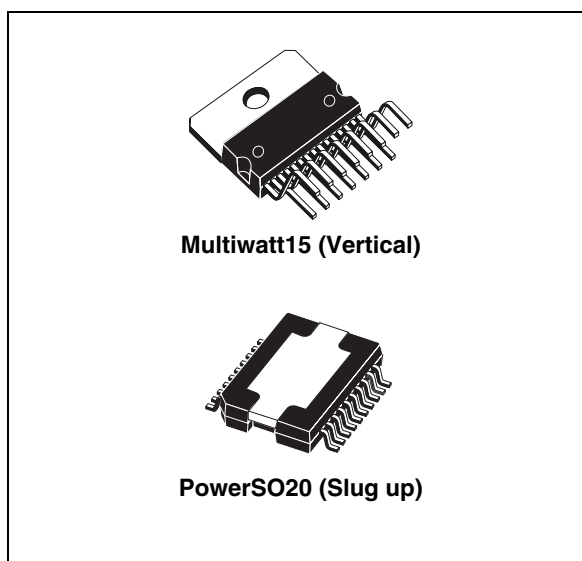

Description

The L5957 contains a triple voltage regulator and a power switch.

The IC includes a monitoring circuit for detection.

The IC features a very low quiescent current in standby.

Table 1. Device summary

Order code	Package	Packing
L5957PD	PowerSO20 (slug up)	Tube
L5957PDTR	PowerSO20 (slug up)	Tape and reel
L5957	Multiwatt15 (Vertical)	Tube

Contents

1	Block and pins connection diagrams	5
2	Electrical specifications	6
2.1	Absolute maximum ratings	6
2.2	Thermal data	6
2.3	Electrical characteristics	6
3	Package information	13
4	Revision history	15

List of tables

Table 1.	Device summary	1
Table 2.	Absolute maximum ratings	6
Table 3.	Thermal data	6
Table 4.	Electrical characteristics	6
Table 5.	Document revision history	15

List of figures

Figure 1.	Block diagram	5
Figure 2.	Pins connection	5
Figure 3.	Typical application circuit	9
Figure 4.	Maximum ESR for stability valid for all the regulators outputs	10
Figure 5.	Timing diagram of regulators and power switch	10
Figure 6.	Backup and reset diagram	11
Figure 7.	Hold and thermal protection	11
Figure 8.	Ignition buffer diagram	12
Figure 9.	Protection of the power switch	12
Figure 10.	Short circuit diagram	12
Figure 11.	PowerSO20 (slug up) mechanical data and package dimensions	13
Figure 12.	Multiwatt15 (vertical) mechanical data and package dimensions	14

L5957

Block and pins connection diagrams

1 Block and pins connection diagrams

Figure 1. Block diagram

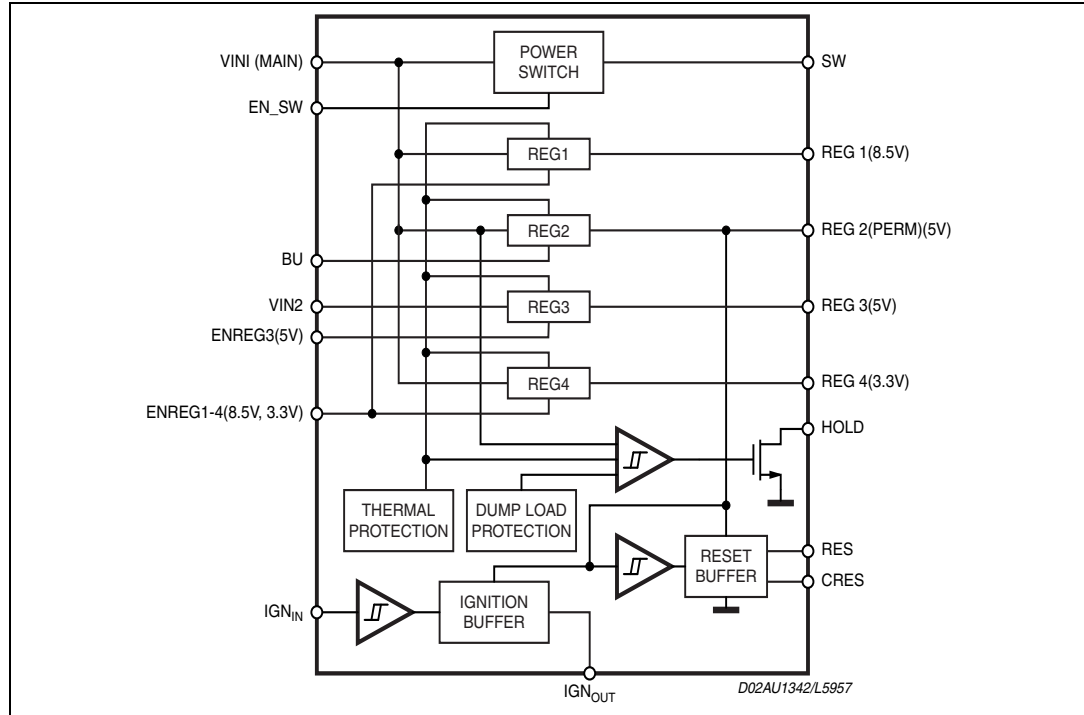
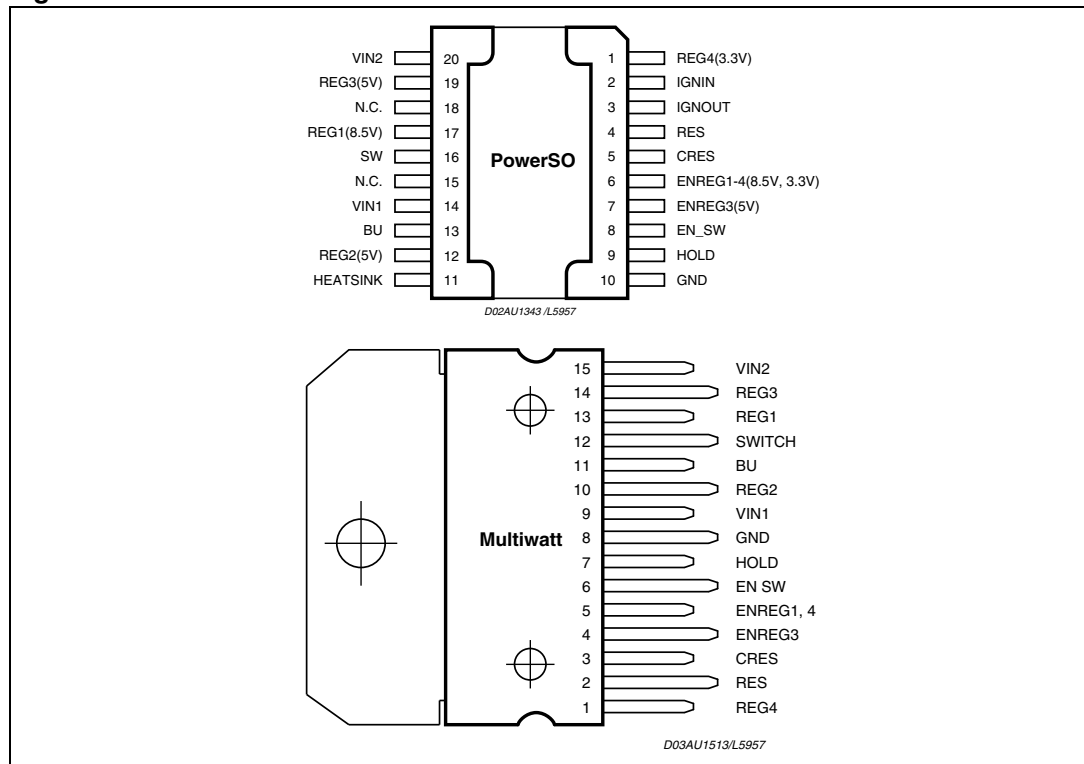

Figure 2. Pins connection



Electrical specifications

L5957

2 Electrical specifications

2.1 Absolute maximum ratings

Table 2. Absolute maximum ratings

Symbol	Parameter	Value	Unit
V _{SDC}	DC operating supply voltage	30	V
V _{STR}	Transient supply voltage	50	V
I _O	Output current	internally limited	
T _{op}	Operating temperature range	-40 to 85	°C
T _{stg}	Storage temperature	-55 to 150	°C
T _j	Junction temperature	-55 to 150	°C
P _d	Power dissipation T _{case} = 85 °C	43	W

2.2 Thermal data

Table 3. Thermal data

Symbol	Parameter	PowerSO	Multiwatt	Unit
R _{th j-case}	Thermal resistance junction-to-case	Max. 1.5	1.8	°C/W

2.3 Electrical characteristics

V_S = 14.4 V; T_{amb} = 25 °C; unless otherwise specified.

Table 4. Electrical characteristics

Symbol	Parameter	Test condition	Min.	Typ.	Max.	Unit
Input supplies						
V _{in1}	Input supply voltage 1	Operating	9	-	18	V
V _{in2}	Input supply voltage 2	Operating	6	-	18	V
I _q	Total quiescent current	Standby (-20 °C to 85 °C) IGN _{IN} = 5 V	-	-	70	µA
		REGx = 5 V, REGsw = 5 V, IGN _{IN} = 5 V	-	5	-	mA
		Standby (-20 °C to 85 °C) IGN _{IN} = 5 V, V _{CC} = 18 V	-	100	-	µA
Load Dump V _{in1}	Battery over voltage	V _{in1}	18	20	22	V
Load Dump V _{in2}		V _{in2}	18	20	22	V

L5957

Electrical specifications

Table 4. Electrical characteristics (continued)

Symbol	Parameter	Test condition	Min.	Typ.	Max.	Unit
Regulator 1						
V_o (REG 1)	Output voltage 8.5 V	-	8	8.5	9	V
ΔV	Line regulation	$V_{in1} = 10$ to 18 V; $I = 500$ mA	-	-	50	mV
		$V_{in1} = 9.3$ to 18 V; $I = 10$ mA	-	-	50	mV
ΔV_i	Load regulation	$I_{reg1} = 1$ to 500 mA	-	-	100	mV
I_q	Quiescent current	$I_{reg1} = 10$ mA	-	-	5	mA
PSRR	Supply voltage ripple rejection	$f = 1$ kHz; $V_{in1} = 1.5$ Vpp; $I_o = 500$ mA	50	-	-	dB
V_{drop}	Drop out voltage	$I_{reg1} = 500$ mA ⁽¹⁾	-	-	0.6	V
I_m	Current limit	$R_{short} = 0.5 \Omega$	0.6	-	1.2	A
Regulator 2						
V_o (ST BY)	Output voltage 5 V	-	4.7	5	5.3	V
ΔV	Line regulation	$V_{in1} = 7$ to 18 V; $I = 300$ mA	-	-	50	mV
		$V_{in1} = 6$ to 18 V; $I = 10$ mA	-	-	50	mV
ΔV_i	Load regulation	$I_{reg2} = 1$ to 300 mA	-	-	100	mV
I_q	Quiescent Current	$I_{reg2} = 10$ mA	-	-	3	mA
PSRR	Supply voltage ripple rejection	$f = 1$ kHz; $V_{in1} = 1.5$ Vpp; $I_o = 300$ mA	50	-	-	dB
V_{drop}	Drop out voltage	$I_{reg2} = 300$ mA ⁽¹⁾	-	-	1.5	V
		$I_{reg2} = 100$ mA ⁽¹⁾	-	-	0.6	V
I_m	Current limit	$R_{short} = 0.5 \Omega$	400	-	800	mA
Regulator 3						
V_o (REG 3)	Output voltage 5V	-	4.75	5	5.25	V
ΔV	Line regulation	$V_{in2} = 7$ to 18 V; $I = 800$ mA	-	-	50	mV
		$V_{in2} = 6$ to 18 V; $I = 10$ mA	-	-	50	mV
ΔV_i	Load regulation	$I_{reg3} = 1$ to 800 mA	-	-	100	mV
I_q	Quiescent current	$I_{reg3} = 10$ mA	-	-	5	mA
PSRR	Supply voltage ripple rejection	$f = 1$ kHz; $V_{in1} = 1.5$ Vpp; $I_o = 800$ mA	50	-	-	dB
V_{drop}	Drop out voltage	$I_{reg3} = 800$ mA ⁽¹⁾	-	-	1.5	V
I_m	Current limit	$R_{short} = 0.5 \Omega$	1	-	2	A
Regulator 4						
V_o (REG 4)	Output voltage 3.3V	-	3.10	3.3	3.50	V
ΔV	Line regulation	$V_{in2} = 6$ to 18 V; $I = 800$ mA	-	-	50	mV
ΔV	Line regulation	$V_{in2} = 6$ to 18 V; $I = 10$ mA	-	-	50	mV

Electrical specifications

L5957

Table 4. Electrical characteristics (continued)

Symbol	Parameter	Test condition	Min.	Typ.	Max.	Unit
ΔV_i	Load regulation	$I_{reg4} = 1$ to 800 mA	-	-	100	mV
I_q	Quiescent current	$I_{reg4} = 10$ mA	-	-	5	mA
PSRR	Supply voltage ripple rejection	$f = 1$ kHz; $V_{in1} = 1.5$ Vpp; $I_o = 800$ mA	48	-	-	dB
V_{drop}	Drop out voltage	$I_{reg4} = 800$ mA ⁽¹⁾	-	-	2.65	V
I_m	Current limit	$R_{short} = 0.5 \Omega$	0.9	-	2	A
Power switch						
V_{dropSW}	Drop voltage power switch	$I_{dcSW} = 1.8$ A max.	-	-	0.5	V
I_{pSW1}	Peak current power switch	Peak time < 10 ms	2	-	3.5	A
I_{pSW2}		Peak time > 40 ms	1	-	2	A
SW_{DEL}	Delay Protection	-	15	-	45	ms
Reset buffer (with push-pull buffer)						
RES	RES falling	$V_{reg2} = 5$ V	4.6	4.7	4.8	V
RES	RES rising	$V_{reg2} = 5$ V	4.65	4.8	4.95	V
$V_{HYS(RES)}$	Hysteresis of reset buffer	-	50	-	200	mV
$I_{Hsource(RES)}$	High level source current	Reset = 0 V	1000	1300	1600	μ A
$I_{Lsink(RES)}$	Low level sink current	Reset = 5 V	14	16	18	mA
RES_{delay}	$C_{res} = 47$ nF	-	10	-	60	ms
ΔT_{RES}	Reset rise and fall time	$R = 10$ k Ω $C = 15$ pF	-	-	50	μ s
I_{Charge}	Charge current	$C_{RES} = 0$ V	3	5	10	μ A
$I_{Discharge}$	Discharge current	$C_{RES} = 5$ V	1	-	3	mA
$V_{TH(F)}$	Falling voltage threshold	-	1	1.2	1.4	V
$V_{TH(R)}$	Rising voltage threshold	-	2.5	2.8	3.5	V
V_{ol}	Low level	$I_{SINK(RES)} = 1$ mA	-	0.3	0.5	V
V_{oh}	High level	-	4.5	V_{reg2}	5.5	V
Hold signal						
V_{lowl}	Hold output low for V_{in1} low	Low detection	-	-	9	V
V_{lowh}	Hold output high for V_{in1} normal	Normal high detection	10	-	18	V
V_{lowl}	Hold output low for V_{in1} high	low detection	22	-	-	V
$V_{HOLD R}$	Low V_{IN1} threshold	V_{IN1} Low TH.	9	9.5	10	V
$V_{HYS (HOLD_L)}$	Hysteresis low TH.	-	50	150	200	mV
$V_{HOLD F}$	High V_{IN1} threshold	V_{IN1} High TH.	18	20	22	V
$V_{HYS (HOLD_M)}$	Hysteresis high TH.	-	50	150	250	mV

L5957

Electrical specifications

Table 4. Electrical characteristics (continued)

Symbol	Parameter	Test condition	Min.	Typ.	Max.	Unit
Ignition buffer (push-pull with schmitt trigger)						
IGN _{IN}	IGN _{out} falling	-	1.03	1.17	1.28	V
IGN _{IN}	IGN _{out} rising	-	1.18	1.27	1.33	V
V _{hys} (IGN _{out})	Hysteresis of ignition buffer	-	30	50	100	mV
I _{Hsource} (IGN _{out})	High level source current	I _{GNout} = 0 V	1000	1500	2000	μA
I _{Lsink} (IGN _{out})	Low level sink current	I _{GNout} = 5 V	10	15	20	mA
V _{ol}	Low level	I _{Lsink} (IGN _{out}) = 1 mA	-	0.3	0.5	V
V _{oh}	High level	-	4.5	Vreg2	5.5	V
IGN _{RISE}	Rising time	C = 15 pF	-	-	10	μs
IGN _{FALL}	Fall time	C = 15 pF	-	-	10	μs
I _{CLAMP}	Input clamp current	V _{CC} < V _{IGN} < 50 V	-	-	2	mA
IGN _{IN}	Input voltage	Operative	0	-	50	V
Enable input (regulators 1,3,4 and power switch)						
V _{TH}	Voltage threshold	-	1.3	-	2.3	V
EN _{IN}	Input voltage	Operative	0	-	5	V

1. Drop condition means that the supply voltage drop down to 100 mV from the regulated output and the regulator is sourcing its maximal load current.

Figure 3. Typical application circuit

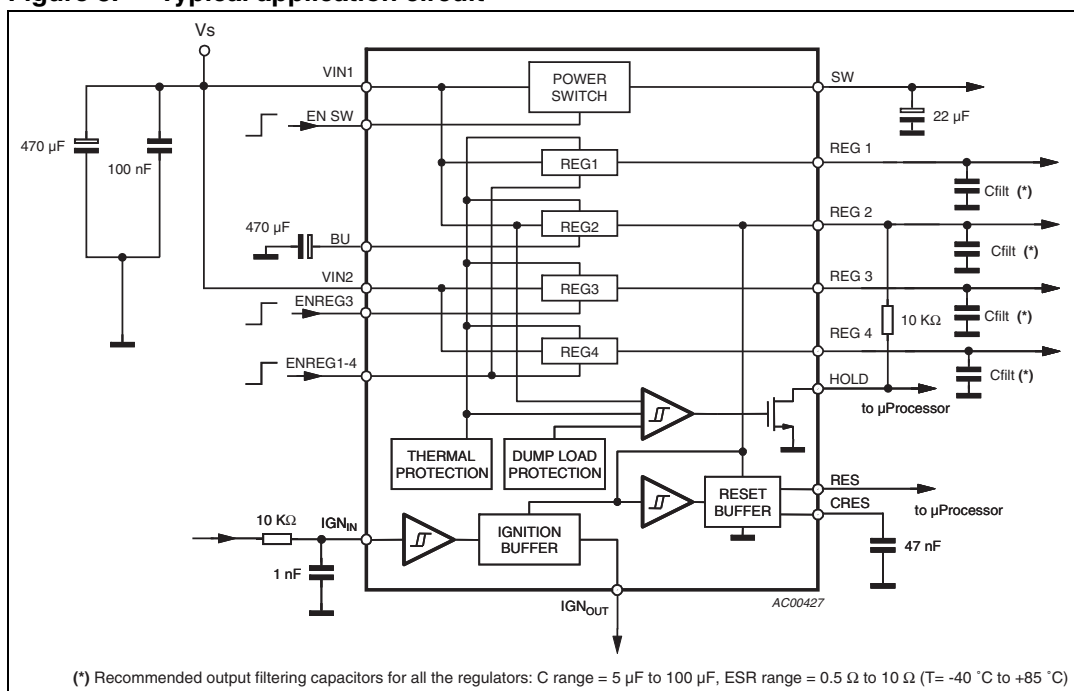

Electrical specifications

L5957

Figure 4. Maximum ESR for stability valid for all the regulators outputs

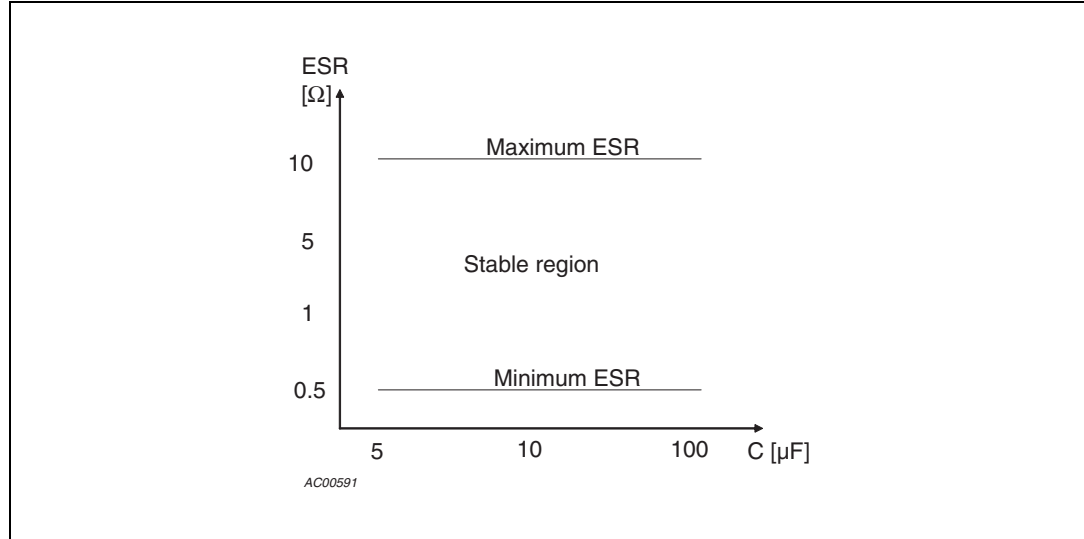

Figure 5. Timing diagram of regulators and power switch

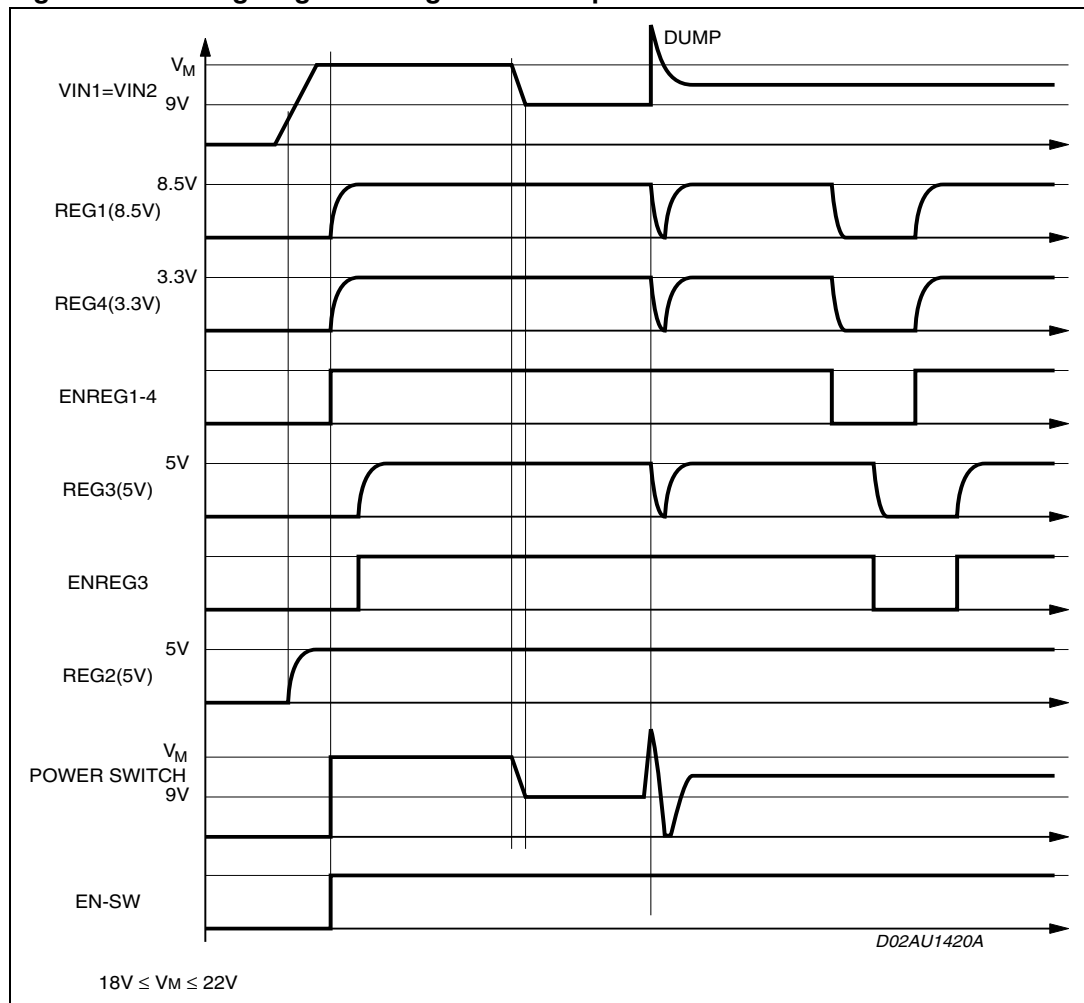

Figure 6. Backup and reset diagram

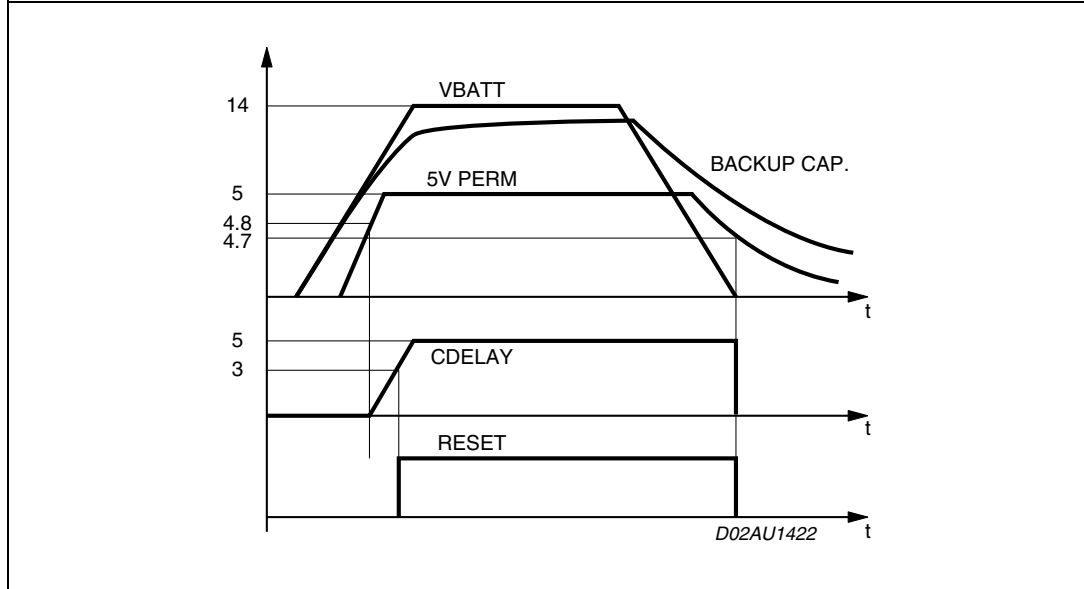
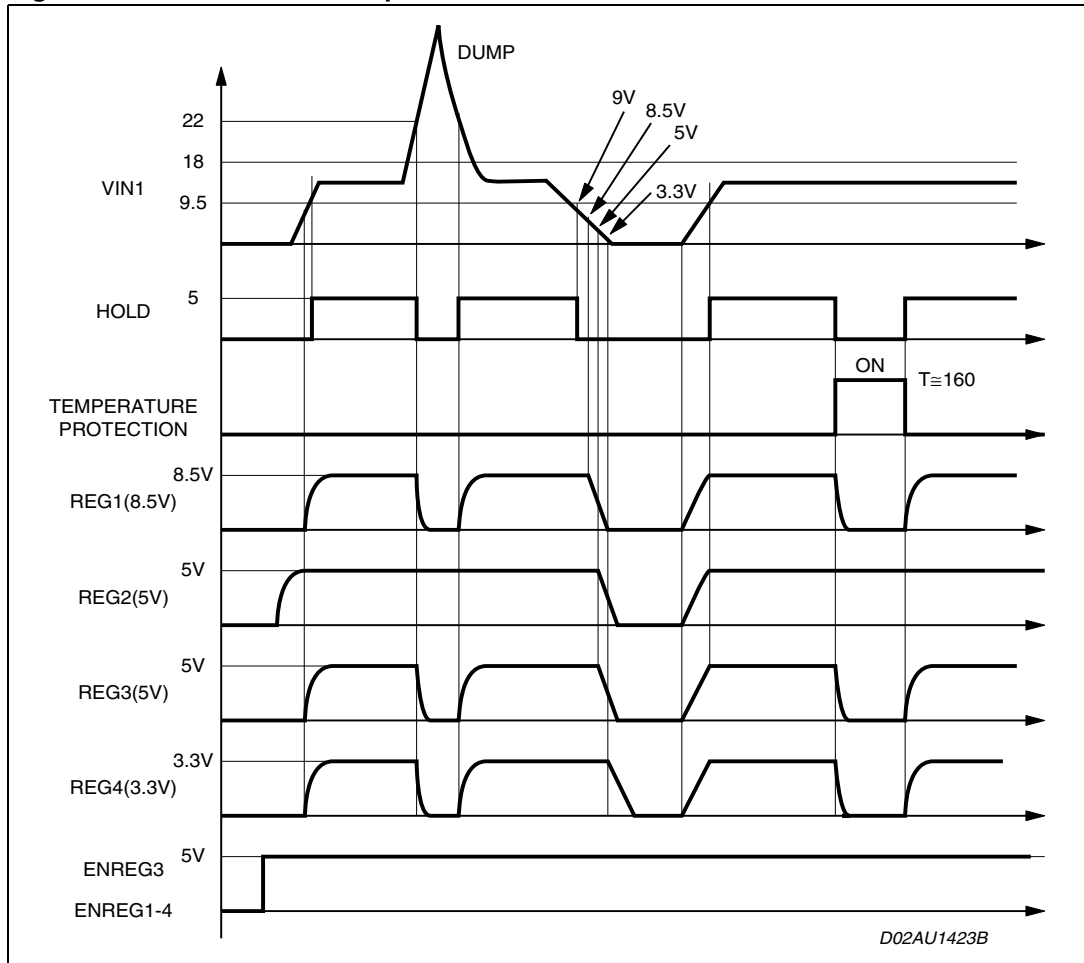

Figure 7. Hold and thermal protection



Electrical specifications

L5957

Figure 8. Ignition buffer diagram

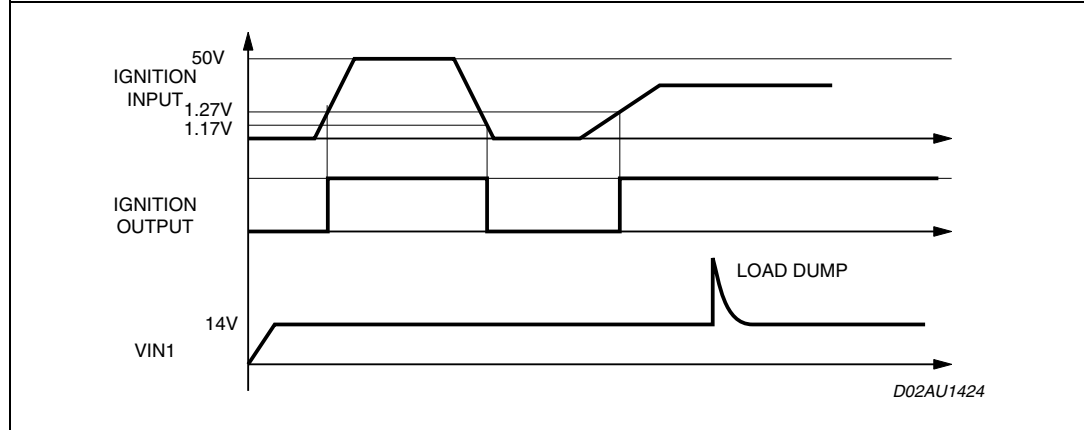

Figure 9. Protection of the power switch

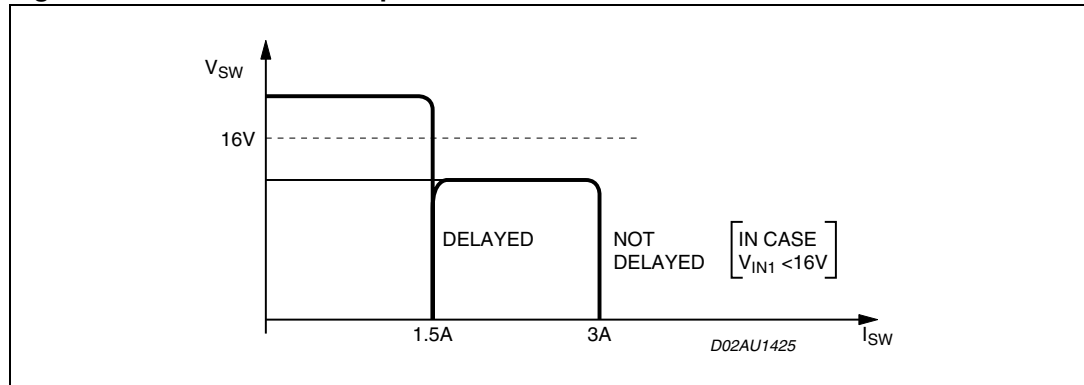
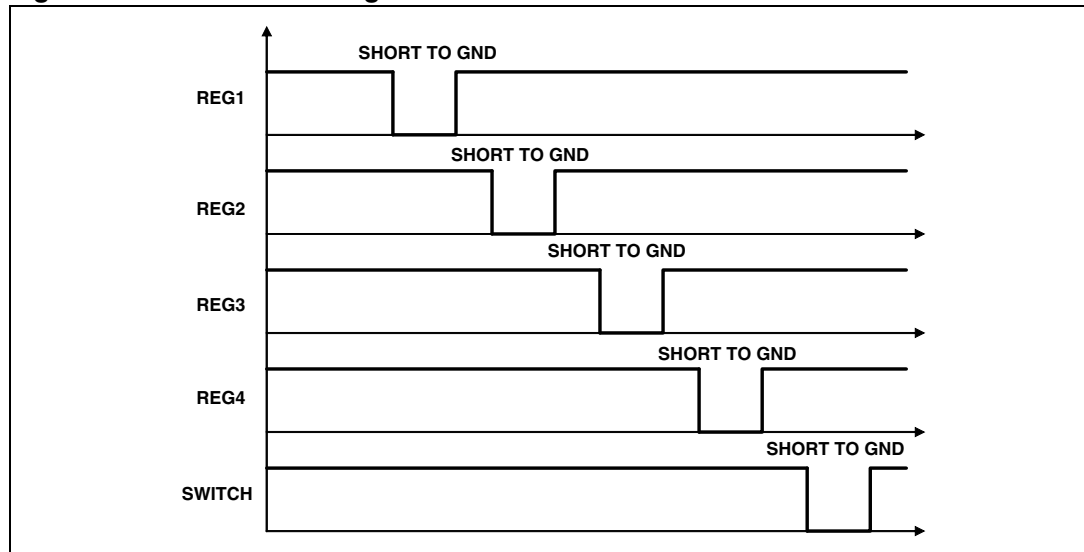

Figure 10. Short circuit diagram



3 Package information

In order to meet environmental requirements, ST offers these devices in different grades of ECOPACK® packages, depending on their level of environmental compliance. ECOPACK® specifications, grade definitions and product status are available at: www.st.com.

ECOPACK® is an ST trademark.

Figure 11. PowerSO20 (slug up) mechanical data and package dimensions

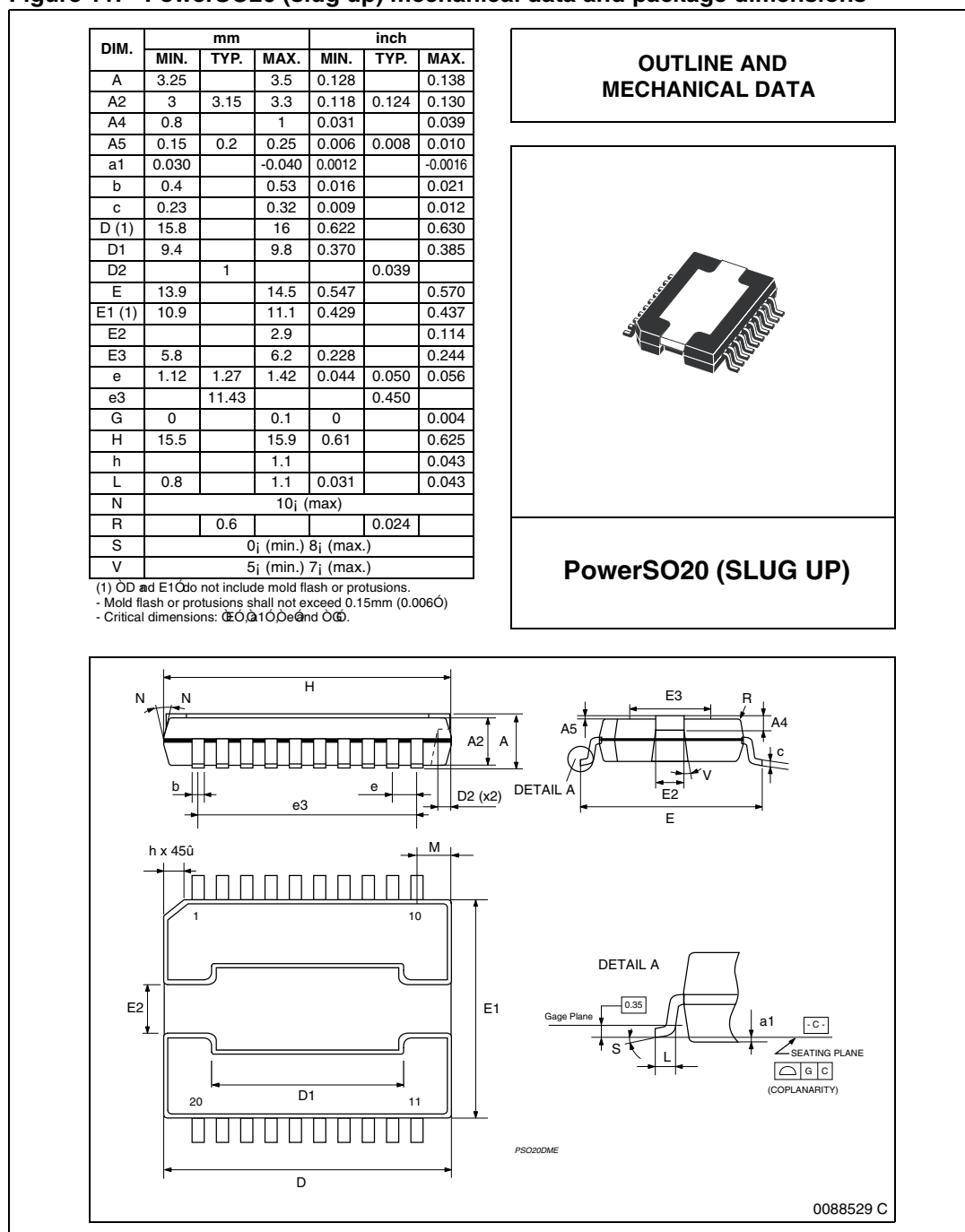

Package information

L5957

Figure 12. Multiwatt15 (vertical) mechanical data and package dimensions

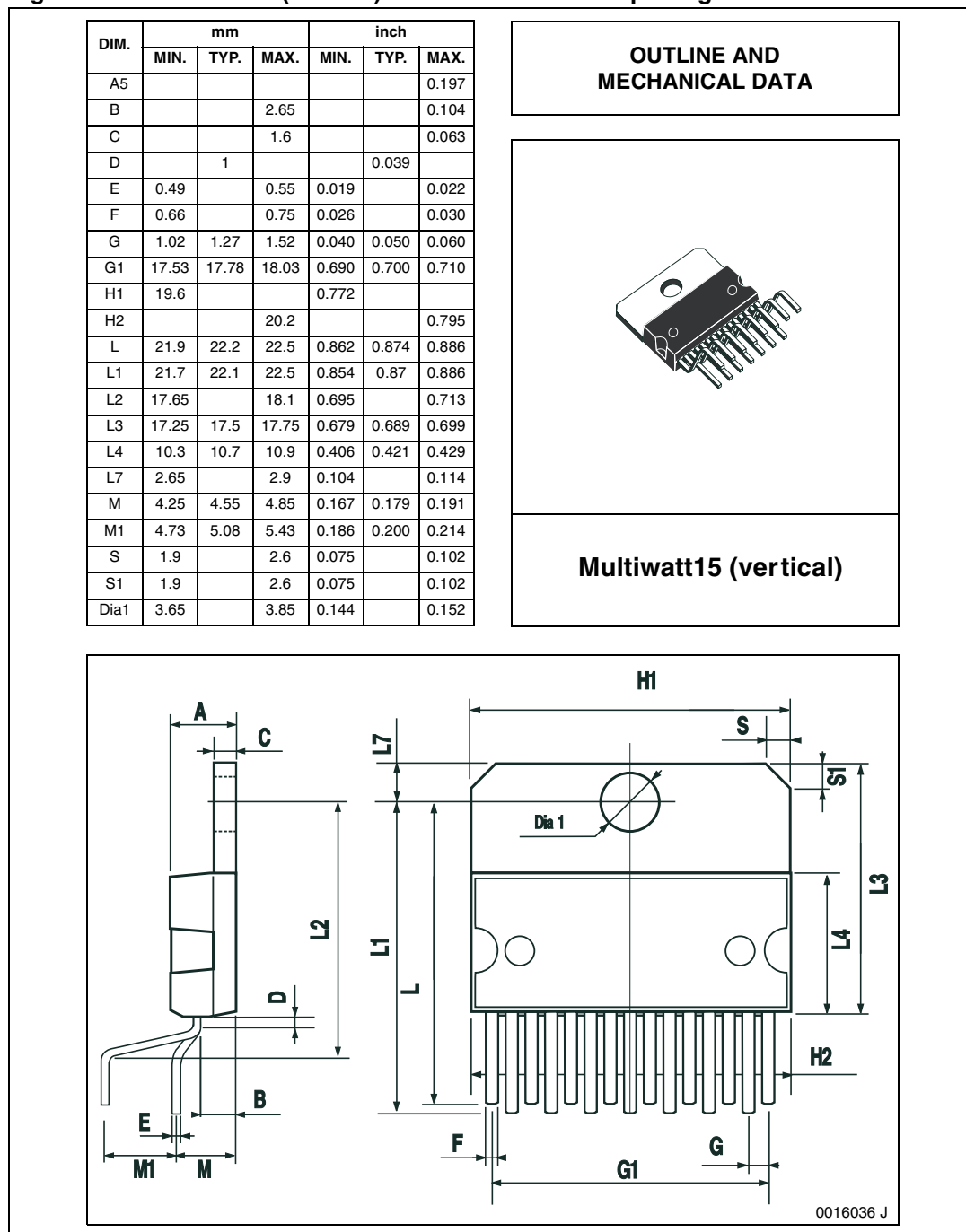

4 Revision history

Table 5. Document revision history

Date	Revision	Changes
11-Feb-2008	1	Initial release.
08-Jan-2010	2	Updated Section 1: Block and pins connection diagrams on page 5 . Updated Figure 3, 5 and 6 .
20-Sep-2013	3	Updated disclaimer.

Please Read Carefully:

Information in this document is provided solely in connection with ST products. STMicroelectronics NV and its subsidiaries ("ST") reserve the right to make changes, corrections, modifications or improvements, to this document, and the products and services described herein at any time, without notice.

All ST products are sold pursuant to ST's terms and conditions of sale.

Purchasers are solely responsible for the choice, selection and use of the ST products and services described herein, and ST assumes no liability whatsoever relating to the choice, selection or use of the ST products and services described herein.

No license, express or implied, by estoppel or otherwise, to any intellectual property rights is granted under this document. If any part of this document refers to any third party products or services it shall not be deemed a license grant by ST for the use of such third party products or services, or any intellectual property contained therein or considered as a warranty covering the use in any manner whatsoever of such third party products or services or any intellectual property contained therein.

UNLESS OTHERWISE SET FORTH IN ST'S TERMS AND CONDITIONS OF SALE ST DISCLAIMS ANY EXPRESS OR IMPLIED WARRANTY WITH RESPECT TO THE USE AND/OR SALE OF ST PRODUCTS INCLUDING WITHOUT LIMITATION IMPLIED WARRANTIES OF MERCHANTABILITY, FITNESS FOR A PARTICULAR PURPOSE (AND THEIR EQUIVALENTS UNDER THE LAWS OF ANY JURISDICTION), OR INFRINGEMENT OF ANY PATENT, COPYRIGHT OR OTHER INTELLECTUAL PROPERTY RIGHT.

ST PRODUCTS ARE NOT DESIGNED OR AUTHORIZED FOR USE IN: (A) SAFETY CRITICAL APPLICATIONS SUCH AS LIFE SUPPORTING, ACTIVE IMPLANTED DEVICES OR SYSTEMS WITH PRODUCT FUNCTIONAL SAFETY REQUIREMENTS; (B) AERONAUTIC APPLICATIONS; (C) AUTOMOTIVE APPLICATIONS OR ENVIRONMENTS, AND/OR (D) AEROSPACE APPLICATIONS OR ENVIRONMENTS. WHERE ST PRODUCTS ARE NOT DESIGNED FOR SUCH USE, THE PURCHASER SHALL USE PRODUCTS AT PURCHASER'S SOLE RISK, EVEN IF ST HAS BEEN INFORMED IN WRITING OF SUCH USAGE, UNLESS A PRODUCT IS EXPRESSLY DESIGNATED BY ST AS BEING INTENDED FOR "AUTOMOTIVE, AUTOMOTIVE SAFETY OR MEDICAL" INDUSTRY DOMAINS ACCORDING TO ST PRODUCT DESIGN SPECIFICATIONS. PRODUCTS FORMALLY ESCC, QML OR JAN QUALIFIED ARE DEEMED SUITABLE FOR USE IN AEROSPACE BY THE CORRESPONDING GOVERNMENTAL AGENCY.

Resale of ST products with provisions different from the statements and/or technical features set forth in this document shall immediately void any warranty granted by ST for the ST product or service described herein and shall not create or extend in any manner whatsoever, any liability of ST.

ST and the ST logo are trademarks or registered trademarks of ST in various countries.

Information in this document supersedes and replaces all information previously supplied.

The ST logo is a registered trademark of STMicroelectronics. All other names are the property of their respective owners.

© 2013 STMicroelectronics - All rights reserved

STMicroelectronics group of companies

Australia - Belgium - Brazil - Canada - China - Czech Republic - Finland - France - Germany - Hong Kong - India - Israel - Italy - Japan - Malaysia - Malta - Morocco - Philippines - Singapore - Spain - Sweden - Switzerland - United Kingdom - United States of America

www.st.com