

Excellent Integrated System Limited

Stocking Distributor

Click to view price, real time Inventory, Delivery & Lifecycle Information:

[STMicroelectronics](#)
[TSV611ICT](#)

For any questions, you can email us directly:

sales@integrated-circuit.com



TSV611, TSV611A, TSV612, TSV612A

Rail-to-rail input/output 10 μ A, 120 kHz
 CMOS operational amplifiers

Features

- Rail-to-rail input and output
- Low power consumption: 10 μ A typ at 5 V
- Low supply voltage: 1.5 to 5.5 V
- Gain bandwidth product: 120 kHz typ
- Unity gain stable
- Low input offset voltage: 800 μ V max (A version)
- Low input bias current: 1 pA typ
- Temperature range: -40 to +85° C

Applications

- Battery-powered applications
- Smoke detectors
- Proximity sensors
- Portable devices
- Signal conditioning
- Active filtering
- Medical instrumentation

Description

The TSV61x family of single and dual operational amplifiers offers low voltage, low power operation and rail-to-rail input and output.

The devices also feature an ultra-low input bias current as well as a low input offset voltage.

The TSV61x have a gain bandwidth product of 120 kHz while consuming only 10 μ A at 5 V.

These features make the TSV61x family ideal for sensor interfaces, battery supplied and portable applications, as well as active filtering.

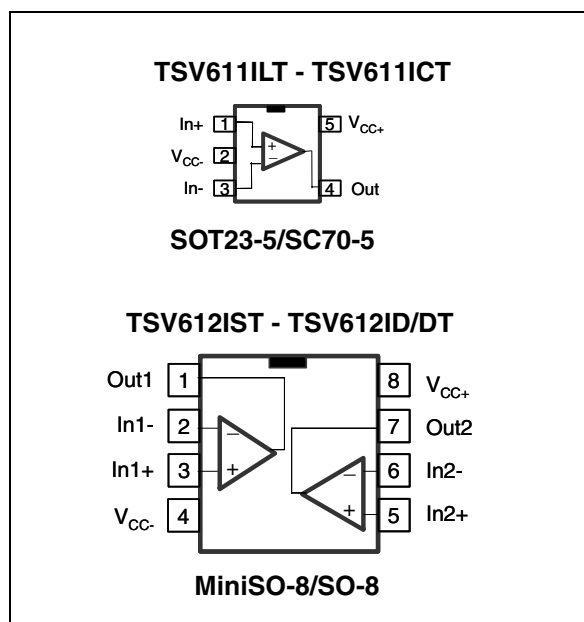

Absolute maximum ratings and operating conditions

TSV611, TSV611A, TSV612, TSV612A

1 Absolute maximum ratings and operating conditions

Table 1. Absolute maximum ratings

| Symbol | Parameter | Value | Unit |
|------------|--|------------------------------------|------|
| V_{CC} | Supply voltage ⁽¹⁾ | 6 | V |
| V_{id} | Differential input voltage ⁽²⁾ | $\pm V_{CC}$ | V |
| V_{in} | Input voltage ⁽³⁾ | $V_{CC-} - 0.2$ to $V_{CC+} + 0.2$ | V |
| T_{stg} | Storage temperature | -65 to +150 | °C |
| R_{thja} | Thermal resistance junction to ambient ⁽⁴⁾⁽⁵⁾ | | °C/W |
| | SC70-5 | 205 | |
| | SOT23-5 | 250 | |
| | MiniSO-8 | 190 | |
| | SO-8 | 125 | |
| T_j | Maximum junction temperature | 150 | °C |
| ESD | HBM: human body model ⁽⁶⁾ | 4 | kV |
| | MM: machine model ⁽⁷⁾ | 200 | V |
| | CDM: charged device model ⁽⁸⁾ | 1.5 | kV |
| | Latch-up immunity | 200 | mA |

- All voltage values, except differential voltage are with respect to network ground terminal.
- Differential voltages are the non-inverting input terminal with respect to the inverting input terminal.
- V_{CC} - V_{in} must not exceed 6 V.
- Short-circuits can cause excessive heating and destructive dissipation.
- R_{th} are typical values.
- Human body model: 100 pF discharged through a 1.5 kΩ resistor between two pins of the device, done for all couples of pin combinations with other pins floating.
- Machine model: a 200 pF cap is charged to the specified voltage, then discharged directly between two pins of the device with no external series resistor (internal resistor < 5 Ω), done for all couples of pin combinations with other pins floating.
- Charged device model: all pins plus package are charged together to the specified voltage and then discharged directly to ground.

Table 2. Operating conditions

| Symbol | Parameter | Value | Unit |
|------------|--------------------------------------|------------------------------------|------|
| V_{CC} | Supply voltage | 1.5 to 5.5 | V |
| V_{icm} | Common mode input voltage range | $V_{CC-} - 0.1$ to $V_{CC+} + 0.1$ | V |
| T_{oper} | Operating free air temperature range | -40 to +85 | °C |

TSV611, TSV611A, TSV612, TSV612A

Electrical characteristics

2 Electrical characteristics

Table 3. Electrical characteristics at $V_{CC+} = +1.8\text{ V}$ with $V_{CC-} = 0\text{ V}$, $V_{icm} = V_{CC}/2$, $T_{amb} = 25^\circ\text{ C}$, and R_L connected to $V_{CC}/2$ (unless otherwise specified)

| Symbol | Parameter | Conditions | Min. | Typ. | Max. | Unit |
|-----------------------|--|--|----------|------|------------|------------------------------|
| DC performance | | | | | | |
| V_{io} | Offset voltage | TSV61x | | | 4 | mV |
| | | TSV61xA | | | 0.8 | |
| | | $T_{min.} < T_{op} < T_{max.}$ TSV61x | | | 5 | |
| | | $T_{min.} < T_{op} < T_{max.}$ TSV61xA | | | 2 | |
| DV_{io} | Input offset voltage drift | | | 2 | | $\mu\text{V}/^\circ\text{C}$ |
| I_{io} | Input offset current ($V_{out} = V_{CC}/2$) | | | 1 | $10^{(1)}$ | pA |
| | | $T_{min.} < T_{op} < T_{max.}$ | | 1 | 100 | pA |
| I_{ib} | Input bias current ($V_{out} = V_{CC}/2$) | | | 1 | $10^{(1)}$ | pA |
| | | $T_{min.} < T_{op} < T_{max.}$ | | 1 | 100 | pA |
| CMR | Common mode rejection ratio $20 \log(\Delta V_{ic}/\Delta V_{io})$ | 0 V to 1.8 V, $V_{out} = 0.9\text{ V}$ | 55 | 71 | | dB |
| | | $T_{min.} < T_{op} < T_{max.}$ | 53 | | | dB |
| A_{vd} | Large signal voltage gain | $R_L = 10\text{ k}\Omega$, $V_{out} = 0.5\text{ V}$ to 1.3 V | 78 | 83 | | dB |
| | | $T_{min.} < T_{op} < T_{max.}$ | 74 | | | dB |
| V_{OH} | High level output voltage | $R_L = 10\text{ k}\Omega$ $T_{min.} < T_{op} < T_{max.}$ | 35 50 | 4 | | mV |
| V_{OL} | Low level output voltage | $R_L = 10\text{ k}\Omega$ $T_{min.} < T_{op} < T_{max.}$ | | 7 | 35 50 | mV |
| I_{out} | Isink | $V_o = 1.8\text{ V}$ $T_{min.} < T_{op} < T_{max.}$ | 9 9 | 13 | | mA |
| | Isource | $V_o = 0\text{ V}$ $T_{min.} < T_{op} < T_{max.}$ | 8 8 | 10 | | |
| I_{CC} | Supply current (per operator) | No load, $V_{out} = V_{CC}/2$ | 6.5 | 9 | 12 | μA |
| | | $T_{min.} < T_{op} < T_{max.}$ | 6 | | 12.5 | μA |
| AC performance | | | | | | |
| GBP | Gain bandwidth product | $R_L = 10\text{ k}\Omega$, $C_L = 20\text{ pF}$ | | 100 | | kHz |
| ϕ_m | Phase margin | $R_L = 10\text{ k}\Omega$, $C_L = 20\text{ pF}$ | | 60 | | Degrees |
| G_m | Gain margin | $R_L = 10\text{ k}\Omega$, $C_L = 20\text{ pF}$ | | 9.5 | | dB |
| SR | Slew rate | $R_L = 10\text{ k}\Omega$, $C_L = 20\text{ pF}$, $V_{out} = 0.5\text{ V}$ to 1.3 V | | 0.03 | | $\text{V}/\mu\text{s}$ |

Electrical characteristics

TSV611, TSV611A, TSV612, TSV612A

**Table 3. Electrical characteristics at $V_{CC+} = +1.8\text{ V}$
with $V_{CC-} = 0\text{ V}$, $V_{icm} = V_{CC}/2$, $T_{amb} = 25^\circ\text{ C}$, and R_L connected to $V_{CC}/2$
(unless otherwise specified) (continued)**

| Symbol | Parameter | Conditions | Min. | Typ. | Max. | Unit |
|--------|-----------------------------------|---|------|------|------|------------------------|
| e_n | Equivalent input noise voltage | $f = 1\text{ kHz}$ | | 110 | | $\frac{nV}{\sqrt{Hz}}$ |
| THD+N | Total harmonic distortion + noise | $F_{in} = 1\text{ kHz}$, $A_v = 1$, $V_{out} = 1\text{ V}_{pp}$, $R_L = 100\text{ k}\Omega$, $BW = 22\text{ kHz}$ | | 0.07 | | % |

1. Guaranteed by design.

TSV611, TSV611A, TSV612, TSV612A

Electrical characteristics

Table 4. $V_{CC+} = +3.3\text{ V}$, $V_{CC-} = 0\text{ V}$, $V_{icm} = V_{CC}/2$, $T_{amb} = 25^\circ\text{ C}$, R_L connected to $V_{CC}/2$ (unless otherwise specified)

| Symbol | Parameter | | Min. | Typ. | Max. | Unit |
|-----------------------|---|---|----------|-------|------------|--------------------------------------|
| DC performance | | | | | | |
| V_{io} | Offset voltage | TSV61x | | | 4 | mV |
| | | TSV61xA | | | 0.8 | |
| | | $T_{min} < T_{op} < T_{max}$ TSV61x | | | 5 | |
| | | $T_{min} < T_{op} < T_{max}$ TSV61xA | | | 2 | |
| DV_{io} | Input offset voltage drift | | | 2 | | $\mu\text{V}/^\circ\text{C}$ |
| I_{io} | Input offset current | | | 1 | $10^{(1)}$ | pA |
| | | $T_{min} < T_{op} < T_{max}$. | | 1 | 100 | pA |
| I_{ib} | Input bias current | | | 1 | $10^{(1)}$ | pA |
| | | $T_{min} < T_{op} < T_{max}$. | | 1 | 100 | pA |
| CMR | Common mode rejection ratio $20 \log (\Delta V_{ic}/\Delta V_{io})$ | 0 V to 3.3 V, $V_{out} = 1.75\text{ V}$ | 61 | 76 | | dB |
| | | $T_{min} < T_{op} < T_{max}$. | 58 | | | dB |
| A_{vd} | Large signal voltage gain | $R_L = 10\text{ k}\Omega$, $V_{out} = 0.5\text{ V}$ to 2.8 V | 85 | 92 | | dB |
| | | $T_{min} < T_{op} < T_{max}$. | 83 | | | dB |
| V_{OH} | High level output voltage | $R_L = 10\text{ k}\Omega$ $T_{min} < T_{op} < T_{max}$. | 35 50 | 5 | | mV |
| V_{OL} | Low level output voltage | $R_L = 10\text{ k}\Omega$ $T_{min} < T_{op} < T_{max}$. | | 10 | 35 50 | mV |
| I_{out} | Isink | $V_o = V_{CC}$ $T_{min} < T_{op} < T_{max}$. | 37 35 | 44 | | mA |
| | Isource | $V_o = 0\text{ V}$ $T_{min} < T_{op} < T_{max}$. | 32 30 | 38 | | |
| I_{CC} | Supply current (per operator) | No load, $V_{out} = V_{CC}/2$ | 6.5 | 9.5 | 12.5 | μA |
| | | $T_{min} < T_{op} < T_{max}$. | 6 | | 13 | μA |
| AC performance | | | | | | |
| GBP | Gain bandwidth product | $R_L = 10\text{ k}\Omega$, $C_L = 20\text{ pF}$ | | 110 | | kHz |
| ϕ_m | Phase margin | $R_L = 10\text{ k}\Omega$, $C_L = 20\text{ pF}$ | | 60 | | Degrees |
| G_m | Gain margin | $R_L = 10\text{ k}\Omega$, $C_L = 20\text{ pF}$, | | 9.5 | | dB |
| SR | Slew rate | $R_L = 10\text{ k}\Omega$, $C_L = 20\text{ pF}$, $V_{out} = 0.5\text{ V}$ to 2.8 V | | 0.035 | | $\text{V}/\mu\text{s}$ |
| e_n | Equivalent input noise voltage | $f = 1\text{ kHz}$ | | 110 | | $\frac{\text{nV}}{\sqrt{\text{Hz}}}$ |

1. Guaranteed by design.

Electrical characteristics
TSV611, TSV611A, TSV612, TSV612A
Table 5. $V_{CC+} = +5\text{ V}$, $V_{CC-} = 0\text{ V}$, $V_{icm} = V_{CC}/2$, $T_{amb} = 25^\circ\text{ C}$, R_L connected to $V_{CC}/2$ (unless otherwise specified)

| Symbol | Parameter | | Min. | Typ. | Max. | Unit |
|-----------------------|--|--|----------|------|------------|------------------------------|
| DC performance | | | | | | |
| V_{io} | Offset voltage | TSV61x | | | 4 | mV |
| | | TSV61xA | | | 0.8 | |
| | | $T_{min} < T_{op} < T_{max}$ TSV61x | | | 5 | |
| | | $T_{min} < T_{op} < T_{max}$ TSV61xA | | | 2 | |
| DV_{io} | Input offset voltage drift | | | 2 | | $\mu\text{V}/^\circ\text{C}$ |
| I_{io} | Input offset current | | | 1 | $10^{(1)}$ | pA |
| | | $T_{min.} < T_{op} < T_{max.}$ | | 1 | 100 | pA |
| I_{ib} | Input bias current | | | 1 | $10^{(1)}$ | pA |
| | | $T_{min.} < T_{op} < T_{max.}$ | | 1 | 100 | pA |
| CMR | Common mode rejection ratio $20 \log (\Delta V_{ic}/\Delta V_{io})$ | 0 V to 5 V, $V_{out} = 2.5\text{ V}$ | 64 | 80 | | dB |
| | | $T_{min.} < T_{op} < T_{max.}$ | 63 | | | dB |
| SVR | Supply voltage rejection ratio $20 \log (\Delta V_{cc}/\Delta V_{io})$ | $V_{cc} = 1.8\text{ to }5\text{ V}$ | 76 | 93 | | dB |
| | | $T_{min.} < T_{op} < T_{max.}$ | 74 | | | dB |
| A_{vd} | Large signal voltage gain | $R_L = 10\text{ k}\Omega$, $V_{out} = 0.5\text{ V to }4.5\text{ V}$ | 88 | 93 | | dB |
| | | $T_{min} < T_{op} < T_{max}$ | 85 | | | dB |
| V_{OH} | High level output voltage | $R_L = 10\text{ k}\Omega$ $T_{min.} < T_{op} < T_{max.}$ | 35 50 | 7 | | mV |
| V_{OL} | Low level output voltage | $R_L = 10\text{ k}\Omega$ $T_{min.} < T_{op} < T_{max.}$ | | 16 | 35 50 | mV |
| I_{out} | Isink | $V_o = V_{CC}$ $T_{min.} < T_{op} < T_{max.}$ | 52 42 | 57 | | mA |
| | Isource | $V_o = 0\text{ V}$ $T_{min.} < T_{op} < T_{max.}$ | 58 49 | 63 | | |
| I_{CC} | Supply current (per operator) | No load, $V_{out} = V_{CC}/2$ | 7.5 | 10.5 | 14 | μA |
| | | $T_{min.} < T_{op} < T_{max.}$ | 7 | | 15 | μA |
| AC performance | | | | | | |
| GBP | Gain bandwidth product | $R_L = 10\text{ k}\Omega$, $C_L = 20\text{ pF}$ | | 120 | | kHz |
| ϕ_m | Phase margin | $R_L = 10\text{ k}\Omega$, $C_L = 20\text{ pF}$ | | 62 | | Degrees |
| G_m | Gain margin | $R_L = 10\text{ k}\Omega$, $C_L = 20\text{ pF}$ | | 10 | | dB |
| SR | Slew rate | $R_L = 10\text{ k}\Omega$, $C_L = 20\text{ pF}$, $V_{out} = 0.5\text{V to }4.5\text{V}$ | | 0.04 | | $\text{V}/\mu\text{s}$ |

TSV611, TSV611A, TSV612, TSV612A

Electrical characteristics

Table 5. $V_{CC+} = +5\text{ V}$, $V_{CC-} = 0\text{ V}$, $V_{icm} = V_{CC}/2$, $T_{amb} = 25^\circ\text{ C}$, R_L connected to $V_{CC}/2$ (unless otherwise specified) (continued)

| Symbol | Parameter | Min. | Typ. | Max. | Unit |
|--------|-----------------------------------|------|------|------|------------------------|
| e_n | Equivalent input noise voltage | | 105 | | $\frac{nV}{\sqrt{Hz}}$ |
| THD+N | Total harmonic distortion + noise | | 0.02 | | % |

Notes for THD+N: $F_{in} = 1\text{ kHz}$, $A_v = 1$, $V_{out} = 1\text{ V}_{pp}$, $R_L = 100\text{ k}\Omega$, $BW = 22\text{ kHz}$

1. Guaranteed by design.

Figure 1. Supply current vs. supply voltage at $V_{icm} = V_{CC}/2$

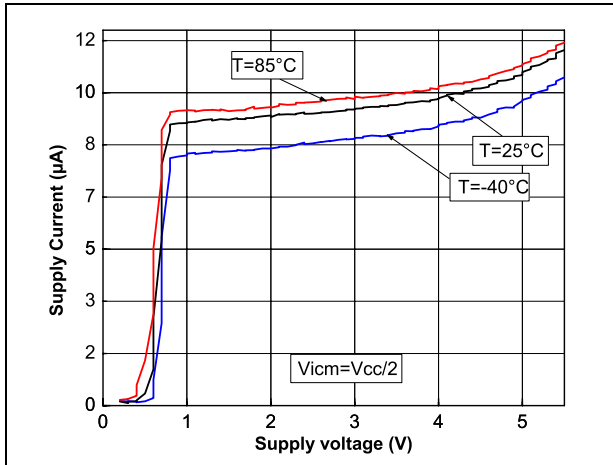

Figure 2. Output current vs. output voltage at $V_{CC} = 1.5\text{ V}$

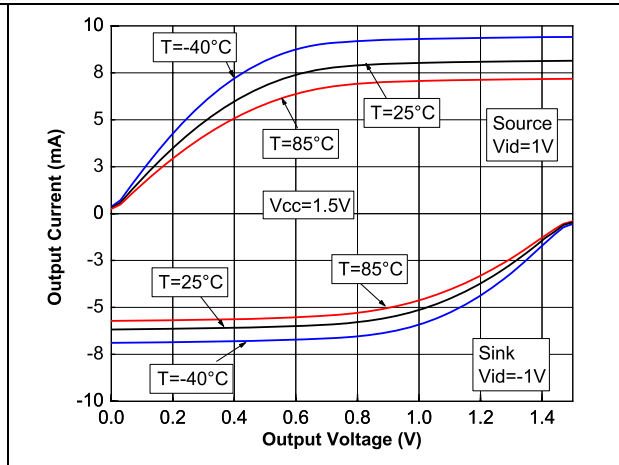

Figure 3. Output current vs. output voltage at $V_{CC} = 5\text{ V}$

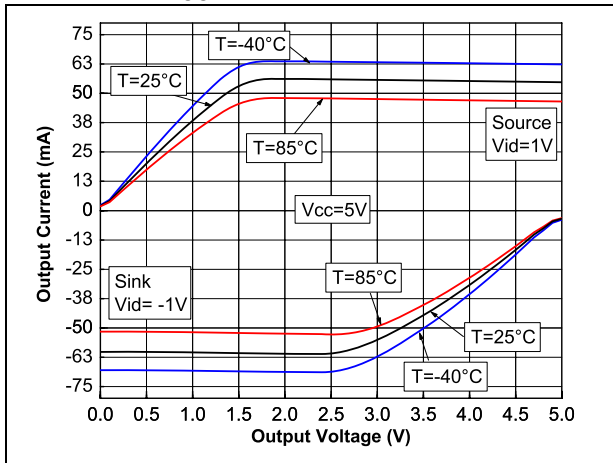
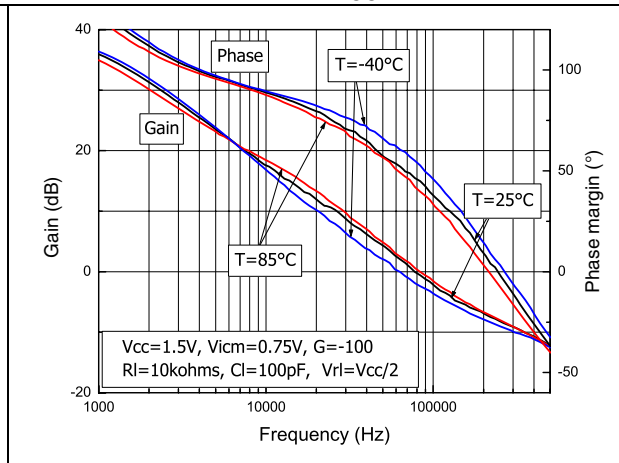

Figure 4. Voltage gain and phase vs. frequency at $V_{CC} = 1.5\text{ V}$



Electrical characteristics

TSV611, TSV611A, TSV612, TSV612A

Figure 5. Voltage gain and phase vs. frequency at $V_{CC} = 5\text{ V}$

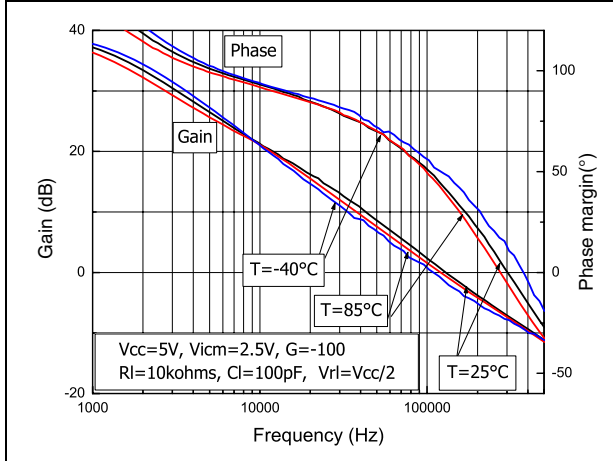

Figure 6. Phase margin vs. output current

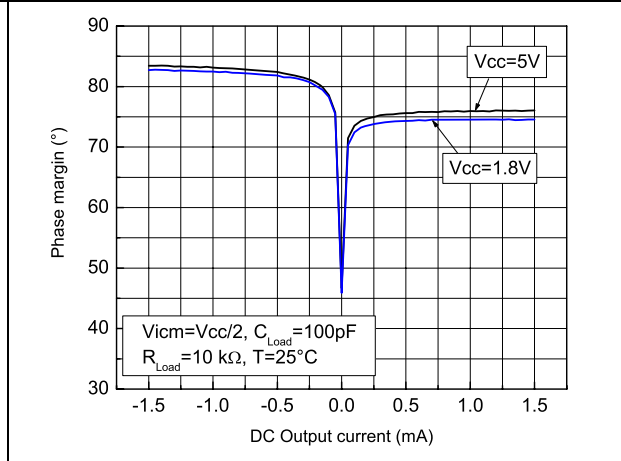

Figure 7. Positive slew rate vs. time, $V_{CC} = 1.5\text{ V}$, $C_{Load} = 100\text{ pF}$, $R_{Load} = 10\text{ k}\Omega$

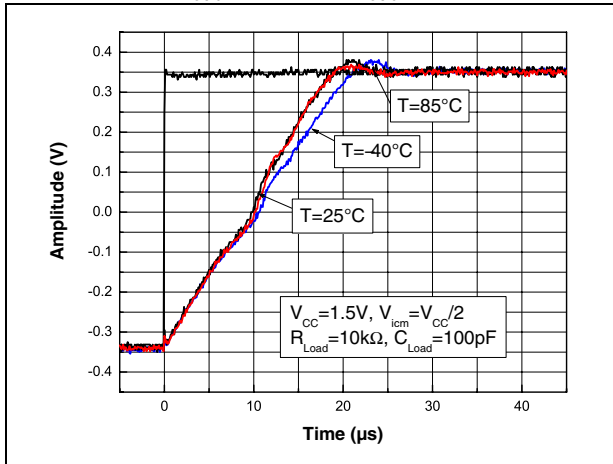

Figure 8. Negative slew rate vs. time, $V_{CC} = 1.5\text{ V}$, $C_{Load} = 100\text{ pF}$, $R_{Load} = 10\text{ k}\Omega$

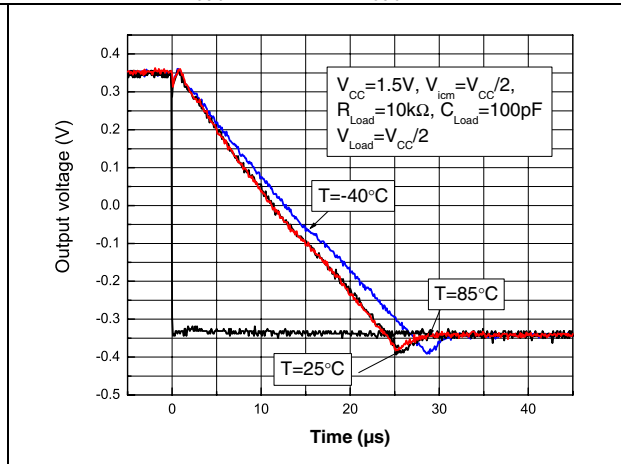

Figure 9. Positive slew rate vs. time, $V_{CC} = 5.5\text{ V}$, $C_{Load} = 100\text{ pF}$, $R_{Load} = 100\text{ k}\Omega$

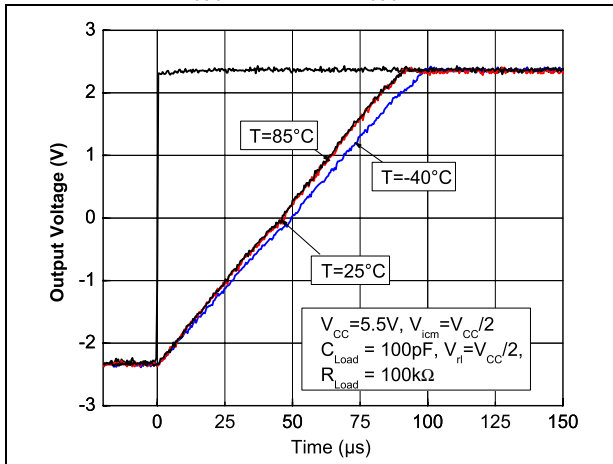
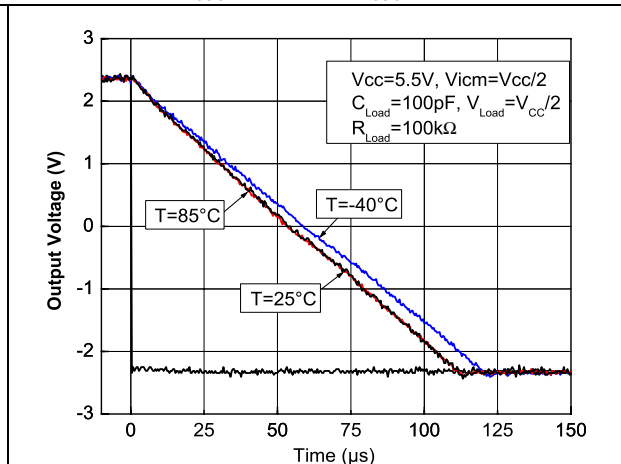

Figure 10. Negative slew rate vs. time, $V_{CC} = 5.5\text{ V}$, $C_{Load} = 100\text{ pF}$, $R_{Load} = 100\text{ k}\Omega$



TSV611, TSV611A, TSV612, TSV612A

Electrical characteristics

Figure 11. Slew rate vs. supply voltage

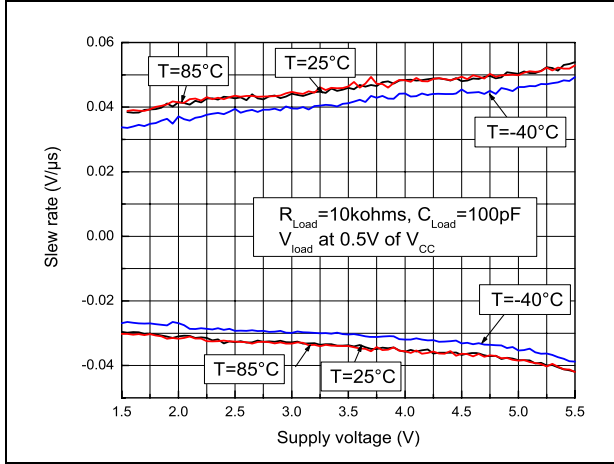

Figure 12. Noise vs. frequency at V_{CC} = 5 V

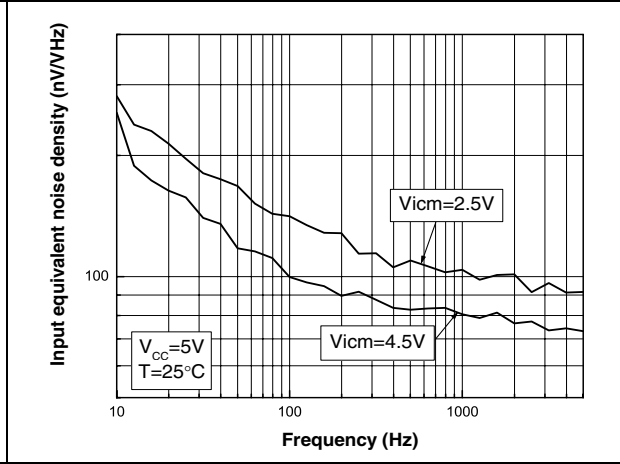

Figure 13. Distortion + noise vs. frequency

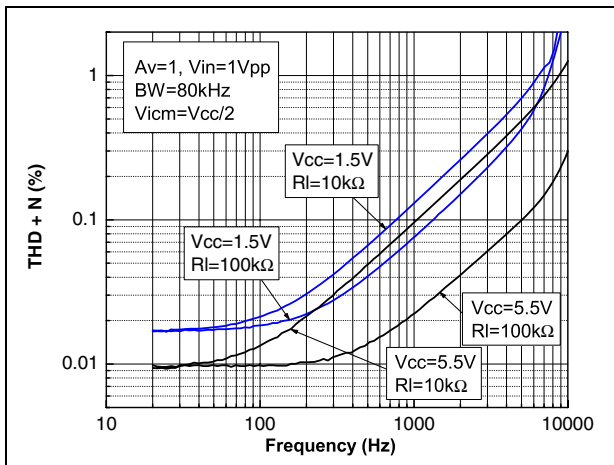

Figure 14. Distortion + noise vs. output voltage

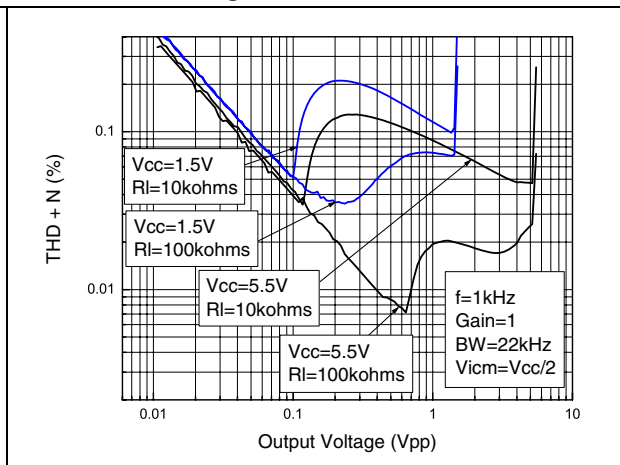

Figure 15. Voltage gain and phase vs. frequency at V_{CC} = 1.8 V (based on simulation results)

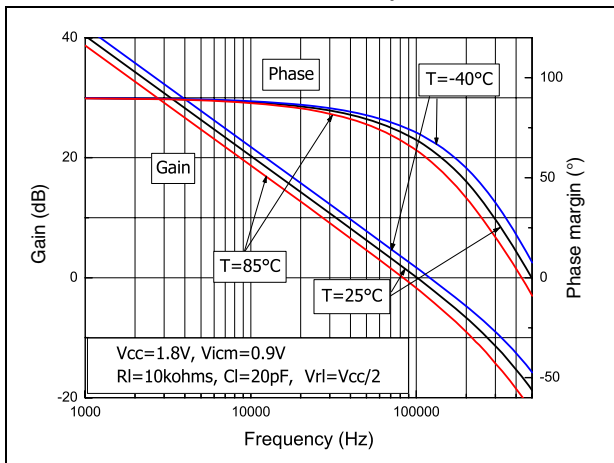
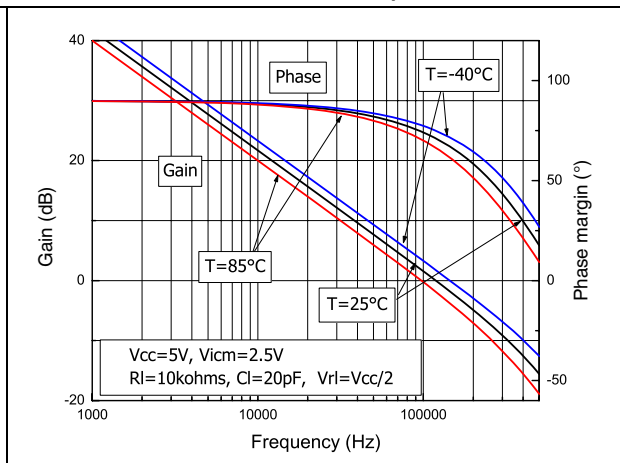

Figure 16. Voltage gain and phase vs. frequency at V_{CC} = 5 V (based on simulation results)



Application information

TSV611, TSV611A, TSV612, TSV612A

3 Application information

3.1 Operating voltages

The TSV61x can operate from 1.5 to 5.5 V. Their parameters are fully specified for 1.8, 3.3 and 5 V power supplies. However, the parameters are very stable in the full V_{CC} range and several characterization curves show the TSV61x characteristics at 1.5 V. Additionally, the main specifications are guaranteed in extended temperature ranges from -40°C to $+85^{\circ}\text{C}$.

3.2 Rail-to-rail input

The TSV61x are built with two complementary PMOS and NMOS input differential pairs. The devices have a rail-to-rail input, and the input common mode range is extended from $V_{CC-} -0.1\text{ V}$ to $V_{CC+} +0.1\text{ V}$. The transition between the two pairs appears at $V_{CC+} -0.7\text{ V}$. In the transition region, the performance of CMRR, PSRR, V_{io} and THD is slightly degraded (as shown in *Figure 17* and *Figure 18* for V_{io} vs. V_{icm}).

Figure 17. Input offset voltage vs input common mode at $V_{CC} = 1.5\text{ V}$

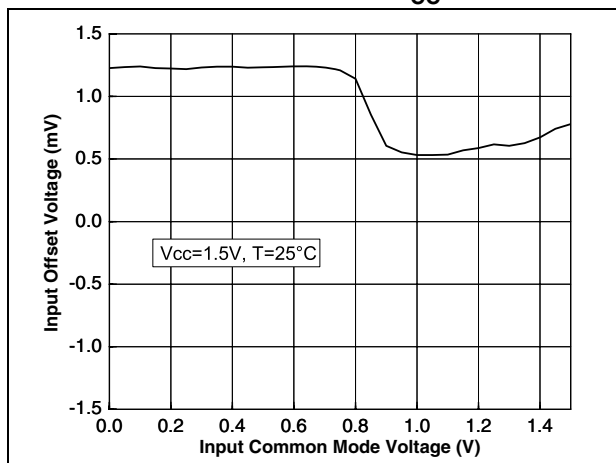
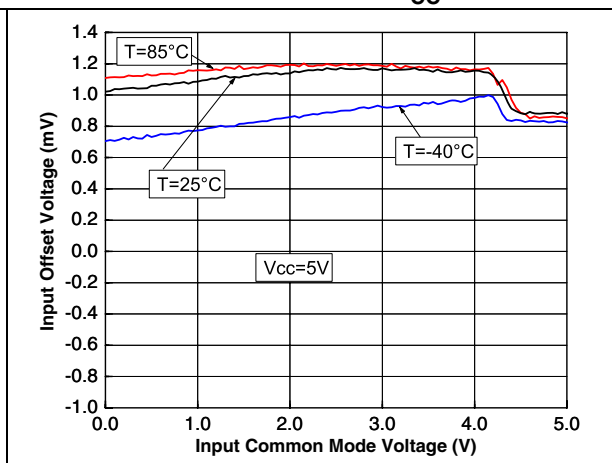

Figure 18. Input offset voltage vs input common mode at $V_{CC} = 5\text{ V}$



The device is guaranteed without phase reversal.

3.3 Rail-to-rail output

The operational amplifiers' output levels can go close to the rails: less than 35 mV above GND rail and less than 35 mV below V_{CC} rail when connected to 10 k Ω load to $V_{CC}/2$.

3.4 Driving resistive and capacitive loads

These products are micro-power, low-voltage operational amplifiers optimized to drive rather large resistive loads, above 10 k Ω . For lower resistive loads, the THD level may significantly increase.

TSV611, TSV611A, TSV612, TSV612A

Application information

In a follower configuration, these operational amplifiers can drive capacitive loads up to 100 pF with no oscillations. When driving larger capacitive loads, adding an in-series resistor at the output can improve the stability of the devices (see [Figure 19](#) for recommended in-series resistor values). Once the in-series resistor value has been selected, the stability of the circuit should be tested on bench and simulated with the simulation model.

Figure 19. In-series resistor vs. capacitive load

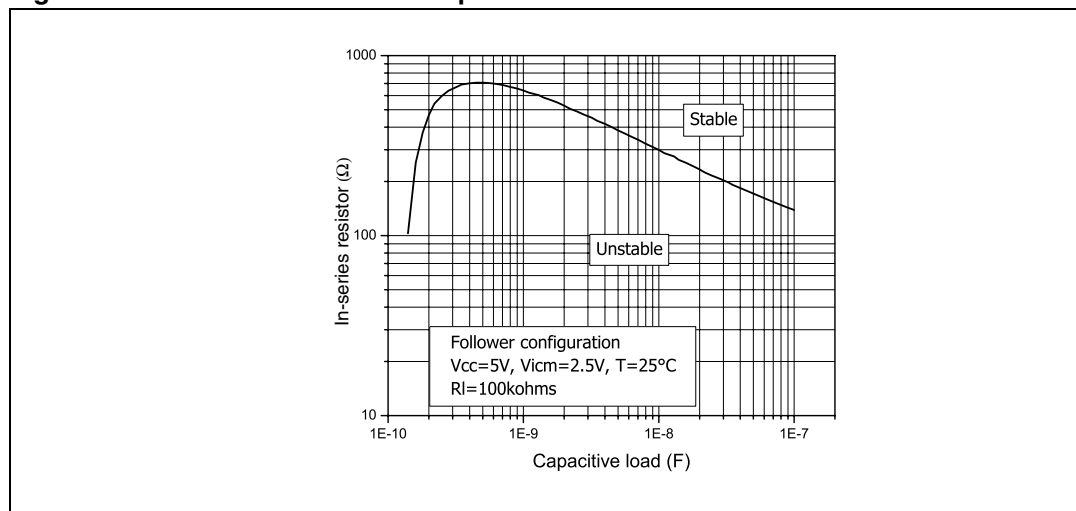

3.5 PCB layouts

For correct operation, it is advised to add 10 nF decoupling capacitors as close as possible to the power supply pins.

3.6 Macromodel

An accurate macromodel of the TSV61x is available on STMicroelectronics' web site at www.st.com. This model is a trade-off between accuracy and complexity (that is, time simulation) of the TSV61x operational amplifiers. It emulates the nominal performances of a typical device within the specified operating conditions mentioned in the datasheet. It also helps to validate a design approach and to select the right operational amplifier, *but it does not replace on-board measurements.*

4 Package information

In order to meet environmental requirements, ST offers these devices in different grades of ECOPACK[®] packages, depending on their level of environmental compliance. ECOPACK[®] specifications, grade definitions and product status are available at: www.st.com. ECOPACK[®] is an ST trademark.

TSV611, TSV611A, TSV612, TSV612A

Package information

4.1 SOT23-5 package information

Figure 20. SOT23-5 package mechanical drawing

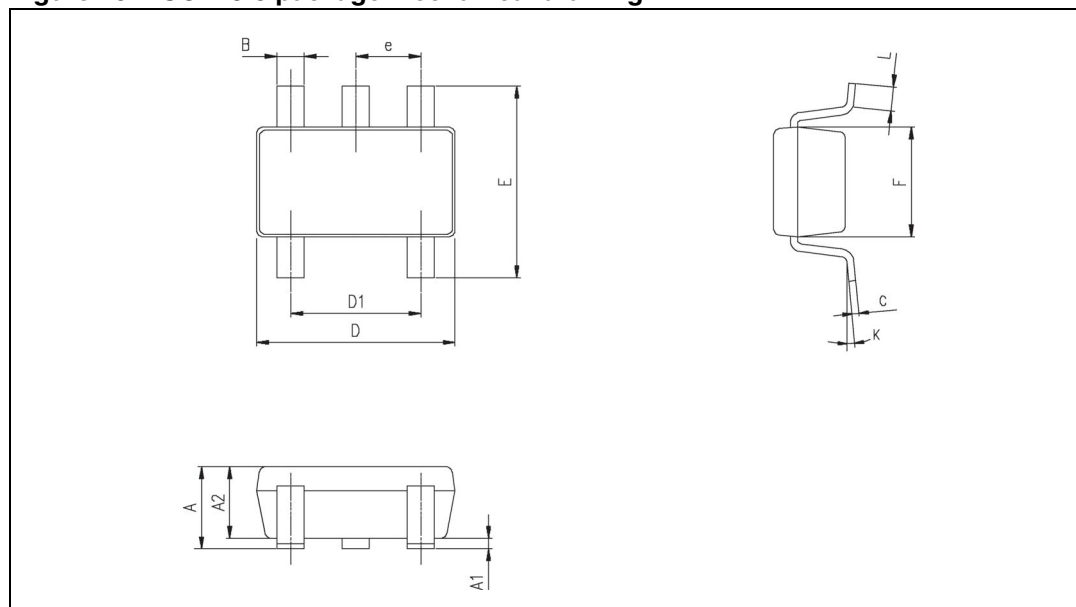

Table 6. SOT23-5 package mechanical data

| Ref. | Dimensions | | | | | |
|------|-------------|------|------------|--------|-------|-------|
| | Millimeters | | | Inches | | |
| | Min. | Typ. | Max. | Min. | Typ. | Max. |
| A | 0.90 | 1.20 | 1.45 | 0.035 | 0.047 | 0.057 |
| A1 | | | 0.15 | | | 0.006 |
| A2 | 0.90 | 1.05 | 1.30 | 0.035 | 0.041 | 0.051 |
| B | 0.35 | 0.40 | 0.50 | 0.013 | 0.015 | 0.019 |
| C | 0.09 | 0.15 | 0.20 | 0.003 | 0.006 | 0.008 |
| D | 2.80 | 2.90 | 3.00 | 0.110 | 0.114 | 0.118 |
| D1 | | 1.90 | | | 0.075 | |
| e | | 0.95 | | | 0.037 | |
| E | 2.60 | 2.80 | 3.00 | 0.102 | 0.110 | 0.118 |
| F | 1.50 | 1.60 | 1.75 | 0.059 | 0.063 | 0.069 |
| L | 0.10 | 0.35 | 0.60 | 0.004 | 0.013 | 0.023 |
| K | 0 degrees | | 10 degrees | | | |

Package information

TSV611, TSV611A, TSV612, TSV612A

4.2 SC70-5 (SOT323-5) package information

Figure 21. SC70-5 (SOT323-5) package mechanical drawing

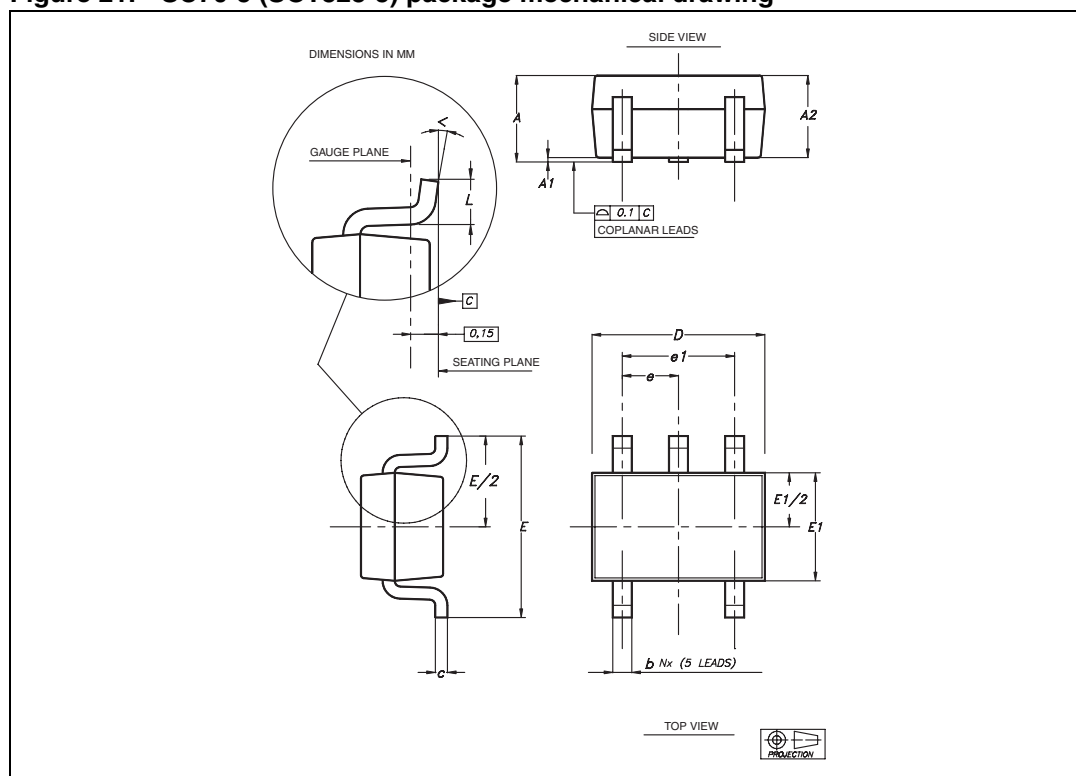

Table 7. SC70-5 (SOT323-5) package mechanical data

| Ref | Dimensions | | | | | |
|-----|-------------|------|------|--------|-------|-------|
| | Millimeters | | | Inches | | |
| | Min | Typ | Max | Min | Typ | Max |
| A | 0.80 | | 1.10 | 0.315 | | 0.043 |
| A1 | | | 0.10 | | | 0.004 |
| A2 | 0.80 | 0.90 | 1.00 | 0.315 | 0.035 | 0.039 |
| b | 0.15 | | 0.30 | 0.006 | | 0.012 |
| c | 0.10 | | 0.22 | 0.004 | | 0.009 |
| D | 1.80 | 2.00 | 2.20 | 0.071 | 0.079 | 0.087 |
| E | 1.80 | 2.10 | 2.40 | 0.071 | 0.083 | 0.094 |
| E1 | 1.15 | 1.25 | 1.35 | 0.045 | 0.049 | 0.053 |
| e | | 0.65 | | | 0.025 | |
| e1 | | 1.30 | | | 0.051 | |
| L | 0.26 | 0.36 | 0.46 | 0.010 | 0.014 | 0.018 |
| < | 0° | | 8° | | | |

TSV611, TSV611A, TSV612, TSV612A

Package information

4.3 SO-8 package information

Figure 22. SO-8 package mechanical drawing

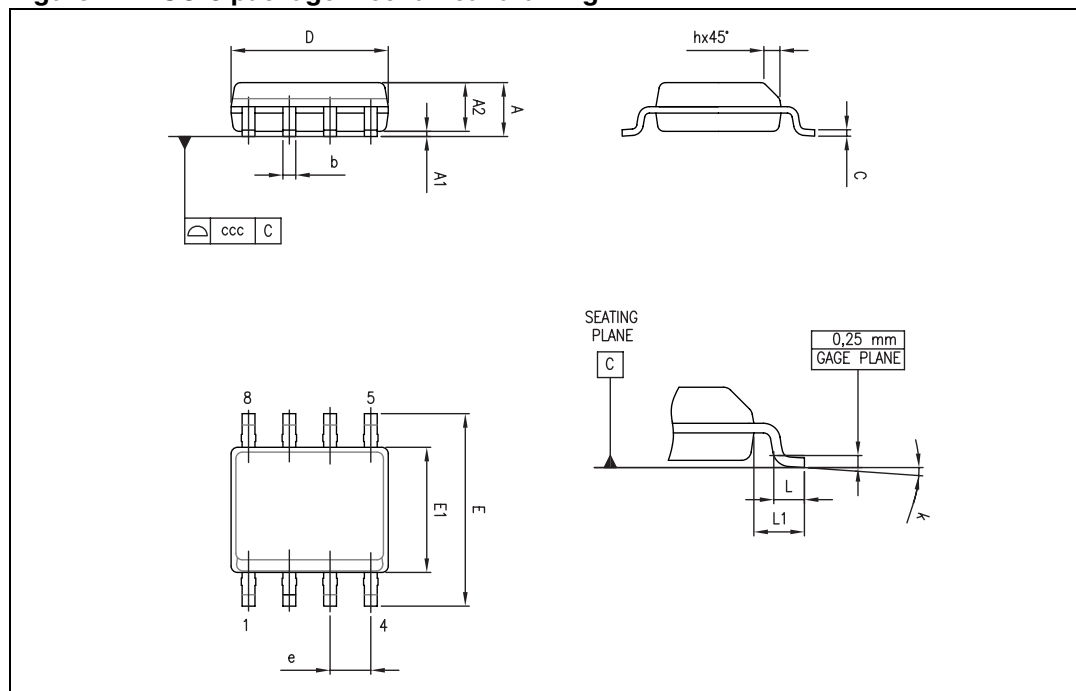

Table 8. SO-8 package mechanical data

| Ref. | Dimensions | | | | | |
|------|-------------|------|------|--------|-------|-------|
| | Millimeters | | | Inches | | |
| | Min. | Typ. | Max. | Min. | Typ. | Max. |
| A | | | 1.75 | | | 0.069 |
| A1 | 0.10 | | 0.25 | 0.004 | | 0.010 |
| A2 | 1.25 | | | 0.049 | | |
| b | 0.28 | | 0.48 | 0.011 | | 0.019 |
| c | 0.17 | | 0.23 | 0.007 | | 0.010 |
| D | 4.80 | 4.90 | 5.00 | 0.189 | 0.193 | 0.197 |
| E | 5.80 | 6.00 | 6.20 | 0.228 | 0.236 | 0.244 |
| E1 | 3.80 | 3.90 | 4.00 | 0.150 | 0.154 | 0.157 |
| e | | 1.27 | | | 0.050 | |
| h | 0.25 | | 0.50 | 0.010 | | 0.020 |
| L | 0.40 | | 1.27 | 0.016 | | 0.050 |
| L1 | | 1.04 | | | 0.040 | |
| k | 1° | | 8° | 1° | | 8° |
| ccc | | | 0.10 | | | 0.004 |

Package information

TSV611, TSV611A, TSV612, TSV612A

4.4 MiniSO-8 package information

Figure 23. MiniSO-8 package mechanical drawing

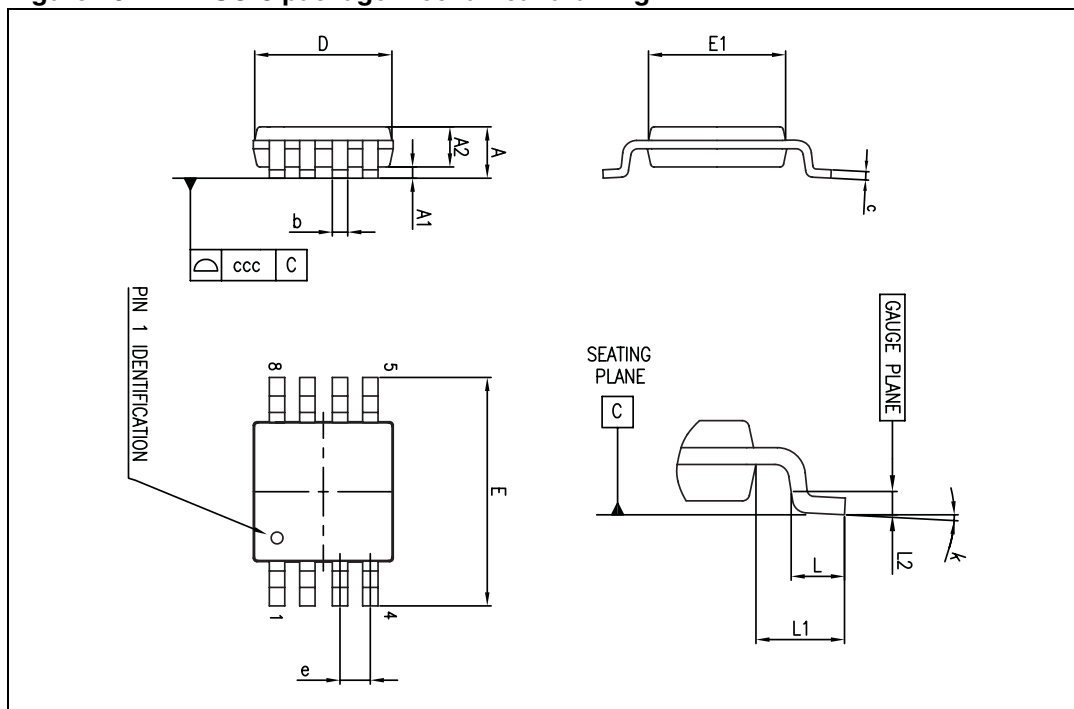

Table 9. MiniSO-8 package mechanical data

| Ref. | Dimensions | | | | | |
|------|-------------|------|------|--------|-------|-------|
| | Millimeters | | | Inches | | |
| | Min. | Typ. | Max. | Min. | Typ. | Max. |
| A | | | 1.1 | | | 0.043 |
| A1 | 0 | | 0.15 | 0 | | 0.006 |
| A2 | 0.75 | 0.85 | 0.95 | 0.030 | 0.033 | 0.037 |
| b | 0.22 | | 0.40 | 0.009 | | 0.016 |
| c | 0.08 | | 0.23 | 0.003 | | 0.009 |
| D | 2.80 | 3.00 | 3.20 | 0.11 | 0.118 | 0.126 |
| E | 4.65 | 4.90 | 5.15 | 0.183 | 0.193 | 0.203 |
| E1 | 2.80 | 3.00 | 3.10 | 0.11 | 0.118 | 0.122 |
| e | | 0.65 | | | 0.026 | |
| L | 0.40 | 0.60 | 0.80 | 0.016 | 0.024 | 0.031 |
| L1 | | 0.95 | | | 0.037 | |
| L2 | | 0.25 | | | 0.010 | |
| k | 0° | | 8° | 0° | | 8° |
| ccc | | | 0.10 | | | 0.004 |

5 Ordering information

Table 10. Order codes

| Order code | Temperature range | Package | Packing | Marking |
|--------------|-------------------|----------|--------------------|---------|
| TSV611ILT | -40° C to 85° C | SOT23-5 | Tape & reel | K12 |
| TSV611AILT | | | | K11 |
| TSV611ICT | | SC70-5 | | K12 |
| TSV611AICT | | | | K11 |
| TSV612ID/DT | | SO-8 | Tube & tape & reel | V612I |
| TSV612AID/DT | | | | V612AI |
| TSV612IST | | MiniSO-8 | Tape & reel | K113 |
| TSV612AIST | | | | K115 |

6 Revision history

Table 11. Document revision history

| Date | Revision | Changes |
|-------------|----------|--|
| 28-May-2009 | 1 | Initial release. |
| 18-Jan-2010 | 2 | Full datasheet for product now in production. Added Figure 1 to Figure 19 . |

TSV611, TSV611A, TSV612, TSV612A

Please Read Carefully:

Information in this document is provided solely in connection with ST products. STMicroelectronics NV and its subsidiaries ("ST") reserve the right to make changes, corrections, modifications or improvements, to this document, and the products and services described herein at any time, without notice.

All ST products are sold pursuant to ST's terms and conditions of sale.

Purchasers are solely responsible for the choice, selection and use of the ST products and services described herein, and ST assumes no liability whatsoever relating to the choice, selection or use of the ST products and services described herein.

No license, express or implied, by estoppel or otherwise, to any intellectual property rights is granted under this document. If any part of this document refers to any third party products or services it shall not be deemed a license grant by ST for the use of such third party products or services, or any intellectual property contained therein or considered as a warranty covering the use in any manner whatsoever of such third party products or services or any intellectual property contained therein.

UNLESS OTHERWISE SET FORTH IN ST'S TERMS AND CONDITIONS OF SALE ST DISCLAIMS ANY EXPRESS OR IMPLIED WARRANTY WITH RESPECT TO THE USE AND/OR SALE OF ST PRODUCTS INCLUDING WITHOUT LIMITATION IMPLIED WARRANTIES OF MERCHANTABILITY, FITNESS FOR A PARTICULAR PURPOSE (AND THEIR EQUIVALENTS UNDER THE LAWS OF ANY JURISDICTION), OR INFRINGEMENT OF ANY PATENT, COPYRIGHT OR OTHER INTELLECTUAL PROPERTY RIGHT.

UNLESS EXPRESSLY APPROVED IN WRITING BY AN AUTHORIZED ST REPRESENTATIVE, ST PRODUCTS ARE NOT RECOMMENDED, AUTHORIZED OR WARRANTED FOR USE IN MILITARY, AIR CRAFT, SPACE, LIFE SAVING, OR LIFE SUSTAINING APPLICATIONS, NOR IN PRODUCTS OR SYSTEMS WHERE FAILURE OR MALFUNCTION MAY RESULT IN PERSONAL INJURY, DEATH, OR SEVERE PROPERTY OR ENVIRONMENTAL DAMAGE. ST PRODUCTS WHICH ARE NOT SPECIFIED AS "AUTOMOTIVE GRADE" MAY ONLY BE USED IN AUTOMOTIVE APPLICATIONS AT USER'S OWN RISK.

Resale of ST products with provisions different from the statements and/or technical features set forth in this document shall immediately void any warranty granted by ST for the ST product or service described herein and shall not create or extend in any manner whatsoever, any liability of ST.

ST and the ST logo are trademarks or registered trademarks of ST in various countries.

Information in this document supersedes and replaces all information previously supplied.

The ST logo is a registered trademark of STMicroelectronics. All other names are the property of their respective owners.

© 2010 STMicroelectronics - All rights reserved

STMicroelectronics group of companies

Australia - Belgium - Brazil - Canada - China - Czech Republic - Finland - France - Germany - Hong Kong - India - Israel - Italy - Japan - Malaysia - Malta - Morocco - Philippines - Singapore - Spain - Sweden - Switzerland - United Kingdom - United States of America

www.st.com