

Excellent Integrated System Limited

Stocking Distributor

Click to view price, real time Inventory, Delivery & Lifecycle Information:

[Harwin Inc.](#)
[H3182-01](#)

For any questions, you can email us directly:
sales@integrated-circuit.com

Customer Information Sheet

DRAWING No.: H3182-XX SHEET 2 OF 2 IF IN DOUBT - ASK (C) NOT TO SCALE THIRD ANGLE PROJECTION ALL DIMENSIONS IN mm

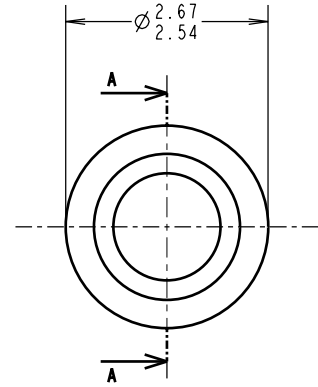
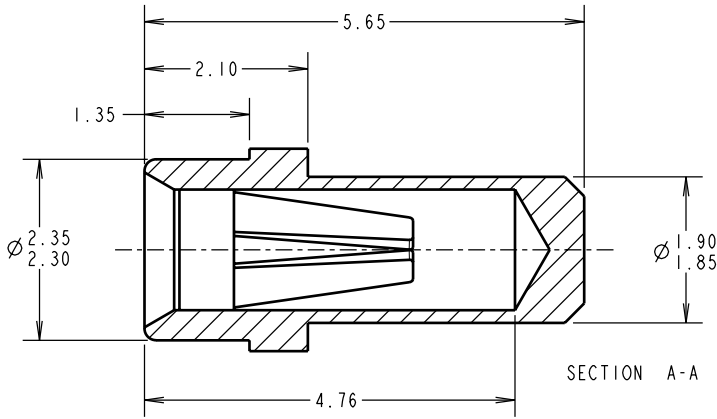

SPECIFICATION:

MATERIAL:
 CONTACT SHELL = BRASS
 CONTACT CLIP = BERYLLIUM COPPER
FINISH:
 01 = 4μ TIN SHELL, 0.15μ GOLD CLIP
 05 = 0.1μ GOLD SHELL, 0.15μ GOLD CLIP
 46 = 4μ 100% TIN SHELL, 3μ 100% TIN CLIP
ELECTRICAL:
 CURRENT RATING AT 25°C = 10A MAX
 CURRENT RATING AT 85°C = 7.5A MAX
 CONTACT RESISTANCE = 25 MILLIOHMS MAX
MECHANICAL:
 INSERTION FORCE (∅1mm GAUGE) = 9N MAX, 3N MIN
 WITHDRAWAL FORCE (∅1mm GAUGE) = 3N MAX, 1N MIN
DURABILITY:
 01, 05 = 1000 OPERATIONS
 46 = 100 OPERATIONS
ENVIRONMENTAL:
 OPERATING TEMPERATURE = -55°C TO +125°C

NOTES:

- FOR COMPLETE SPECIFICATION, SEE COMPONENT SPECIFICATION C009XX (LATEST ISSUE).
- MAXIMUM CONTACT DEPTH = 3.55mm.
- RECOMMENDED MOUNTING HOLE SIZE = ∅2.01-1.91mm.
- RECOMMENDED PIN SIZE = ∅1.05-0.90mm.
- MAXIMUM PIN LENGTH = 4.85mm.

ORDER CODE:

H3182-XX

FINISH:

- 01 = TIN SHELL, GOLD CLIP
- 05 = GOLD SHELL, GOLD CLIP
- 46 = 100% TIN SHELL & TIN CLIP

RA	9	11.02.09	10286
NAME	ISS.	DATE	C/NOTE
APPROVED:		R. ADDE	
CHECKED:			
DRAWN:		I. SANDY	
CUSTOMER REF.:			
ASSEMBLY DRG:			

HARWIN USA TEL: 603 893 5376 FAX: 603 893 5396 mis@harwin.com	HARWIN Europe (UK) TEL: 023 9231 4545 FAX: 023 9231 4590 mis@harwin.co.uk	HARWIN Asia TEL: +65 6 779 4909 FAX: +65 6 779 3868 mis@harwin.com.sg
---	---	---

THIS DRAWING AND ANY INFORMATION OR DESCRIPTIVE MATTER SET OUT HEREON ARE CONFIDENTIAL AND COPYRIGHT PROPERTY OF THE HARWIN GROUP AND MUST NOT BE DISCLOSED, LOANED, COPIED OR USED FOR MANUFACTURING, TENDERING OR FOR ANY OTHER PURPOSE WITHOUT THEIR WRITTEN PERMISSION.

TOLERANCES
 X. = ±1mm
 X.X = ±0.25mm
 X.XX = ±0.10mm
 X.XXX = ±0.01mm
 ANGLES = ±5°
 UNLESS STATED

MATERIAL: SEE ABOVE
FINISH: SEE ABOVE
S/AREA: mm²

TITLE: ∅1.00mm SOCKET ASSEMBLY

DRAWING NUMBER: H3182-XX

SHT
2
OF
2