

## Excellent Integrated System Limited

Stocking Distributor

Click to view price, real time Inventory, Delivery & Lifecycle Information:

[Texas Instruments](#)  
[SN74AUP1T32DCKR](#)

For any questions, you can email us directly:

[sales@integrated-circuit.com](mailto:sales@integrated-circuit.com)

## LOW POWER, 1.8/2.5/3.3-V INPUT, 3.3-V CMOS OUTPUT, 2-INPUT POSITIVE-OR GATE

Check for Samples: [SN74AUP1T32](#)

### FEATURES

- Single-Supply Voltage Translator
- Output Level Up to Supply  $V_{CC}$  CMOS Level
  - 1.8 V to 3.3 V (at  $V_{CC} = 3.3$  V)
  - 2.5 V to 3.3 V (at  $V_{CC} = 3.3$  V)
  - 1.8 V to 2.5 V (at  $V_{CC} = 2.5$  V)
  - 3.3 V to 2.5 V (at  $V_{CC} = 2.5$  V)
- Schmitt-Trigger Inputs Reject Input Noise and Provide Better Output Signal Integrity
- $I_{off}$  Supports Partial Power Down ( $V_{CC} = 0$  V)
- Very Low Static Power Consumption: 0.1  $\mu$ A
- Very Low Dynamic Power Consumption: 0.9  $\mu$ A
- Latch-Up Performance Exceeds 100 mA Per JESD 78, Class II
- Pb-Free Packages Available: SC-70 (DCK) 2 x 2.1 x 0.65 mm (Height 1.1 mm)
- More Gate Options Available at [www.ti.com/littlelogic](http://www.ti.com/littlelogic)
- ESD Performance Tested Per JESD 22
  - 2000-V Human-Body Model (A114-B, Class II)
  - 1000-V Charged-Device Model (C101)

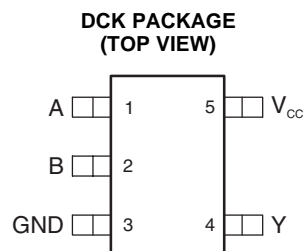

### DESCRIPTION/ORDERING INFORMATION

The SN74AUP1T32 performs the Boolean function  $Y = A + B$  or  $Y = \overline{A} \cdot \overline{B}$  with designation for logic-level translation applications with output referenced to supply  $V_{CC}$ .

AUP technology is the industry's lowest-power logic technology designed for use in extending battery-life in operating. All input levels that accept 1.8-V LVCMOS signals, while operating from either a single 3.3-V or 2.5-V  $V_{CC}$  supply. This product also maintains excellent signal integrity (see [Figure 1](#) and [Figure 2](#)).

The wide  $V_{CC}$  range of 2.3 V to 3.6 V allows the possibility of switching output level to connect to external controllers or processors.

Schmitt-trigger inputs ( $\Delta V_T = 210$  mV between positive and negative input transitions) offer improved noise immunity during switching transitions, which is especially useful on analog mixed-mode designs. Schmitt-trigger inputs reject input noise, ensure integrity of output signals, and allow for slow input signal transition.

$I_{off}$  is a feature that allows for powered-down conditions ( $V_{CC} = 0$  V) and is important in portable and mobile applications. When  $V_{CC} = 0$  V, signals in the range from 0 V to 3.6 V can be applied to the inputs and outputs of the device. No damage occurs to the device under these conditions.

The SN74AUP1T32 is designed with optimized current-drive capability of 4 mA to reduce line reflections, overshoot, and undershoot caused by high-drive outputs.



Please be aware that an important notice concerning availability, standard warranty, and use in critical applications of Texas Instruments semiconductor products and disclaimers thereto appears at the end of this data sheet.

**SN74AUP1T32**



SCES804 – APRIL 2010

www.ti.com

**ORDERING INFORMATION<sup>(1)</sup>**

T <sub>A</sub>	PACKAGE <sup>(2)</sup>	ORDERABLE PART NUMBER	TOP-SIDE MARKING <sup>(3)</sup>
-40°C to 85°C	SOT (SC-70) – DCK	Reel of 3000	SN74AUP1T32DCKR
		Reel of 250	SN74AUP1T32DCKT

- (1) For the most current package and ordering information, see the Package Option Addendum at the end of this document, or see the TI web site at [www.ti.com](http://www.ti.com).
- (2) Package drawings, thermal data, and symbolization are available at [www.ti.com/packaging](http://www.ti.com/packaging).
- (3) The actual top-side marking has one additional character that designates the wafer fab/assembly site.

**FUNCTION TABLE**

INPUTS (Lower Level Input)		OUTPUT (V <sub>CC</sub> CMOS)
A	B	Y
H	X	H
X	H	H
L	L	L

**Supply V<sub>CC</sub> = 2.3 V to 2.7 V (2.5 V)**

INPUTS V <sub>T+</sub> max = V <sub>IH</sub> min V <sub>T-</sub> min = V <sub>IL</sub> max		OUTPUT CMOS
A	B	Y
V <sub>IH</sub> = 1.1 V		V <sub>OH</sub> = 1.85 V
V <sub>IL</sub> = 0.35 V		V <sub>OL</sub> = 0.45 V

**Supply V<sub>CC</sub> = 3 V to 3.6 V (3.3 V)**

INPUTS V <sub>T+</sub> max = V <sub>IH</sub> min V <sub>T-</sub> min = V <sub>IL</sub> max		OUTPUT CMOS
A	B	Y
V <sub>IH</sub> = 1.19 V		V <sub>OH</sub> = 2.55 V
V <sub>IL</sub> = 0.5 V		V <sub>OL</sub> = 0.45 V

**LOGIC DIAGRAM (OR GATE)**

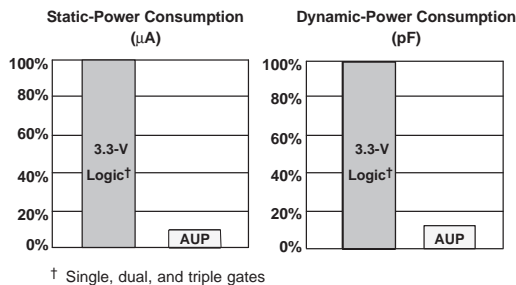

† Single, dual, and triple gates

**Figure 1. AUP – The Lowest-Power Family**

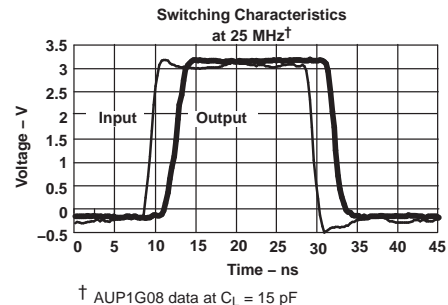

† AUP1G08 data at C<sub>L</sub> = 15 pF

**Figure 2. Excellent Signal Integrity**

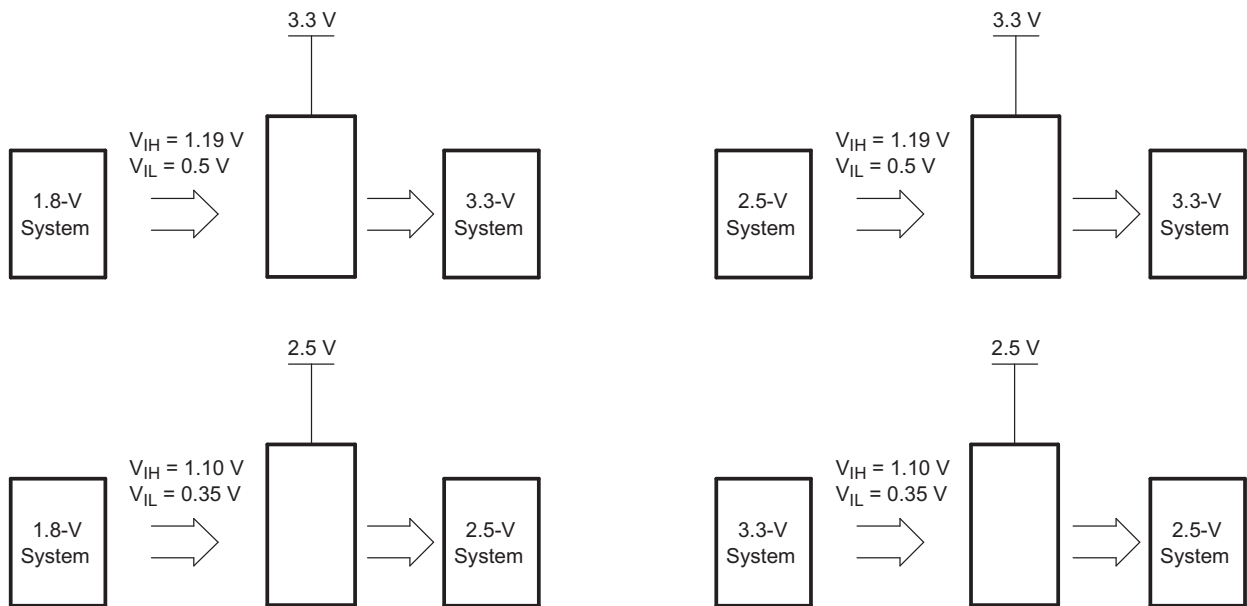

**Figure 3. Typical Design Examples**

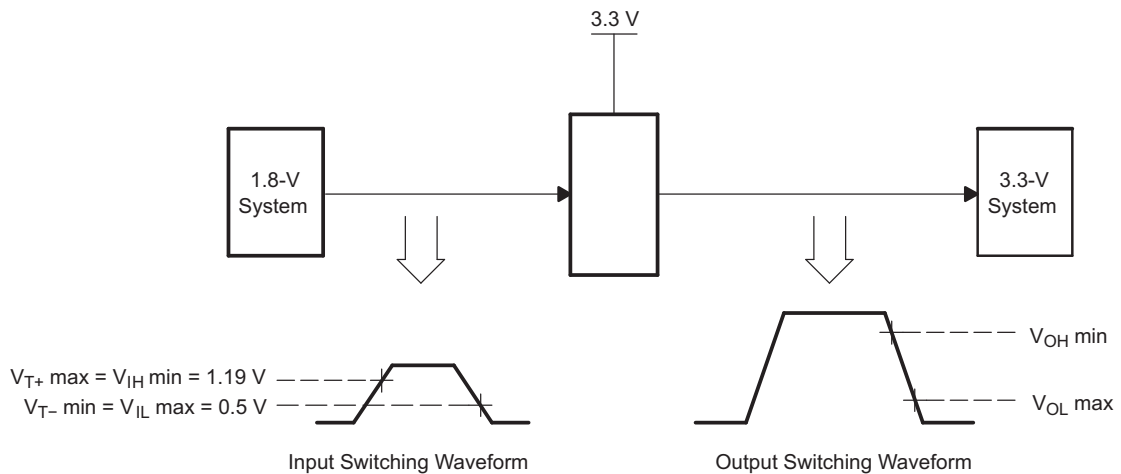

**Figure 4. Switching Thresholds for 1.8-V to 3.3-V Translation**

**SN74AUP1T32**

SCES804 – APRIL 2010

[www.ti.com](http://www.ti.com)
**ABSOLUTE MAXIMUM RATINGS<sup>(1)</sup>**

over operating free-air temperature range (unless otherwise noted)

		MIN	MAX	UNIT
$V_{CC}$	Supply voltage range	-0.5	4.6	V
$V_I$	Input voltage range <sup>(2)</sup>	-0.5	4.6	V
$V_O$	Voltage range applied to any output in the high-impedance or power-off state <sup>(2)</sup>	-0.5	4.6	V
$V_O$	Output voltage range in the high or low state <sup>(2)</sup>	-0.5	$V_{CC} + 0.5$	V
$I_{IK}$	Input clamp current	$V_I < 0$	-50	mA
$I_{OK}$	Output clamp current	$V_O < 0$	-50	mA
$I_O$	Continuous output current		±20	mA
	Continuous current through $V_{CC}$ or GND		±50	mA
$\theta_{JA}$	Package thermal impedance <sup>(3)</sup>	DCK package	259	°C/W
$T_{stg}$	Storage temperature range	-65	150	°C

- (1) Stresses beyond those listed under "absolute maximum ratings" may cause permanent damage to the device. These are stress ratings only, and functional operation of the device at these or any other conditions beyond those indicated under "recommended operating conditions" is not implied. Exposure to absolute-maximum-rated conditions for extended periods may affect device reliability.
- (2) The input negative-voltage and output voltage ratings may be exceeded if the input and output current ratings are observed.
- (3) The package thermal impedance is calculated in accordance with JESD 51-7.

**RECOMMENDED OPERATING CONDITIONS<sup>(1)</sup>**

		MIN	MAX	UNIT
$V_{CC}$	Supply voltage	2.3	3.6	V
$V_I$	Input voltage	0	3.6	V
$V_O$	Output voltage	0	$V_{CC}$	V
$I_{OH}$	High-level output current	$V_{CC} = 2.3\text{ V}$	-3.1	mA
		$V_{CC} = 3\text{ V}$	-4	
$I_{OL}$	Low-level output current	$V_{CC} = 2.3\text{ V}$	3.1	mA
		$V_{CC} = 3\text{ V}$	4	
$T_A$	Operating free-air temperature	-40	85	°C

- (1) All unused inputs of the device must be held at  $V_{CC}$  or GND to ensure proper device operation. See the TI application report *Implications of Slow or Floating CMOS Inputs*, literature number [SCBA004](#).

## ELECTRICAL CHARACTERISTICS

over recommended operating free-air temperature range (unless otherwise noted)

PARAMETER	TEST CONDITIONS	V <sub>CC</sub>	T <sub>A</sub> = 25°C			T <sub>A</sub> = -40°C to 85°C		UNIT	
			MIN	TYP	MAX	MIN	MAX		
V <sub>T+</sub> Positive-going input threshold voltage		2.3 V to 2.7 V	0.6		1.1	0.6	1.1	V	
		3 V to 3.6 V	0.75		1.16	0.75	1.19		
V <sub>T-</sub> Negative-going input threshold voltage		2.3 V to 2.7 V	0.35		0.6	0.35	0.6	V	
		3 V to 3.6 V	0.5		0.85	0.5	0.85		
ΔV <sub>T</sub> Hysteresis (V <sub>T+</sub> - V <sub>T-</sub> )		2.3 V to 2.7 V	0.23		0.6	0.1	0.6	V	
		3 V to 3.6 V	0.25		0.56	0.15	0.56		
V <sub>OH</sub>	I <sub>OH</sub> = -20 μA	2.3 V to 3.6 V	V <sub>CC</sub> - 0.1			V <sub>CC</sub> - 0.1		V	
	I <sub>OH</sub> = -2.3 mA	2.3 V	2.05			1.97			
	I <sub>OH</sub> = -3.1 mA		1.9			1.85			
	I <sub>OH</sub> = -2.7 mA	3 V	2.72			2.67			
	I <sub>OH</sub> = -4 mA		2.6			2.55			
V <sub>OL</sub>	I <sub>OL</sub> = 20 μA	2.3 V to 3.6 V				0.1	0.1	V	
	I <sub>OL</sub> = 2.3 mA	2.3 V				0.31	0.33		
	I <sub>OL</sub> = 3.1 mA					0.44	0.45		
	I <sub>OL</sub> = 2.7 mA	3 V				0.31	0.33		
	I <sub>OL</sub> = 4 mA					0.44	0.45		
I <sub>I</sub>	All inputs	V <sub>I</sub> = 3.6 V or GND	0 V to 3.6 V				0.1	0.5	μA
I <sub>off</sub>		V <sub>I</sub> or V <sub>O</sub> = 0 V to 3.6 V	0 V				0.1	0.5	μA
ΔI <sub>off</sub>		V <sub>I</sub> or V <sub>O</sub> = 3.6 V	0 V to 0.2 V				0.2	0.5	μA
I <sub>CC</sub>		V <sub>I</sub> = 3.6 V or GND, I <sub>O</sub> = 0	2.3 V to 3.6 V				0.5	0.9	μA
ΔI <sub>CC</sub>		One input at 0.3 V or 1.1 V, Other inputs at 0 or V <sub>CC</sub> , I <sub>O</sub> = 0	2.3 V to 2.7 V					4	μA
		One input at 0.45 V or 1.2 V, Other inputs at 0 or V <sub>CC</sub> , I <sub>O</sub> = 0	3 V to 3.6 V					12	
C <sub>i</sub>		V <sub>I</sub> = V <sub>CC</sub> or GND	3.3 V				1.5		pF
C <sub>o</sub>		V <sub>O</sub> = V <sub>CC</sub> or GND	3.3 V				3		pF

## SWITCHING CHARACTERISTICS

 over recommended operating free-air temperature range, V<sub>CC</sub> = 2.5 V ± 0.2 V, V<sub>I</sub> = 1.8 V ± 0.15 V (unless otherwise noted) (see Figure 5)

PARAMETER	FROM (INPUT)	TO (OUTPUT)	C <sub>L</sub>	T <sub>A</sub> = 25°C			T <sub>A</sub> = -40°C to 85°C		UNIT
				MIN	TYP	MAX	MIN	MAX	
t <sub>pd</sub>	A or B	Y	5 pF	1.8	2.3	2.9	0.5	6.8	ns
			10 pF	2.3	2.8	3.4	1	7.9	
			15 pF	2.6	3.1	3.8	1	8.7	
			30 pF	3.8	4.4	5.1	1.5	10.8	

**SN74AUP1T32**

SCES804 – APRIL 2010

[www.ti.com](http://www.ti.com)
**SWITCHING CHARACTERISTICS**

 over recommended operating free-air temperature range,  $V_{CC} = 2.5\text{ V} \pm 0.2\text{ V}$ ,  $V_I = 2.5\text{ V} \pm 0.2\text{ V}$  (unless otherwise noted) (see [Figure 5](#))

PARAMETER	FROM (INPUT)	TO (OUTPUT)	$C_L$	$T_A = 25^\circ\text{C}$			$T_A = -40^\circ\text{C}$ to $85^\circ\text{C}$		UNIT
				MIN	TYP	MAX	MIN	MAX	
$t_{pd}$	A or B	Y	5 pF	1.8	2.3	3.1	0.5	6	ns
			10 pF	2.2	2.8	3.5	1	7.1	
			15 pF	2.6	3.2	5.2	1	7.9	
			30 pF	3.7	4.4	5.2	1.5	10	

**SWITCHING CHARACTERISTICS**

 over recommended operating free-air temperature range,  $V_{CC} = 2.5\text{ V} \pm 0.2\text{ V}$ ,  $V_I = 3.3\text{ V} \pm 0.3\text{ V}$  (unless otherwise noted) (see [Figure 5](#))

PARAMETER	FROM (INPUT)	TO (OUTPUT)	$C_L$	$T_A = 25^\circ\text{C}$			$T_A = -40^\circ\text{C}$ to $85^\circ\text{C}$		UNIT
				MIN	TYP	MAX	MIN	MAX	
$t_{pd}$	A or B	Y	5 pF	2	2.7	3.5	0.5	5.5	ns
			10 pF	2.4	3.1	3.9	1	6.5	
			15 pF	2.8	3.5	4.3	1	7.4	
			30 pF	4	4.7	5.5	1.5	9.5	

**SWITCHING CHARACTERISTICS**

 over recommended operating free-air temperature range,  $V_{CC} = 3.3\text{ V} \pm 0.3\text{ V}$ ,  $V_I = 1.8\text{ V} \pm 0.15\text{ V}$  (unless otherwise noted) (see [Figure 5](#))

PARAMETER	FROM (INPUT)	TO (OUTPUT)	$C_L$	$T_A = 25^\circ\text{C}$			$T_A = -40^\circ\text{C}$ to $85^\circ\text{C}$		UNIT
				MIN	TYP	MAX	MIN	MAX	
$t_{pd}$	A or B	Y	5 pF	1.6	2	2.5	0.5	8	ns
			10 pF	2	2.4	2.9	1	8.5	
			15 pF	2.3	2.8	3.3	1	9.1	
			30 pF	3.4	3.9	4.4	1.5	9.8	

**SWITCHING CHARACTERISTICS**

 over recommended operating free-air temperature range,  $V_{CC} = 3.3\text{ V} \pm 0.3\text{ V}$ ,  $V_I = 2.5\text{ V} \pm 0.2\text{ V}$  (unless otherwise noted) (see [Figure 5](#))

PARAMETER	FROM (INPUT)	TO (OUTPUT)	$C_L$	$T_A = 25^\circ\text{C}$			$T_A = -40^\circ\text{C}$ to $85^\circ\text{C}$		UNIT
				MIN	TYP	MAX	MIN	MAX	
$t_{pd}$	A or B	Y	5 pF	1.6	1.9	2.4	0.5	5.3	ns
			10 pF	2	2.3	2.7	1	6.1	
			15 pF	2.3	2.7	3.1	1	6.8	
			30 pF	3.4	3.8	4.2	1.5	8.5	

### SWITCHING CHARACTERISTICS

over recommended operating free-air temperature range,  $V_{CC} = 3.3\text{ V} \pm 0.3\text{ V}$ ,  $V_I = 3.3\text{ V} \pm 0.3\text{ V}$  (unless otherwise noted) (see Figure 5)

PARAMETER	FROM (INPUT)	TO (OUTPUT)	$C_L$	$T_A = 25^\circ\text{C}$			$T_A = -40^\circ\text{C}$ to $85^\circ\text{C}$		UNIT
				MIN	TYP	MAX	MIN	MAX	
$t_{pd}$	A or B	Y	5 pF	1.6	2.1	2.7	0.5	4.7	ns
			10 pF	2	2.4	3	1	5.7	
			15 pF	2.3	2.7	3.3	1	6.2	
			30 pF	3.4	3.8	4.4	1.5	7.8	

### OPERATING CHARACTERISTICS

$T_A = 25^\circ\text{C}$

PARAMETER	TEST CONDITIONS	$V_{CC} = 2.5\text{ V}$	$V_{CC} = 3.3\text{ V}$	UNIT
		TYP	TYP	
$C_{pd}$ Power dissipation capacitance	$f = 10\text{ MHz}$	4	5	pF



**PARAMETER MEASUREMENT INFORMATION**

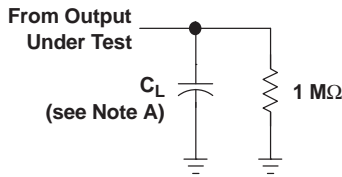

**LOAD CIRCUIT**

	$V_{CC} = 2.5\text{ V}$ $\pm 0.2\text{ V}$	$V_{CC} = 3.3\text{ V}$ $\pm 0.3\text{ V}$
$C_L$	5, 10, 15, 30 pF	5, 10, 15, 30 pF
$V_{MI}$	$V_I/2$	$V_I/2$
$V_{MO}$	$V_{CC}/2$	$V_{CC}/2$

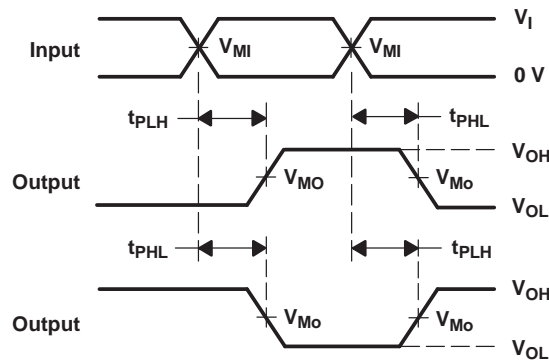

**VOLTAGE WAVEFORMS  
PROPAGATION DELAY TIMES  
INVERTING AND NONINVERTING OUTPUTS**

- NOTES:
- A.  $C_L$  includes probe and jig capacitance.
  - B. All input pulses are supplied by generators having the following characteristics: PRR  $\leq$  10 MHz,  $Z_O = 50\ \Omega$ , slew rate  $\geq$  1 V/ns.
  - C. The outputs are measured one at a time, with one transition per measurement.
  - D.  $t_{PLH}$  and  $t_{PHL}$  are the same as  $t_{pd}$ .

**Figure 5. Load Circuit and Voltage Waveforms**



PACKAGING INFORMATION

Orderable Device	Status (1)	Package Type	Package Drawing	Pins	Package Qty	Eco Plan (2)	Lead/Ball Finish	MSL Peak Temp (3)	Op Temp (°C)	Top-Side Markings (4)	Samples
SN74AUP1T32DCKR	ACTIVE	SC70	DCK	5	3000	Green (RoHS & no Sb/Br)	CU NIPDAU	Level-1-260C-UNLIM	-40 to 85	(6G5 - 6GF)	

(1) The marketing status values are defined as follows:

**ACTIVE:** Product device recommended for new designs.

**LIFEBUY:** TI has announced that the device will be discontinued, and a lifetime-buy period is in effect.

**NRND:** Not recommended for new designs. Device is in production to support existing customers, but TI does not recommend using this part in a new design.

**PREVIEW:** Device has been announced but is not in production. Samples may or may not be available.

**OBSELETE:** TI has discontinued the production of the device.

(2) Eco Plan - The planned eco-friendly classification: Pb-Free (RoHS), Pb-Free (RoHS Exempt), or Green (RoHS & no Sb/Br) - please check <http://www.ti.com/productcontent> for the latest availability information and additional product content details.

**TBD:** The Pb-Free/Green conversion plan has not been defined.

**Pb-Free (RoHS):** TI's terms "Lead-Free" or "Pb-Free" mean semiconductor products that are compatible with the current RoHS requirements for all 6 substances, including the requirement that lead not exceed 0.1% by weight in homogeneous materials. Where designed to be soldered at high temperatures, TI Pb-Free products are suitable for use in specified lead-free processes.

**Pb-Free (RoHS Exempt):** This component has a RoHS exemption for either 1) lead-based flip-chip solder bumps used between the die and package, or 2) lead-based die adhesive used between the die and leadframe. The component is otherwise considered Pb-Free (RoHS compatible) as defined above.

**Green (RoHS & no Sb/Br):** TI defines "Green" to mean Pb-Free (RoHS compatible), and free of Bromine (Br) and Antimony (Sb) based flame retardants (Br or Sb do not exceed 0.1% by weight in homogeneous material)

(3) MSL, Peak Temp. -- The Moisture Sensitivity Level rating according to the JEDEC industry standard classifications, and peak solder temperature.

(4) Multiple Top-Side Markings will be inside parentheses. Only one Top-Side Marking contained in parentheses and separated by a "-" will appear on a device. If a line is indented then it is a continuation of the previous line and the two combined represent the entire Top-Side Marking for that device.

**Important Information and Disclaimer:** The information provided on this page represents TI's knowledge and belief as of the date that it is provided. TI bases its knowledge and belief on information provided by third parties, and makes no representation or warranty as to the accuracy of such information. Efforts are underway to better integrate information from third parties. TI has taken and continues to take reasonable steps to provide representative and accurate information but may not have conducted destructive testing or chemical analysis on incoming materials and chemicals. TI and TI suppliers consider certain information to be proprietary, and thus CAS numbers and other limited information may not be available for release.

In no event shall TI's liability arising out of such information exceed the total purchase price of the TI part(s) at issue in this document sold by TI to Customer on an annual basis.

**TAPE AND REEL INFORMATION**

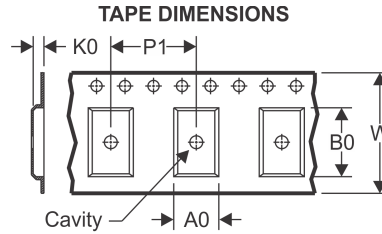
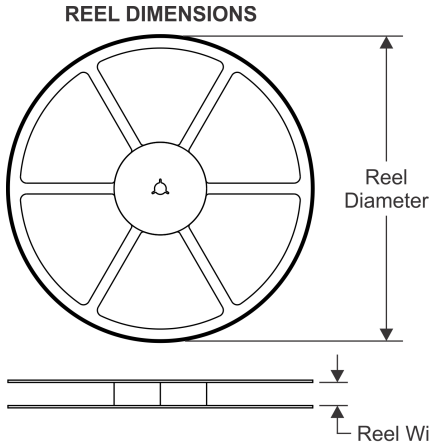

A0	Dimension designed to accommodate the component width
B0	Dimension designed to accommodate the component length
K0	Dimension designed to accommodate the component thickness
W	Overall width of the carrier tape
P1	Pitch between successive cavity centers

**QUADRANT ASSIGNMENTS FOR PIN 1 ORIENTATION IN TAPE**

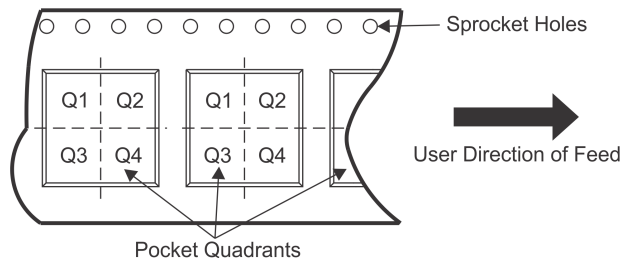

\*All dimensions are nominal

Device	Package Type	Package Drawing	Pins	SPQ	Reel Diameter (mm)	Reel Width W1 (mm)	A0 (mm)	B0 (mm)	K0 (mm)	P1 (mm)	W (mm)	Pin1 Quadrant
SN74AUP1T32DCKR	SC70	DCK	5	3000	178.0	9.0	2.4	2.5	1.2	4.0	8.0	Q3
SN74AUP1T32DCKR	SC70	DCK	5	3000	178.0	9.2	2.4	2.4	1.22	4.0	8.0	Q3

**TAPE AND REEL BOX DIMENSIONS**

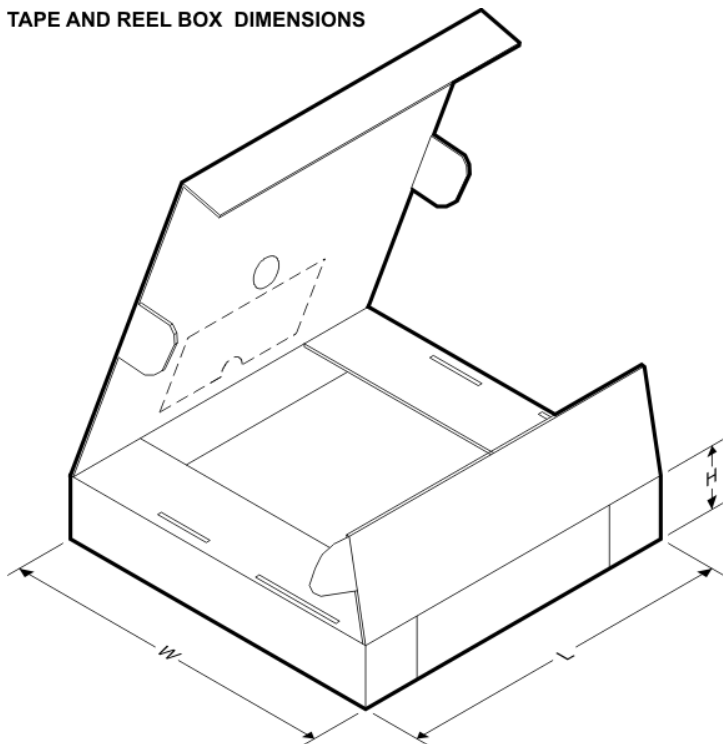

\*All dimensions are nominal

Device	Package Type	Package Drawing	Pins	SPQ	Length (mm)	Width (mm)	Height (mm)
SN74AUP1T32DCKR	SC70	DCK	5	3000	180.0	180.0	18.0
SN74AUP1T32DCKR	SC70	DCK	5	3000	180.0	180.0	18.0

**MECHANICAL DATA**

**DCK (R-PDSO-G5)**

**PLASTIC SMALL-OUTLINE PACKAGE**

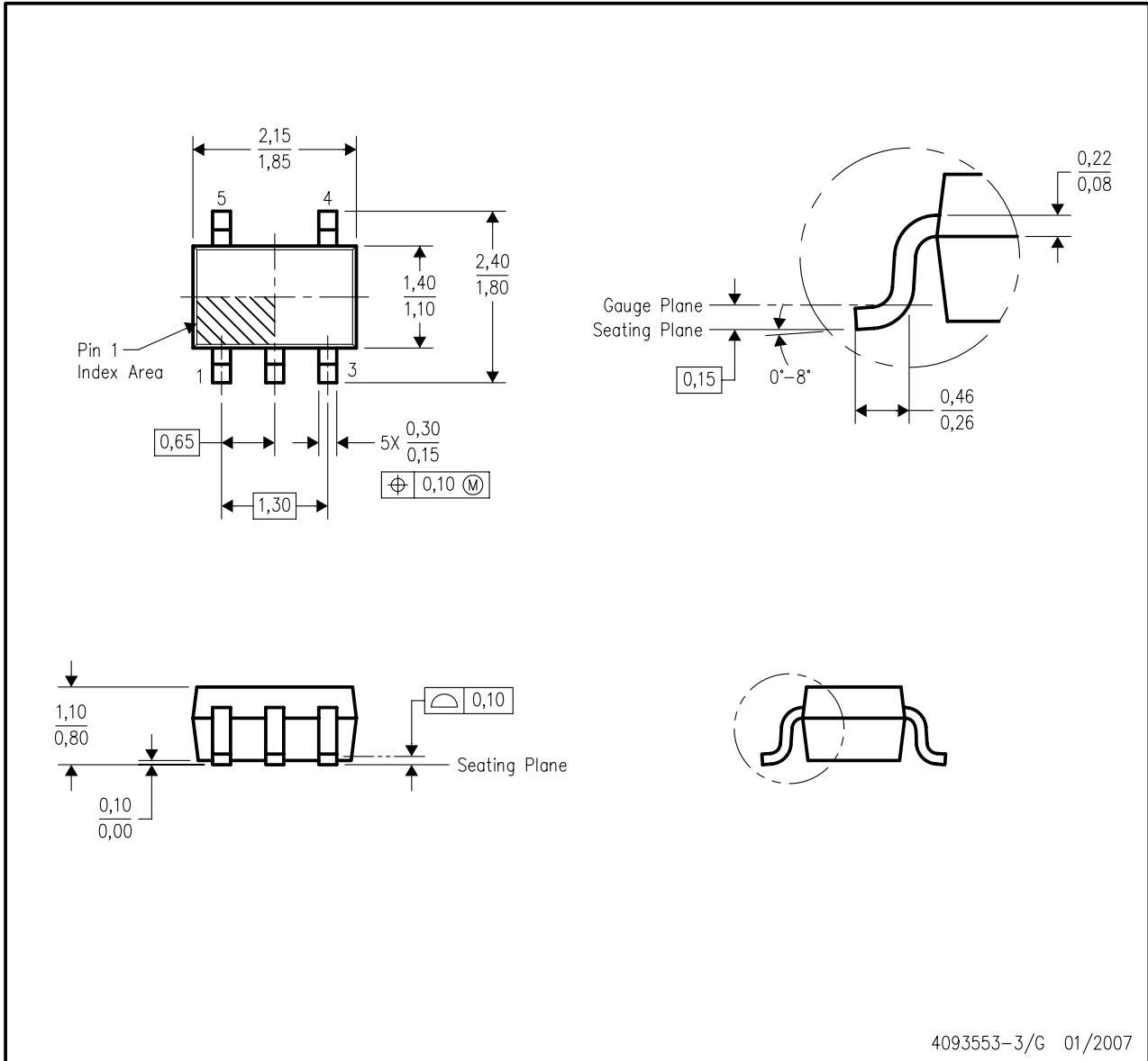

- NOTES:
- A. All linear dimensions are in millimeters.
  - B. This drawing is subject to change without notice.
  - C. Body dimensions do not include mold flash or protrusion. Mold flash and protrusion shall not exceed 0.15 per side.
  - D. Falls within JEDEC MO-203 variation AA.

**LAND PATTERN DATA**

DCK (R-PDSO-G5)

PLASTIC SMALL OUTLINE

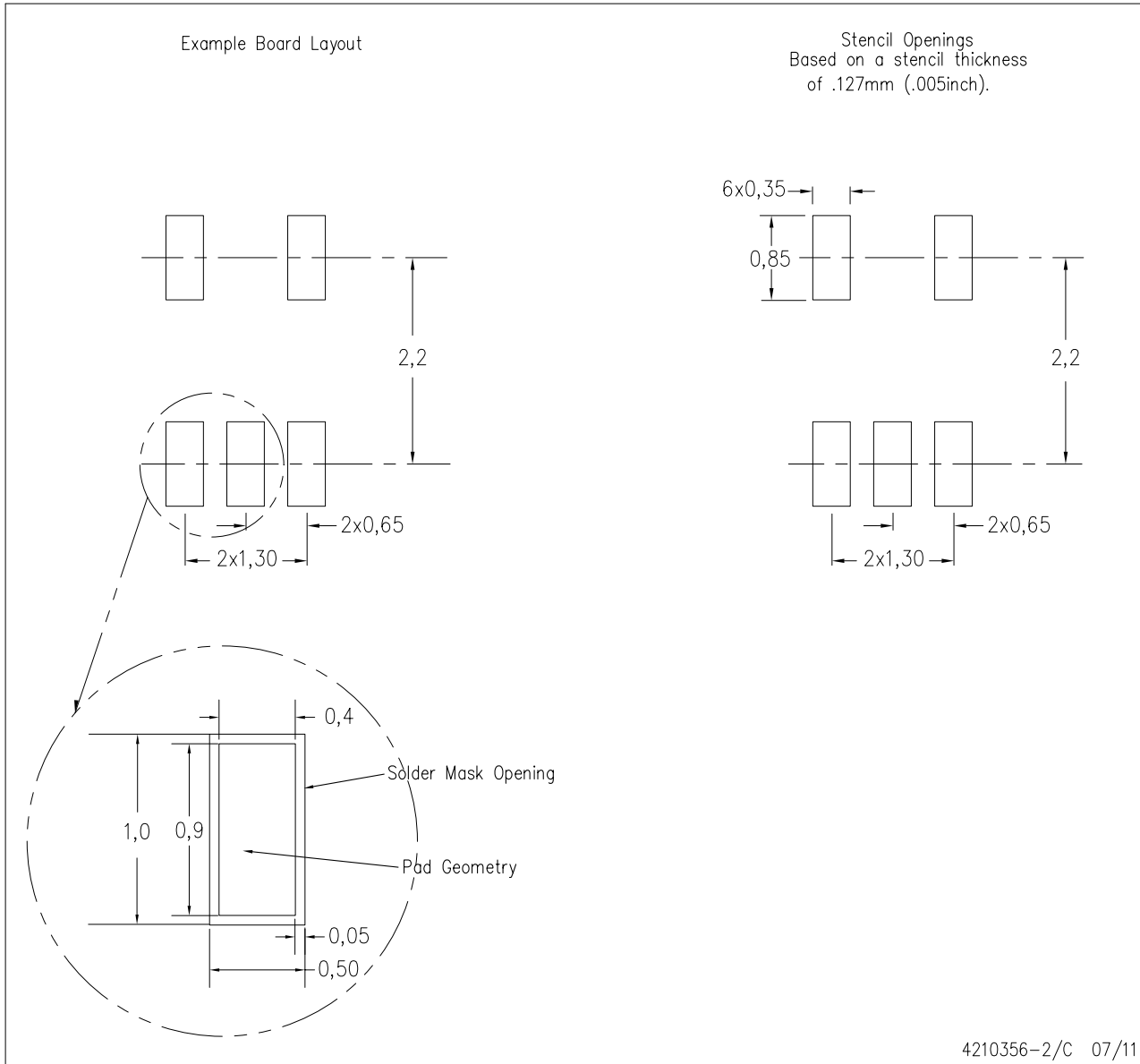

- NOTES:
- A. All linear dimensions are in millimeters.
  - B. This drawing is subject to change without notice.
  - C. Customers should place a note on the circuit board fabrication drawing not to alter the center solder mask defined pad.
  - D. Publication IPC-7351 is recommended for alternate designs.
  - E. Laser cutting apertures with trapezoidal walls and also rounding corners will offer better paste release. Customers should contact their board assembly site for stencil design recommendations. Example stencil design based on a 50% volumetric metal load solder paste. Refer to IPC-7525 for other stencil recommendations.

## IMPORTANT NOTICE

Texas Instruments Incorporated and its subsidiaries (TI) reserve the right to make corrections, enhancements, improvements and other changes to its semiconductor products and services per JESD46, latest issue, and to discontinue any product or service per JESD48, latest issue. Buyers should obtain the latest relevant information before placing orders and should verify that such information is current and complete. All semiconductor products (also referred to herein as “components”) are sold subject to TI’s terms and conditions of sale supplied at the time of order acknowledgment.

TI warrants performance of its components to the specifications applicable at the time of sale, in accordance with the warranty in TI’s terms and conditions of sale of semiconductor products. Testing and other quality control techniques are used to the extent TI deems necessary to support this warranty. Except where mandated by applicable law, testing of all parameters of each component is not necessarily performed.

TI assumes no liability for applications assistance or the design of Buyers’ products. Buyers are responsible for their products and applications using TI components. To minimize the risks associated with Buyers’ products and applications, Buyers should provide adequate design and operating safeguards.

TI does not warrant or represent that any license, either express or implied, is granted under any patent right, copyright, mask work right, or other intellectual property right relating to any combination, machine, or process in which TI components or services are used. Information published by TI regarding third-party products or services does not constitute a license to use such products or services or a warranty or endorsement thereof. Use of such information may require a license from a third party under the patents or other intellectual property of the third party, or a license from TI under the patents or other intellectual property of TI.

Reproduction of significant portions of TI information in TI data books or data sheets is permissible only if reproduction is without alteration and is accompanied by all associated warranties, conditions, limitations, and notices. TI is not responsible or liable for such altered documentation. Information of third parties may be subject to additional restrictions.

Resale of TI components or services with statements different from or beyond the parameters stated by TI for that component or service voids all express and any implied warranties for the associated TI component or service and is an unfair and deceptive business practice. TI is not responsible or liable for any such statements.

Buyer acknowledges and agrees that it is solely responsible for compliance with all legal, regulatory and safety-related requirements concerning its products, and any use of TI components in its applications, notwithstanding any applications-related information or support that may be provided by TI. Buyer represents and agrees that it has all the necessary expertise to create and implement safeguards which anticipate dangerous consequences of failures, monitor failures and their consequences, lessen the likelihood of failures that might cause harm and take appropriate remedial actions. Buyer will fully indemnify TI and its representatives against any damages arising out of the use of any TI components in safety-critical applications.

In some cases, TI components may be promoted specifically to facilitate safety-related applications. With such components, TI’s goal is to help enable customers to design and create their own end-product solutions that meet applicable functional safety standards and requirements. Nonetheless, such components are subject to these terms.

No TI components are authorized for use in FDA Class III (or similar life-critical medical equipment) unless authorized officers of the parties have executed a special agreement specifically governing such use.

Only those TI components which TI has specifically designated as military grade or “enhanced plastic” are designed and intended for use in military/aerospace applications or environments. Buyer acknowledges and agrees that any military or aerospace use of TI components which have **not** been so designated is solely at the Buyer’s risk, and that Buyer is solely responsible for compliance with all legal and regulatory requirements in connection with such use.

TI has specifically designated certain components as meeting ISO/TS16949 requirements, mainly for automotive use. In any case of use of non-designated products, TI will not be responsible for any failure to meet ISO/TS16949.

### Products

Audio	<a href="http://www.ti.com/audio">www.ti.com/audio</a>
Amplifiers	<a href="http://amplifier.ti.com">amplifier.ti.com</a>
Data Converters	<a href="http://dataconverter.ti.com">dataconverter.ti.com</a>
DLP® Products	<a href="http://www.dlp.com">www.dlp.com</a>
DSP	<a href="http://dsp.ti.com">dsp.ti.com</a>
Clocks and Timers	<a href="http://www.ti.com/clocks">www.ti.com/clocks</a>
Interface	<a href="http://interface.ti.com">interface.ti.com</a>
Logic	<a href="http://logic.ti.com">logic.ti.com</a>
Power Mgmt	<a href="http://power.ti.com">power.ti.com</a>
Microcontrollers	<a href="http://microcontroller.ti.com">microcontroller.ti.com</a>
RFID	<a href="http://www.ti-rfid.com">www.ti-rfid.com</a>
OMAP Applications Processors	<a href="http://www.ti.com/omap">www.ti.com/omap</a>
Wireless Connectivity	<a href="http://www.ti.com/wirelessconnectivity">www.ti.com/wirelessconnectivity</a>

### Applications

Automotive and Transportation	<a href="http://www.ti.com/automotive">www.ti.com/automotive</a>
Communications and Telecom	<a href="http://www.ti.com/communications">www.ti.com/communications</a>
Computers and Peripherals	<a href="http://www.ti.com/computers">www.ti.com/computers</a>
Consumer Electronics	<a href="http://www.ti.com/consumer-apps">www.ti.com/consumer-apps</a>
Energy and Lighting	<a href="http://www.ti.com/energy">www.ti.com/energy</a>
Industrial	<a href="http://www.ti.com/industrial">www.ti.com/industrial</a>
Medical	<a href="http://www.ti.com/medical">www.ti.com/medical</a>
Security	<a href="http://www.ti.com/security">www.ti.com/security</a>
Space, Avionics and Defense	<a href="http://www.ti.com/space-avionics-defense">www.ti.com/space-avionics-defense</a>
Video and Imaging	<a href="http://www.ti.com/video">www.ti.com/video</a>

### TI E2E Community

[e2e.ti.com](http://e2e.ti.com)