

Excellent Integrated System Limited

Stocking Distributor

Click to view price, real time Inventory, Delivery & Lifecycle Information:

[Vishay/Siliconix](#)
[DG3516DB-T5-E1](#)

For any questions, you can email us directly:
sales@integrated-circuit.com



DG3516, DG3517

Vishay Siliconix

300 MHz, 2.5 Ω, Dual SPDT Analog Switches

DESCRIPTION

The DG3516, DG3517 are dual SPDT analog switches which operate from 1.8 V to 5.5 V single rail power supply. They are design for audio, video, and USB switching applications.

The devices have 2.5 Ω on-resistance and 300 MHz 3dB bandwidth. 0.2 Ω on-resistance matching and 1 Ω flatness make the device high linearity. The devices are 1.6 V logic compatible within the full operation voltage range.

These switches are built on a sub-micron high density process that brings low power consumption and low voltage performance.

The switches are packaged in MICRO FOOT chip scale package of 4 mm x 3 mm bump array.

As a committed partner to the community and environment, Vishay Siliconix manufactures this product with the lead (Pb)-free device terminations. For MICRO FOOT analog switch products manufactured with tin/silver/copper (SnAgCu) device termination, the lead (Pb)-free “-E1” suffix is being used as a designator.

FEATURES

- Halogen-free according to IEC 61249-2-21 Definition
- 1.8 V to 5.5 V operation
- 2.5 Ω at 2.7 V R_{ON}
- 300 MHz - 3 dB bandwidth
- ESD method 3015.7 > 2 kV
- Latch-up current 200 mA (JESD 78)
- 1.6 V logic compatible
- Compliant to RoHS Directive 2002/95/EC



RoHS
COMPLIANT
HALOGEN
FREE

BENEFITS

- Space Saving MICRO FOOT® Package
- High Linearity
- Low Power Consumption
- High Bandwidth
- Full Rail Signal Swing Range

APPLICATIONS

- Cellular Phones
- MP3
- Media Players
- Modems
- Hard Drives
- PCMCIA

FUNCTIONAL BLOCK DIAGRAM AND PIN CONFIGURATION

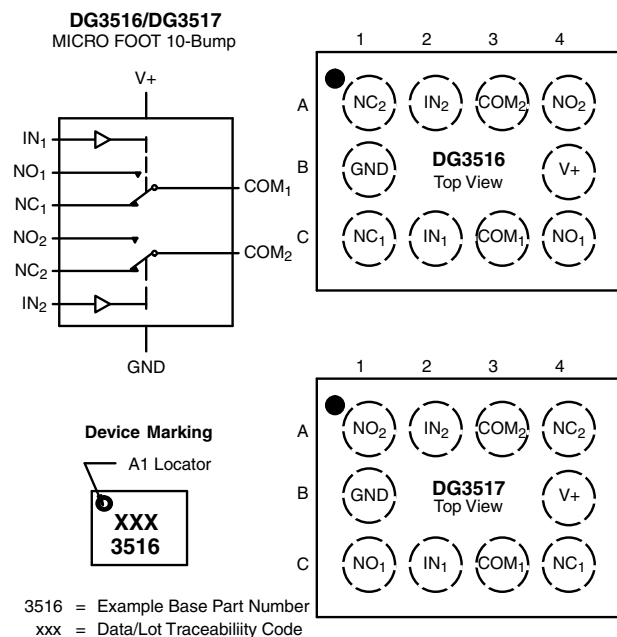

TRUTH TABLE		
Logic	NC1 and NC2	NO1 and NO2
0	ON	OFF
1	OFF	ON

ORDERING INFORMATION		
Temp. Range	Package	Part Number
- 40 °C to 85 °C	MICRO FOOT: 10 Bump (4 x 3, 0.5 mm Pitch, 238 μm Bump Height)	DG3516DB-T5-E1 DG3517DB-T5-E1

Product is End of Life

DG3516, DG3517

Vishay Siliconix



ABSOLUTE MAXIMUM RATINGS			
Parameter		Limit	Unit
Reference V+ to GND		- 0.3 to + 6	V
IN, COM, NC, NO ^a		- 0.3 to (V+ + 0.3)	
Continuous Current (NO, NC, COM)		± 100	mA
Peak Current (Pulsed at 1 ms, 10 % duty cycle)		± 200	
Storage Temperature	(D Suffix)	- 65 to 150	°C
Package Solder Reflow Conditions ^b	IR/Convection	250	
ESD per Method 3015.7		> 2	kV
Power Dissipation (Packages) ^c	MICRO FOOT: 10 Bump (4 mm x 3 mm) ^d	457	mW

Notes:

- a. Signals on NC, NO, or COM or IN exceeding V+ will be clamped by internal diodes. Limit forward diode current to maximum current ratings.
- b. Refer to IPC/JEDEC (J-STD-020B).
- c. All bumps welded or soldered to PC board.
- d. Derate 5.7 mW/°C above 70 °C.

Stresses beyond those listed under "Absolute Maximum Ratings" may cause permanent damage to the device. These are stress ratings only, and functional operation of the device at these or any other conditions beyond those indicated in the operational sections of the specifications is not implied. Exposure to absolute maximum rating conditions for extended periods may affect device reliability.

SPECIFICATIONS (V+ = 3 V)							
Parameter	Symbol	Test Conditions Otherwise Unless Specified V+ = 2.7 V to 3.6 V, V _{IN} = 0.5 V or 1.4 V ^e	Temp. ^a	Limits - 40 °C to 85 °C			Unit
				Min. ^b	Typ. ^c	Max. ^b	
Analog Switch							
Analog Signal Range ^d	V _{NO} , V _{NC} , V _{COM}		Full	0		V+	V
On-Resistance ^d	R _{ON}	V+ = 2.7 V I _{NO} , I _{NC} = 10 mA	Room Full		2.5	3.5 3.8	Ω
R _{ON} Flatness ^d	R _{ON} Flatness		Room		0.52	1	
On-Resistance Match Between Channels ^d	ΔR _{DS(on)}		Room			0.25	
Switch Off Leakage Current	I _{NO(off)} I _{NC(off)}	V+ = 3.3 V, V _{NO} , V _{NC} = 0.3 V/3 V, V _{COM} = 3 V/0.3 V	Room Full	- 2 - 20		2 20	nA
	I _{COM(off)}		Room Full	- 2 - 20		2 20	
Channel-On Leakage Current	I _{COM(on)}	V+ = 3.3 V, V _{NO} , V _{NC} = V _{COM} = 0.3 V/3 V	Room Full	- 2 - 20		2 20	
Digital Control							
Input High Voltage ^d	V _{INH}		Full	1.4			V
Input Low Voltage	V _{INL}		Full			0.5	
Input Capacitance	C _{in}		Full		5		pF
Input Current	I _{INL} or I _{INH}	V _{IN} = 0 V or V+	Full	1		1	μA

Product is End of Life



DG3516, DG3517
 Vishay Siliconix

SPECIFICATIONS (V+ = 3 V)							
Parameter	Symbol	Test Conditions Otherwise Unless Specified V+ = 2.7 V to 3.6 V, V _{IN} = 0.5 V or 1.4 V ^e	Temp. ^a	Limits - 40 °C to 85 °C			Unit
				Min. ^b	Typ. ^c	Max. ^b	
Dynamic Characteristics							
Turn-On Time	t _{ON}	V+ = 2.7 V, V _{NO} or V _{NC} = 1.5 V R _L = 300 Ω, C _L = 35 pF	Room Full		21	51	ns
Turn-Off Time	t _{OFF}		Room Full		15	45	
Break-Before-Make Time	t _d		Full	1		46	
Charge Injection ^d	Q _{INJ}	C _L = 1 nF, V _{GEN} = 2 V, R _{GEN} = 0 Ω	Room		1		pC
Off-Isolation ^d	OIRR	R _L = 50 Ω, C _L = 5 pF	f = 1 MHz	Room	- 74		dB
Crosstalk ^d	X _{TALK}		f = 10 MHz	Room	- 54		
			f = 1 MHz	Room	- 76		
			f = 10 MHz	Room	- 56		
N _O , N _C Off Capacitance ^d	C _{NO(off)}	V _{IN} = 0 or V+, f = 1 MHz	Room		12		pF
	C _{NC(off)}		Room		12		
Channel-On Capacitance ^d	C _{NO(on)}		Room		40		
	C _{NC(on)}		Room		40		
Power Supply							
Power Supply Current	I+	V _{IN} = 0 V or V+	Room Full			1 1	μA

Product is End of Life

DG3516, DG3517

Vishay Siliconix



SPECIFICATIONS (V+ = 5 V)								
Parameter	Symbol	Test Conditions Otherwise Unless Specified		Temp. ^a	Limits - 40 °C to 85 °C			Unit
		V+ = 4.2 V to 5.5 V, V _{IN} = 0.8 V or 2 V ^e			Min. ^b	Typ. ^c	Max. ^b	
Analog Switch								
Analog Signal Range ^d	V _{NO} , V _{NC} , V _{COM}			Full	0		V+	V
On-Resistance ^d	R _{ON}	V+ = 4.2 V I _{NO} , I _{NC} = 10 mA	V _{COM} = 3.5 V	Room Full		2.2	2.9 3.1	Ω
R _{ON} Flatness ^d	R _{ON} Flatness		V _{COM} = 1, 2, 3.5 V	Room		0.53	1	
On-Resistance Match Between Channels ^d	ΔR _{DS(on)}		V _{COM} = 3.5 V	Room			0.25	
Switch Off Leakage Current	I _{NO(off)} I _{NC(off)}	V+ = 5.5 V, V _{NO} , V _{NC} = 1 V/4.5 V, V _{COM} = 4.5 V/1 V		Room Full	- 2 - 20		2 20	nA
	I _{COM(off)}			Room Full	- 2 - 20		2 20	
Channel-On Leakage Current	I _{COM(on)}	V+ = 5.5 V, V _{NO} , V _{NC} = V _{COM} = 1 V/4.5 V		Room Full	- 2 - 20		2 20	
Digital Control								
Input High Voltage ^d	V _{INH}			Full	2			V
Input Low Voltage	V _{INL}			Full			0.8	
Input Capacitance	C _{in}			Full		5		pF
Input Current	I _{INL} or I _{INH}	V _{IN} = 0 or V+		Full	1		1	μA
Dynamic Characteristics								
Turn-On Time	t _{ON}	V+ = 4.2 V, V _{NO} or V _{NC} = 3 V R _L = 300 Ω, C _L = 35 pF		Room Full		15	45 46	ns
Turn-Off Time	t _{OFF}			Room Full		12	42 43	
Break-Before-Make Time	t _d			Full	1			
Charge Injection ^d	Q _{INJ}	C _L = 1 nF, V _{GEN} = 2 V, R _{GEN} = 0 Ω		Room		1		pC
Off-Isolation ^d	OIRR	R _L = 50 Ω, C _L = 5 pF	f = 1 MHz	Room		- 74		dB
			f = 10 MHz	Room		- 54		
Crosstalk ^d	X _{TALK}		f = 1 MHz	Room		- 78		
			f = 10 MHz	Room		- 56		
N _O , N _C Off Capacitance ^d	C _{NO(off)}	V _{IN} = 0 or V+, f = 1 MHz		Room		12		pF
	C _{NC(off)}			Room		12		
Channel-On Capacitance ^d	C _{NO(on)}			Room		40		
	C _{NC(on)}			Room		40		
Power Supply								
Power Supply Current	I+	V _{IN} = 0 V or V+		Room Full			1 1	μA

Notes:

- Room = 25 °C, Full = as determined by the operating suffix.
- Typical values are for design aid only, not guaranteed nor subject to production testing.
- The algebraic convention whereby the most negative value is a minimum and the most positive a maximum, is used in this datasheet.
- Guarantee by design, nor subjected to production test.
- V_{IN} = input voltage to perform proper function.
- Guaranteed by 5 V testing, not production tested.

Product is End of Life



DG3516, DG3517
Vishay Siliconix

TYPICAL CHARACTERISTICS (25 °C, unless otherwise noted)

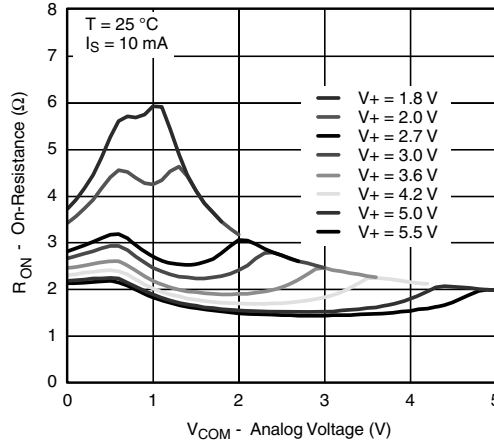

RON vs. VCOM and Single Supply Voltage

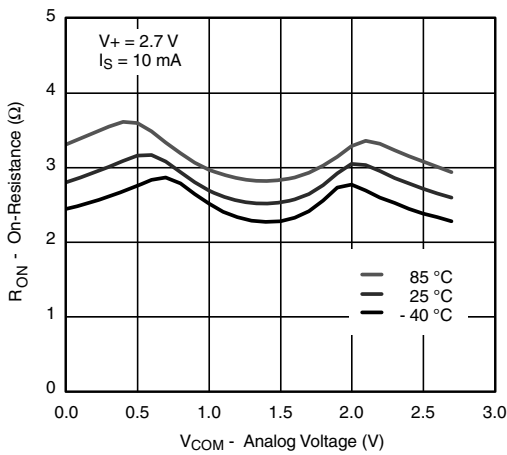

RON vs. Analog Voltage and Temperature

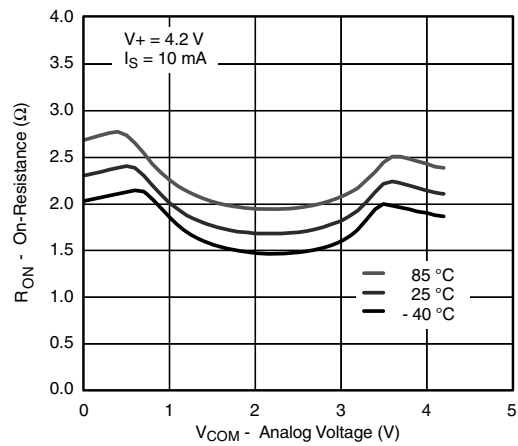

RON vs. Analog Voltage and Temperature

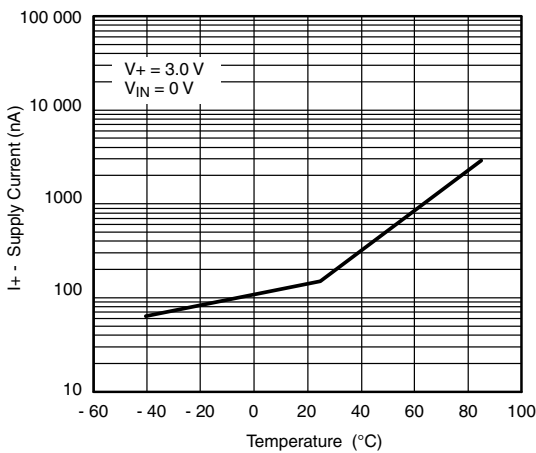

Supply Current vs. Temperature

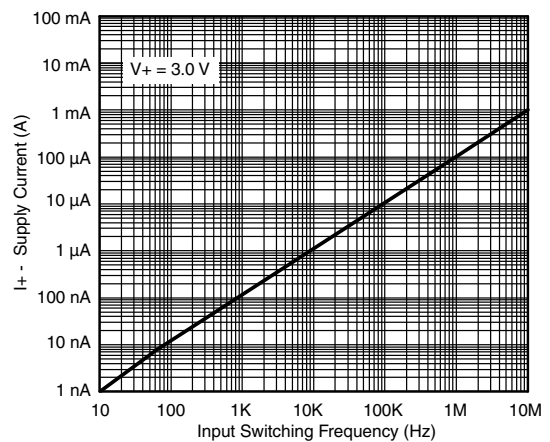

Supply Current vs. Input Switching Frequency

Product is End of Life

DG3516, DG3517

Vishay Siliconix



TYPICAL CHARACTERISTICS (25 °C, unless otherwise noted)

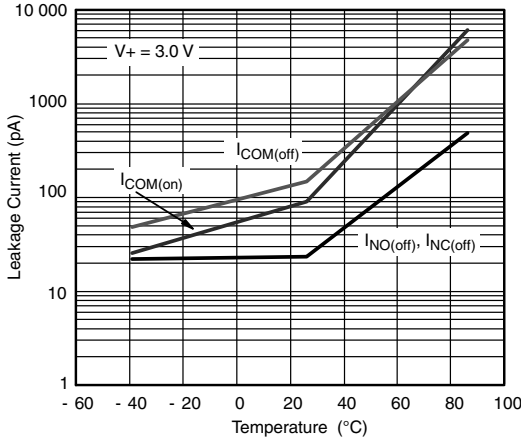

Leakage Current vs. Temperature

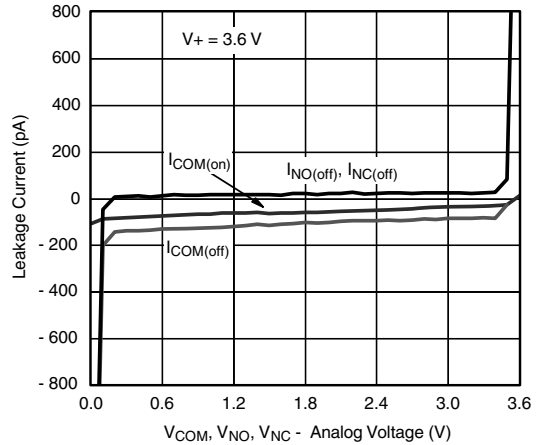

Leakage vs. Analog Voltage

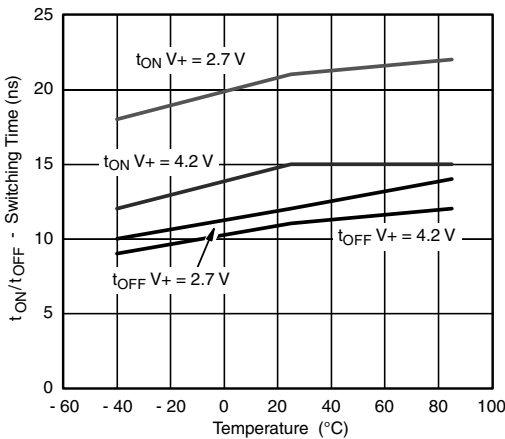

Switching Time vs. Temperature

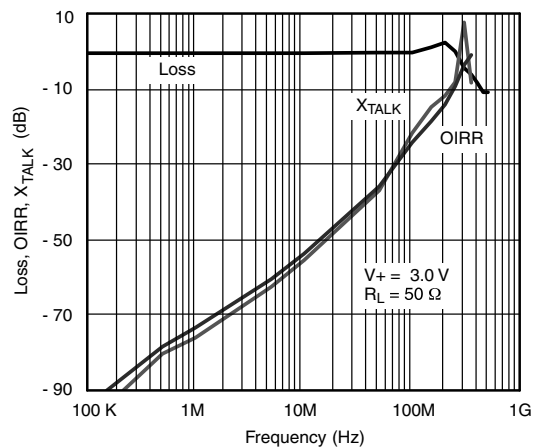

Insertion Loss, Off-Isolation Crosstalk vs. Frequency

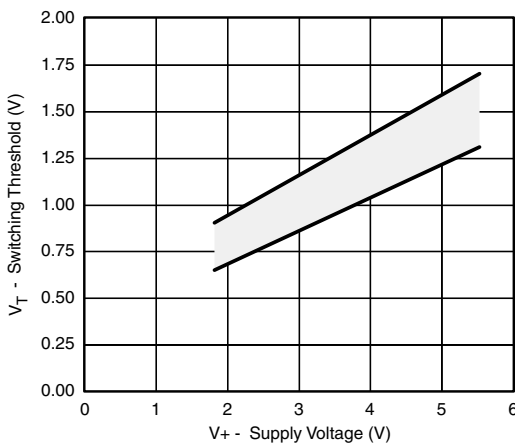

Switching Threshold vs. Supply Voltage

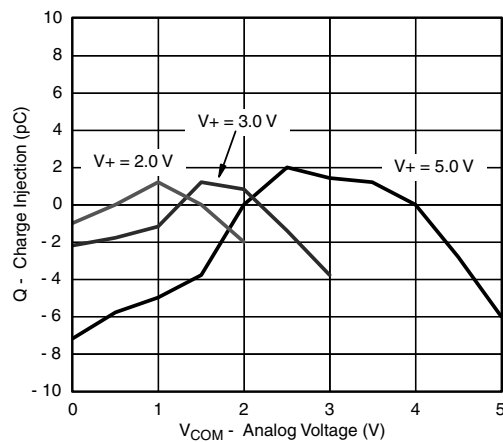

Charge Injection vs. Analog Voltage

Product is End of Life



DG3516, DG3517
Vishay Siliconix

TEST CIRCUITS

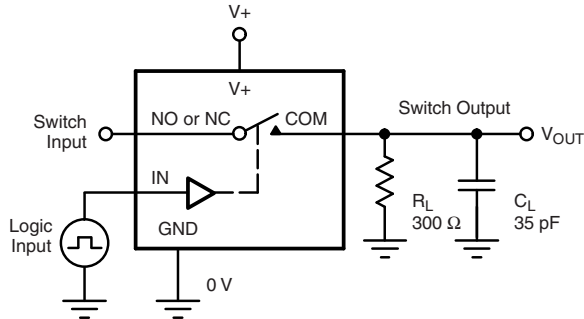

C_L (includes fixture and stray capacitance)

$$V_{OUT} = V_{COM} \left(\frac{R_L}{R_L + R_{ON}} \right)$$

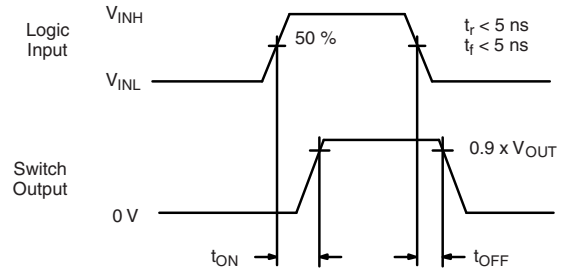

Logic "1" = Switch On
 Logic input waveforms inverted for switches that have the opposite logic sense.

Figure 1. Switching Time

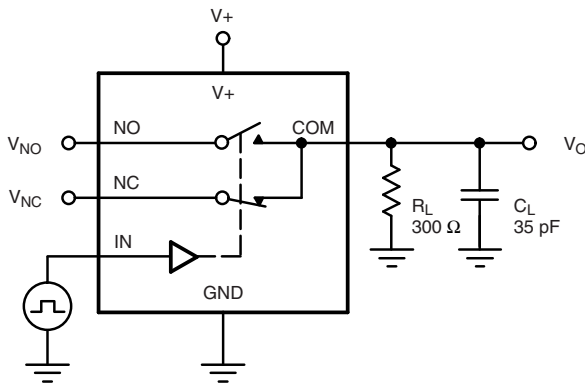

C_L (includes fixture and stray capacitance)

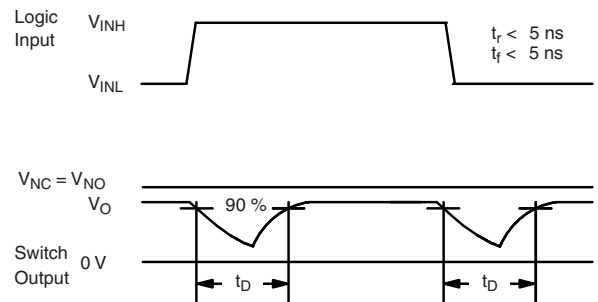
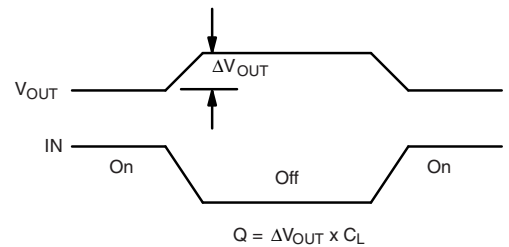
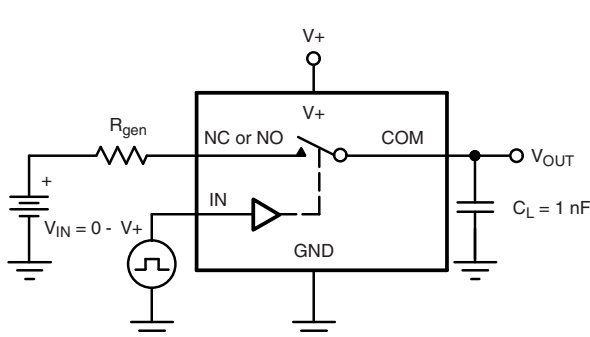

Figure 2. Break-Before-Make Interval



IN depends on switch configuration: input polarity determined by sense of switch.

Figure 3. Charge Injection

DG3516, DG3517

Vishay Siliconix



TEST CIRCUITS

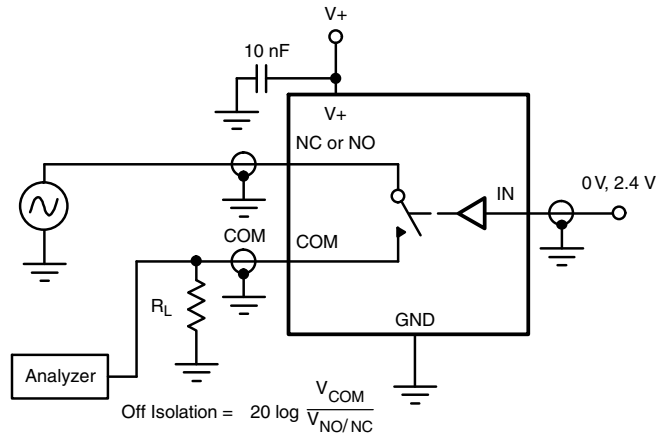

Figure 4. Off-Isolation

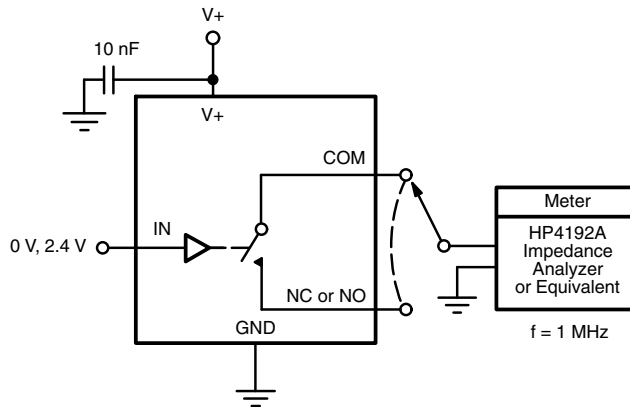

Figure 5. Channel Off/On Capacitance

Product is End of Life



DG3516, DG3517
Vishay Siliconix

PACKAGE OUTLINE

MICRO FOOT: 10 BUMP (4 x 3 0.5 mm PITCH, 0.238 mm BUMP HEIGHT)

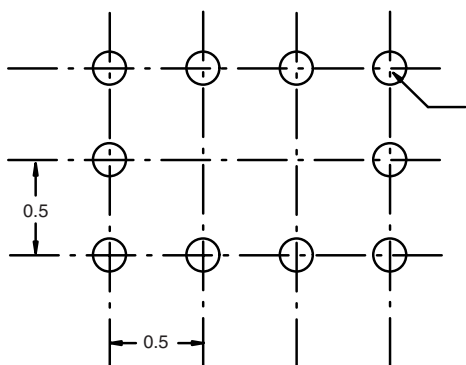

Recommended Land Pattern

10 x \varnothing 0.150 ~ 0.229
 Note b
 Solder Mask \varnothing ~ Pad Diameter + 0.1

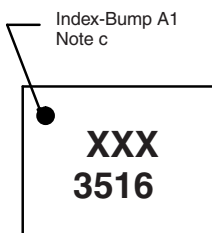
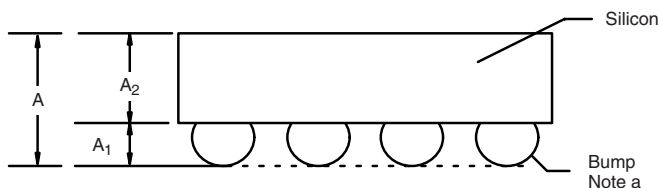

Top Side (Die Back)

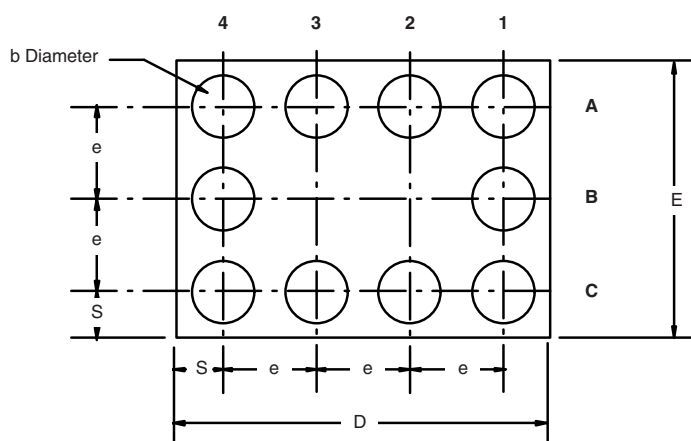

Notes (Unless Otherwise Specified):

- a. Bump is Lead (Pb)-free Sn/Ag/Cu.
- b. Non-solder mask defined copper landing pad.
- c. Laser Mark on silicon die back; back-lapped, no coating. Shown is not actual marking; sample only.

Dim.	Millimeters ^a		Inches	
	Min.	Max.	Min.	Max.
A	0.688	0.753	0.0271	0.0296
A ₁	0.218	0.258	0.0086	0.0102
A ₂	0.470	0.495	0.0185	0.0195
b	0.306	0.346	0.0120	0.0136
D	1.980	2.020	0.0780	0.0795
E	1.480	1.520	0.0583	0.0598
e	0.5 BASIC		0.0197 BASIC	
S	0.230	0.270	0.0091	0.0106

Notes:

- a. Use millimeters as the primary measurement.

Vishay Siliconix maintains worldwide manufacturing capability. Products may be manufactured at one of several qualified locations. Reliability data for Silicon Technology and Package Reliability represent a composite of all qualified locations. For related documents such as package/tape drawings, part marking, and reliability data, see www.vishay.com/ppg?73404.



Package Information

Vishay Siliconix

MICRO FOOT: 10-BUMP (4 mm x 3 mm, 0.5 mm PITCH, 0.238 mm BUMP HEIGHT)

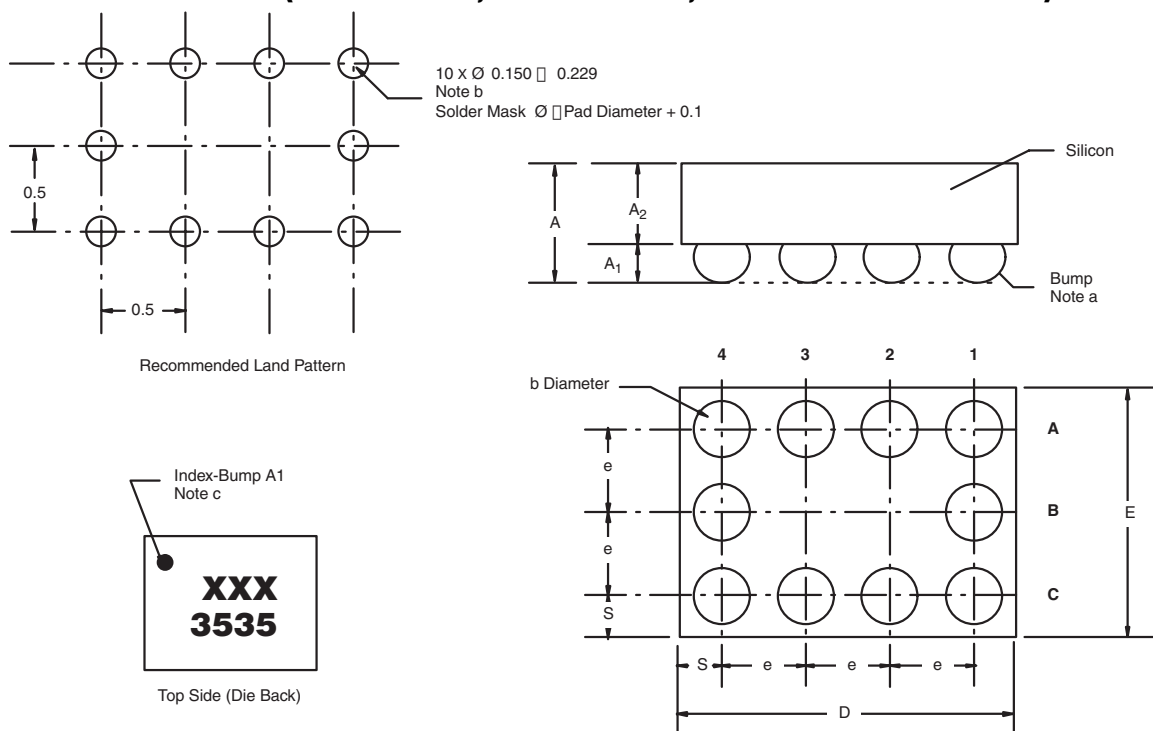

Notes

(unless otherwise specified)

- Bump is lead (Pb)-free Sn/Ag/Cu.
- Non-solder mask defined copper landing pad.
- Laser mark on silicon die back; back-lapped, no coating. Shown is not actual marking; sample only.

DIM.	MILLIMETERS ^a		INCHES	
	MIN.	MAX.	MIN.	MAX.
A	0.688	0.753	0.0271	0.0296
A ₁	0.218	0.258	0.0086	0.0102
A ₂	0.470	0.495	0.0185	0.0195
b	0.306	0.346	0.0120	0.0136
D	1.980	2.020	0.0780	0.0795
E	1.480	1.520	0.0583	0.0598
e	0.5 BASIC		0.0197 BASIC	
S	0.230	0.270	0.0091	0.0106

Note

- Use millimeters as the primary measurement.

ECN: S11-1065-Rev. A, 13-Jun-11
 DWG: 6001



Disclaimer

ALL PRODUCT, PRODUCT SPECIFICATIONS AND DATA ARE SUBJECT TO CHANGE WITHOUT NOTICE TO IMPROVE RELIABILITY, FUNCTION OR DESIGN OR OTHERWISE.

Vishay Intertechnology, Inc., its affiliates, agents, and employees, and all persons acting on its or their behalf (collectively, "Vishay"), disclaim any and all liability for any errors, inaccuracies or incompleteness contained in any datasheet or in any other disclosure relating to any product.

Vishay makes no warranty, representation or guarantee regarding the suitability of the products for any particular purpose or the continuing production of any product. To the maximum extent permitted by applicable law, Vishay disclaims (i) any and all liability arising out of the application or use of any product, (ii) any and all liability, including without limitation special, consequential or incidental damages, and (iii) any and all implied warranties, including warranties of fitness for particular purpose, non-infringement and merchantability.

Statements regarding the suitability of products for certain types of applications are based on Vishay's knowledge of typical requirements that are often placed on Vishay products in generic applications. Such statements are not binding statements about the suitability of products for a particular application. It is the customer's responsibility to validate that a particular product with the properties described in the product specification is suitable for use in a particular application. Parameters provided in datasheets and / or specifications may vary in different applications and performance may vary over time. All operating parameters, including typical parameters, must be validated for each customer application by the customer's technical experts. Product specifications do not expand or otherwise modify Vishay's terms and conditions of purchase, including but not limited to the warranty expressed therein.

Except as expressly indicated in writing, Vishay products are not designed for use in medical, life-saving, or life-sustaining applications or for any other application in which the failure of the Vishay product could result in personal injury or death. Customers using or selling Vishay products not expressly indicated for use in such applications do so at their own risk. Please contact authorized Vishay personnel to obtain written terms and conditions regarding products designed for such applications.

No license, express or implied, by estoppel or otherwise, to any intellectual property rights is granted by this document or by any conduct of Vishay. Product names and markings noted herein may be trademarks of their respective owners.