

Excellent Integrated System Limited

Stocking Distributor

Click to view price, real time Inventory, Delivery & Lifecycle Information:

[Rohm Semiconductor](#)
[DTC114ECAT116](#)

For any questions, you can email us directly:

sales@integrated-circuit.com

Transistors

Digital transistors (built-in resistors)

DTC114EE / DTC114EUA / DTC114EKA

DTC114ECA / DTC114ESA

●Features

- 1) Built-in bias resistors enable the configuration of an inverter circuit without connecting external input resistors (see equivalent circuit).
- 2) The bias resistors consist of thin-film resistors with complete isolation to allow negative biasing of the input. They also have the advantage of almost completely eliminating parasitic effects.
- 3) Only the on/off conditions need to be set for operation, making device design easy.

●Structure

NPN digital transistor
 (with built-in resistors)

●Equivalent circuit

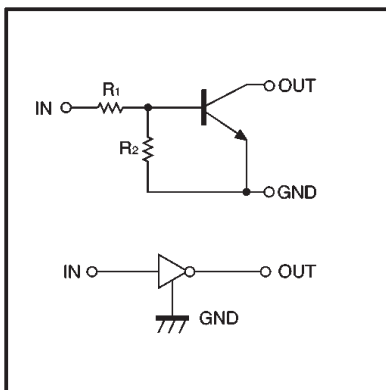

●External dimensions (Units: mm)

<p>DTC114EE</p> <p>ROHM : EMT3</p> <p>Abbreviated symbol : 24</p>		<p>(1) GND (2) IN (3) OUT</p>
<p>DTC114EUA</p> <p>ROHM : UMT3 EIAJ : SC-70</p> <p>All terminals have same dimensions</p> <p>Abbreviated symbol : 24</p>		<p>(1) GND (2) IN (3) OUT</p>
<p>DTC114EKA</p> <p>ROHM : SMT3 EIAJ : SC-59</p> <p>All terminals have same dimensions</p> <p>Abbreviated symbol : 24</p>		<p>(1) GND (2) IN (3) OUT</p>
<p>DTC114ECA</p> <p>ROHM : SST3</p> <p>All terminals have same dimensions</p> <p>Abbreviated symbol : 24</p>		<p>(1) GND (2) IN (3) OUT</p>
<p>DTC114ESA</p> <p>ROHM : SPT EIAJ : SC-72</p>		<p>(1) GND (2) OUT (3) IN</p>

Transistors DTC114EE/DTC114EUA/DTC114EKA/DTC114ECA/DTC114ESA

● Absolute maximum ratings (Ta=25°C)

Parameter	Symbol	Limits(DTC114E□)					Unit
		E	UA	KA	CA	SA	
Supply voltage	V _{CC}	50					V
Input voltage	V _{IN}	-10~+40					V
Output current	I _o	50					mA
	I _{C(Max.)}	100					
Power dissipation	P _d	150	200		300		mW
Junction temperature	T _j	150					°C
Storage temperature	T _{stg}	-55~+150					°C

● Electrical characteristics (Ta=25°C)

Parameter	Symbol	Min.	Typ.	Max.	Unit	Conditions
Input voltage	V _{I(off)}	—	—	0.5	V	V _{CC} =5V, I _o =100 μA
	V _{I(on)}	3	—	—		V _o =0.3V, I _o =10mA
Output voltage	V _{O(on)}	—	0.1	0.3	V	I _o /I _i =10mA/0.5mA
Input current	I _i	—	—	0.88	mA	V _i =5V
Output current	I _{o(off)}	—	—	0.5	μA	V _{CC} =50V, V _i =0V
DC current gain	G _i	30	—	—	—	V _o =5V, I _o =5mA
Input resistance	R ₁	7	10	13	kΩ	—
Resistance ratio	R ₂ /R ₁	0.8	1	1.2	—	—
Transition frequency	f _t	—	250	—	MHz	V _{CE} =10V, I _E =-5mA, f=100MHz *

* Transition frequency of the device

● Packaging specifications

Part No.	Package	EMT3	UMT3	SMT3	SST3	SPT
	Packaging type	Taping	Taping	Taping	Taping	Taping
	Code	TL	T106	T146	T116	TP
	Basic ordering unit (pieces)	3000	3000	3000	3000	5000
DTC114EE		○	—	—	—	—
DTC114EUA		—	○	—	—	—
DTC114EKA		—	—	○	—	—
DTC114ECA		—	—	—	○	—
DTC114ESA		—	—	—	—	○

● Electrical characteristic curves

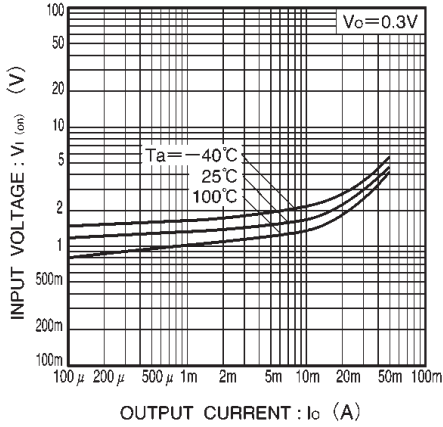

Fig.1 Input voltage vs. output current (ON characteristics)

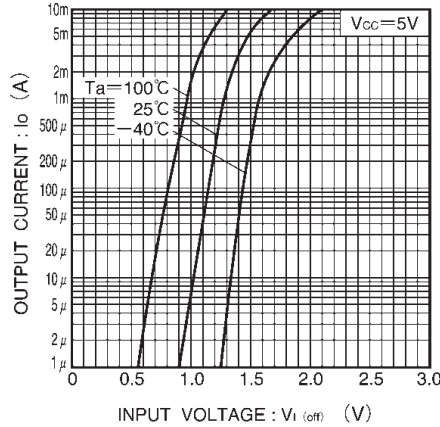

Fig.2 Output current vs. input voltage (OFF characteristics)

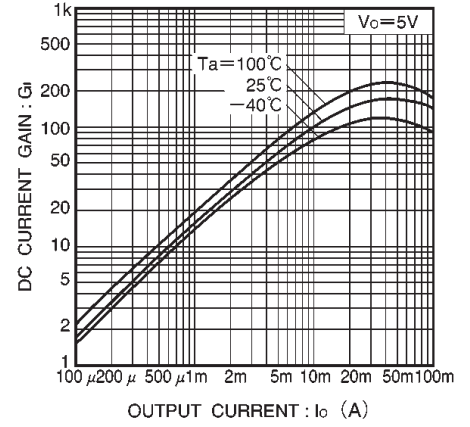

Fig.3 DC current gain vs. output current

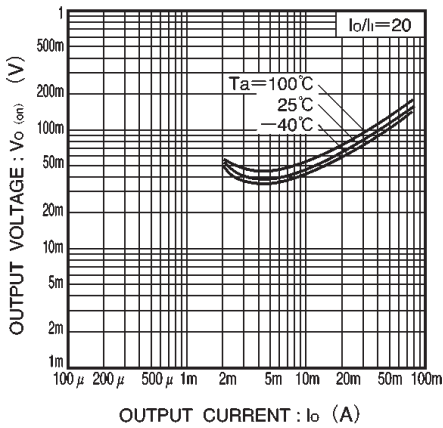

Fig.4 Output voltage vs. output current