

Excellent Integrated System Limited

Stocking Distributor

Click to view price, real time Inventory, Delivery & Lifecycle Information:

[TE Connectivity Aerospace, Defense and Marine
1051988-1](#)

For any questions, you can email us directly:

sales@integrated-circuit.com

SMA Connectors MIL-C-39012 — For Flexible Cable (Continued)

MIL-C-39012/59

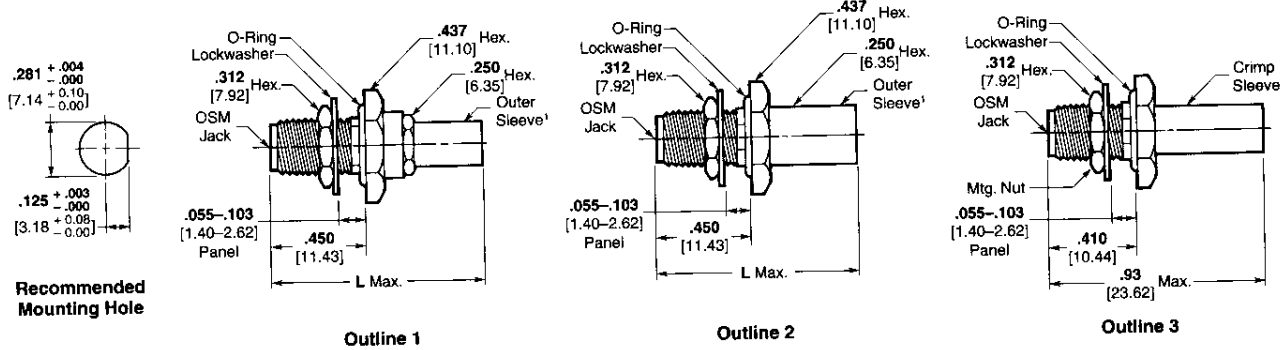

Recommended Mounting Hole

| Military Part No. | AMP Part No. | M/A-COM ¹ Part No. (Ref. Only) | Outline | Cat. ¹ | RG/U Cable | Dim. L |
|-------------------|--------------|---|---------|-------------------|--------------|---------------|
| -3006 | 1051981-1 | 2034-8006-92 | 1 | A | 178 | .960 [24.38] |
| -3007 | 1051982-1 | 2034-8007-92 | 1 | A | 174, 316 | .960 [24.38] |
| -3008 | 1051983-1 | 2034-8008-90 | 2 | A | 122 | .960 [24.38] |
| -3009 | 1051984-1 | 2034-8009-90 | 2 | A | 58, 142, 223 | .960 [24.38] |
| -3010 | 1051985-1 | 2034-8010-90 | 2 | A | 303 | .960 [24.38] |
| B3011 | 1362216-1 | 2034-8011-92 | 1 | B | 178 | 1.265 [32.13] |
| B3012 | 1051986-1 | 2034-8012-92 | 1 | B | 174, 316 | 1.265 [32.13] |
| B3013 | 1083993-1 | 2034-8013-92 | 2 | B | 122 | 1.265 [32.13] |
| B3014 | 1331293-1 | 2034-8014-92 | 2 | B | 58 | 1.265 [32.13] |
| B3015 | 1253627-1 | 2034-8015-92 | 2 | B | 142 | 1.265 [32.13] |
| B3016 | 1221165-1 | 2034-8016-92 | 2 | B | 223 | 1.265 [32.13] |
| B3017 | 1484542-1 | 2034-8017-92 | 2 | B | 303 | 1.265 [32.13] |
| B3018 | 1051987-1 | 2034-8018-92 | 1 | B | 178 | 1.265 [32.13] |
| B3019 | 1051988-1 | 2034-8019-92 | 1 | B | 174, 316 | 1.265 [32.13] |
| B3020 | 1484543-1 | 2034-8020-92 | 2 | B | 122 | 1.265 [32.13] |

| Military Part No. | AMP Part No. | M/A-COM ¹ Part No. (Ref. Only) | Outline | Cat. ¹ | RG/U Cable | Dim. L |
|-------------------|--------------------------|---|---------|-------------------|------------|---------------|
| B3021 | 1087842-1 | 2034-8021-92 | 2 | B | 58 | 1.265 [32.13] |
| B3022 | 1051989-1 | 2034-8022-92 | 2 | B | 142 | 1.265 [32.13] |
| B3023 | 1051990-1 | 2034-8023-92 | 2 | B | 223 | 1.265 [32.13] |
| B3024 | 1051991-1 | 2034-8024-92 | 2 | B | 303 | 1.265 [32.13] |
| -3025 | 1051992-1 | 2034-8025-92 | 1 | C | 178 | 1.125 [28.58] |
| -3026 | 1051994-1 | 2034-8026-92 | 1 | C | 174, 316 | 1.125 [28.58] |
| -3027 | 1051995-1 | 2034-8027-92 | 2 | C | 122 | 1.125 [28.58] |
| -3028 | 1051996-1 | 2034-8028-92 | 2 | C | 142, 223 | 1.125 [28.58] |
| -3029 | 1051997-1 | 2034-8029-92 | 2 | C | 58, 303 | 1.125 [28.58] |
| -3502 | 1051998-1 | 2034-8052-92 | 2 | D | 142, 400 | 1.265 [32.13] |
| -4026 | 1-1532129-3 ² | — | 3 | C | 174, 316 | — |
| -4027 | 1-1532129-4 ³ | — | 3 | C | 122 | — |
| -4028 | 1-1532129-5 ⁴ | — | 3 | C | 142, 223 | — |
| -4029 | 1-1532129-6 ⁵ | — | 3 | C | 58, 303 | — |

¹ Category A: solder sleeve; Categories B, C and D: crimp sleeve.
² Crimp tool M22520/5-01 and M22520/5-35 Closure B. Alternate crimp tool M22520/10-01 and M22520/10-13.
³ Crimp tool M22520/5-01 and M22520/5-41 Closure B. Alternate crimp tool M22520/10-01 and M22520/10-17.
⁴ Crimp tool M22520/5-01 and M22520/5-19 Closure B. Alternate crimp tool M22520/10-01 and M22520/10-21.
⁵ -92 indicates passivated stainless steel finish.
 -90 indicates gold plated finish.
 See page 7003 for description of categories and pages 7059-7064 for tooling (unless noted otherwise).