

Excellent Integrated System Limited

Stocking Distributor

Click to view price, real time Inventory, Delivery & Lifecycle Information:

[Texas Instruments](#)
[TPS386596L33DGKT](#)

For any questions, you can email us directly:

sales@integrated-circuit.com

TPS386596 Quad Reset Supervisor With Manual Reset Input

1 Features

- Four Channel Voltage Detector
- Threshold Accuracy: 0.25% (typ)
- Fixed 50-ms $\overline{\text{RESET}}$ Delay Time
- Active-Low Manual Reset Input
- Very Low Quiescent Current: 7 μA (Typical)
- SVS-1: Fixed Threshold for Monitoring 3.3 V
- SVS-2/3/4: Adjustable Threshold Down to 0.4 V
- Open-Drain $\overline{\text{RESET}}$ Output
- Space-Saving, 8-pin MSOP Package

2 Applications

- Notebook/Desktop Computers
- Industrial Equipment
- Telecom, Networking Infrastructure
- Server, Storage Equipment
- DSP and Microcontroller Applications
- FPGA/ASIC Applications

3 Description

The TPS386596 device monitors four power rails and asserts the $\overline{\text{RESET}}$ signal when any of the SENSE inputs drop below the respective thresholds. SVS-1 can be used to monitor a 3.3-V nominal power supply with no external components required. SVS-2, SVS-3, and SVS-4 are adjustable using external resistors and can be used to monitor any power-supply voltage higher than 0.4 V. All SENSE inputs have a threshold accuracy of 0.25% (typical). The TPS386596L33 also has an active-low manual reset ($\overline{\text{MR}}$) that can assert the $\overline{\text{RESET}}$ signal as desired by the application. The open-drain, active-low $\overline{\text{RESET}}$ output deasserts after a fixed 50-ms delay.

The TPS386596 has a low quiescent current of 7 μA (typical) and is available in a space-saving, 8-pin MSOP package.

Device Information⁽¹⁾

PART NUMBER	PACKAGE	BODY SIZE (NOM)
TPS386596	VSSOP (8)	5.00 mm x 3.00 mm

(1) For all available packages, see the orderable addendum at the end of the data sheet.

TPS386596 Typical Application Circuit

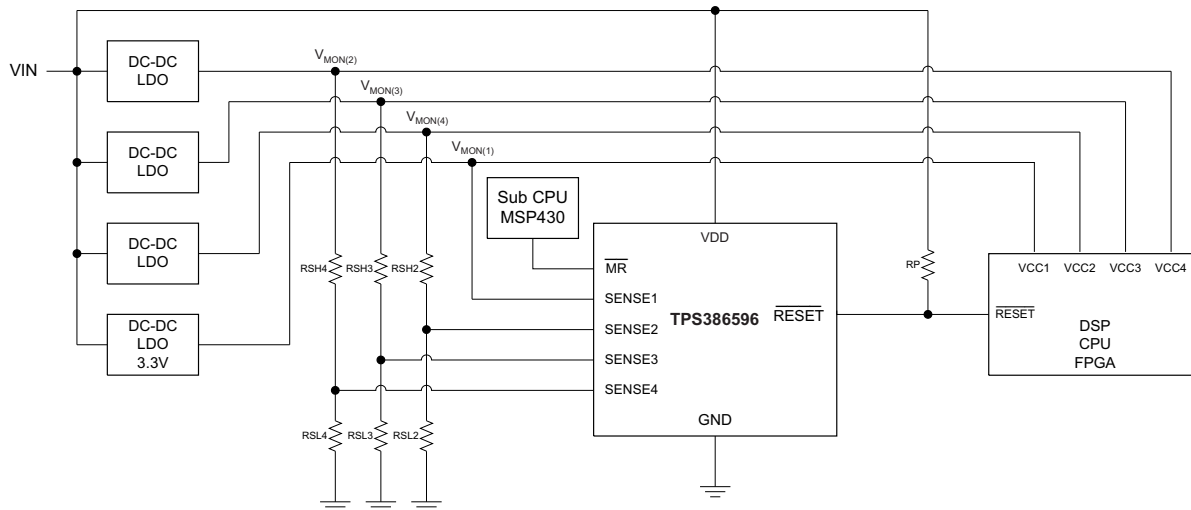

TPS386596

SLVSA75A – JULY 2010 – REVISED AUGUST 2015

www.ti.com

Table of Contents

1 Features	1	8.2 Functional Block Diagram	10
2 Applications	1	8.3 Feature Description	11
3 Description	1	8.4 Device Functional Modes	11
4 Revision History	2	9 Application and Implementation	12
5 Pin Configuration and Functions	3	9.1 Application Information	12
6 Specifications	4	9.2 Typical Application	12
6.1 Absolute Maximum Ratings	4	10 Power Supply Recommendations	15
6.2 ESD Ratings	4	11 Layout	15
6.3 Recommended Operating Conditions	4	11.1 Layout Guidelines	15
6.4 Thermal Information	4	11.2 Layout Example	15
6.5 Electrical Characteristics	5	12 Device and Documentation Support	16
6.6 Timing Requirements	6	12.1 Device Support	16
6.7 Switching Characteristics	6	12.2 Community Resources	16
6.8 Typical Characteristics	7	12.3 Trademarks	16
7 Parameter Measurement Information	9	12.4 Electrostatic Discharge Caution	16
8 Detailed Description	10	12.5 Glossary	16
8.1 Overview	10	13 Mechanical, Packaging, and Orderable Information	16

4 Revision History

Changes from Original (July 2010) to Revision A	Page
• Changed references to <i>TPS386596L33</i> to <i>TPS386596</i> throughout document	1
• Changed <i>Pin Configuration and Functions</i> section; updated table format and pin drawing	3
• Changed "free-air temperature" to "junction temperature" in <i>Absolute Maximum Ratings</i> condition statement	4
• Changed <i>Absolute Maximum Ratings</i> table; moved ESD ratings to separate table	4
• Added <i>ESD Ratings</i> table, <i>Feature Description</i> section, <i>Device Functional Modes</i> , <i>Application and Implementation</i> section, <i>Power Supply Recommendations</i> section, <i>Layout</i> section, <i>Device and Documentation Support</i> section, and <i>Mechanical, Packaging, and Orderable Information</i> section	4
• Changed <i>Thermal Information</i> table; updated thermal resistance values	4
• Changed <i>Electrical Characteristics</i> table; moved timing and switching parameters (t_W , t_D) to separate tables	5
• Changed input voltage range notation from V_{VCC} to V_{DD} throughout <i>Electrical Characteristics</i> table	5
• Changed supply current notation from I_{VCC} to I_{DD} in <i>Electrical Characteristics</i> table	5
• Changed <i>VCC</i> notation in <i>Functional Block Diagram</i> to <i>VDD</i>	10
• Deleted <i>Immunity to SENSE Pin Voltage Transients</i> section; rewrote content and added to <i>Voltage Monitoring</i> section	11
• Changed <i>Sense Inputs</i> section title to <i>Undervoltage Detection</i>	12
• Changed title and graphic for Figure 14	12

5 Pin Configuration and Functions

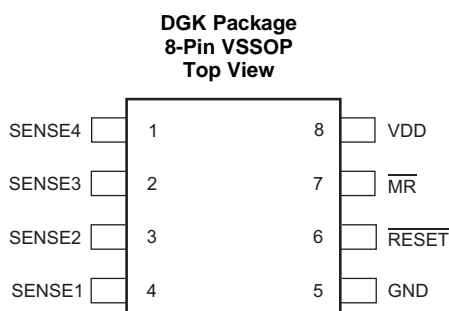

Pin Functions

PIN		I/O	DESCRIPTION	
NAME	NO.			
GND	5	—	Ground	
$\overline{\text{MR}}$	7	I	Manual reset input with internal 100-k Ω pullup to VDD and 50-ns deglitch. Logic low level of this pin asserts $\overline{\text{RESET}}$.	
$\overline{\text{RESET}}$	6	O	$\overline{\text{RESET}}$ is an open-drain output pin. When $\overline{\text{RESET}}$ is asserted, this pin remains in a low-impedance state. When $\overline{\text{RESET}}$ is deasserted, this pin goes to a high-impedance state after 50 ms. A pullup resistor to VDD or another voltage source is required.	
SENSE1	4	I	Monitor voltage input for Supply 1	When the voltage at this terminal drops the threshold voltage (VIT1= 2.9 V), $\overline{\text{RESET}}$ is asserted.
SENSE2	3	I	Monitor voltage input for Supply 2	When the voltage at this terminal drops the threshold voltage (VIT2= 0.4 V), $\overline{\text{RESET}}$ is asserted.
SENSE3	2	I	Monitor voltage input for Supply 3	When the voltage at this terminal drops the threshold voltage (VIT3= 0.4 V), $\overline{\text{RESET}}$ is asserted.
SENSE4	1	I	Monitor voltage input for Supply 4	When the voltage at this terminal drops the threshold voltage (VIT4= 0.4 V), $\overline{\text{RESET}}$ is asserted.
VDD	8	I	Supply voltage. Connecting a 0.1- μF ceramic capacitor close to this pin is recommended.	

TPS386596

SLVSA75A – JULY 2010 – REVISED AUGUST 2015

www.ti.com

6 Specifications

6.1 Absolute Maximum Ratings

over operating junction temperature range (unless otherwise noted).^{(1) (2)}

		MIN	MAX	UNIT
Voltage	Input, V_{DD}	-0.3	7	V
	V_{MR} , V_{SENSE1} , V_{SENSE2} , V_{SENSE3} , V_{SENSE4} , V_{RESET}	-0.3	7	V
Current	RESET pin		5	mA
Power dissipation	Continuous total	See Thermal Information		
Temperature	Operating virtual junction, T_J	-40	150	°C
	Operating ambient, T_A	-40	125	
	Storage, T_{stg}	-65	150	

- (1) Stresses beyond those listed under *Absolute Maximum Ratings* may cause permanent damage to the device. These are stress ratings only, which do not imply functional operation of the device at these or any other conditions beyond those indicated under *Recommended Operating Conditions*. Exposure to absolute-maximum-rated conditions for extended periods may affect device reliability.
- (2) As a result of the low dissipated power in this device, it is assumed that $T_J = T_A$.

6.2 ESD Ratings

		VALUE	UNIT
$V_{(ESD)}$ Electrostatic discharge	Human body model (HBM), per ANSI/ESDA/JEDEC JS-001 ⁽¹⁾	±2000	V
	Charged-device model (CDM), per JEDEC specification JESD22-C101 ⁽²⁾	±500	

- (1) JEDEC document JEP155 states that 500-V HBM allows safe manufacturing with a standard ESD control process.
- (2) JEDEC document JEP157 states that 250-V CDM allows safe manufacturing with a standard ESD control process.

6.3 Recommended Operating Conditions

Over operating junction temperature range (unless otherwise noted).

	MIN	NOM	MAX	UNIT
V_{DD}	1.8		6.5	V
$V_{SENSE}^{(1)}$	0		V_{DD}	V
V_{MR}	0		V_{DD}	V
V_{RESET}	0		6.5	V
$R_{PULL-UP}$	6.5	100	10,000	kΩ
T_J	-40	25	125	°C

- (1) All sense inputs.

6.4 Thermal Information

THERMAL METRIC ⁽¹⁾		TPS386596	UNIT
		DGK (VSSOP)	
		8 PINS	
$R_{\theta JA}$	Junction-to-ambient thermal resistance	174	°C/W
$R_{\theta JC(top)}$	Junction-to-case (top) thermal resistance	45.5	°C/W
$R_{\theta JB}$	Junction-to-board thermal resistance	94	°C/W
Ψ_{JT}	Junction-to-top characterization parameter	1.9	°C/W
Ψ_{JB}	Junction-to-board characterization parameter	92.7	°C/W
$R_{\theta JC(bot)}$	Junction-to-case (bottom) thermal resistance	N/A	°C/W

- (1) For more information about traditional and new thermal metrics, see the *Semiconductor and IC Package Thermal Metrics* application report, [SPRA953](#).

6.5 Electrical Characteristics

Over the operating temperature range of $T_J = -40^{\circ}\text{C}$ to 125°C . $1.8\text{ V} < V_{DD} < 6.5\text{ V}$, $R_{\overline{\text{RESET}}} = 100\text{ k}\Omega$ to V_{DD} , $C_{\overline{\text{RESET}}} = 50\text{ pF}$ to GND, unless otherwise noted. Typical values are at $T_J = 25^{\circ}\text{C}$.

PARAMETER		TEST CONDITIONS	MIN	TYP	MAX	UNIT
V_{DD}	Input supply		1.8		6.5	V
I_{DD}	Supply current (current into VDD pin)	$V_{CC} = 3.3\text{ V}$, $\overline{\text{RESET}}$ not asserted		7	19	μA
		$V_{CC} = 6.5\text{ V}$, $\overline{\text{RESET}}$ not asserted		7.5	22	μA
	Power-on reset voltage ^{(1) (2)}	$V_{OL(\text{max})} = 0.2\text{ V}$, $I_{\overline{\text{RESET}}} = 15\text{ }\mu\text{A}$			0.9	V
V_{ITn}	Negative-going input threshold accuracy	SENSE1	2.87	2.90	2.93	V
		SENSE2, SENSE3, SENSE4	396	400	404	mV
V_{HYS}	Hysteresis (positive-going) on V_{ITn}	SENSE1		25	72	mV
		SENSE2, SENSE3, SENSE4		3.5	10	mV
I_{SENSE1}	Input current at SENSE1	$V_{\text{SENSE1}} = 3.3\text{ V}$	2.2	2.75	3.3	μA
I_{SENSEn}	Input current at SENSEn pin, n = 2, 3, 4	$V_{\text{SENSEn}} = 0.42\text{ V}$	-25		25	nA
t_d	$\overline{\text{RESET}}$ delay time		30	50	70	ms
V_{IL}	$\overline{\text{MR}}$ logic low input		0		$0.3V_{DD}$	V
V_{IH}	$\overline{\text{MR}}$ logic high input		$0.7V_{DD}$			V
$R_{\text{MR_Pullup}}$	Internal pullup resistor on $\overline{\text{MR}}$ pin to V_{DD}			100		k Ω
V_{OL}	Low-level $\overline{\text{RESET}}$ output voltage	$I_{OL} = 1\text{ mA}$			0.4	V
		$\text{SENSEn} = 0\text{ V}$, $1.3\text{ V} < V_{DD} < 1.8\text{ V}$, $I_{OL} = 0.4\text{ mA}$ ⁽¹⁾			0.3	
I_{LKG}	$\overline{\text{RESET}}$ leakage current	$V_{\overline{\text{RESET}}} = 6.5\text{ V}$, $\overline{\text{RESET}}$ not asserted	-300		300	nA
C_{IN}	Input pin capacitance			5		pF

(1) These specifications are out of recommended V_{DD} range and only define $\overline{\text{RESET}}$ output performance during V_{DD} ramp up.

(2) The lowest supply voltage (V_{DD}) at which $\overline{\text{RESET}}$ becomes active. $t_{\text{RISE}(V_{DD})} \geq 15\text{ }\mu\text{s/V}$.

TPS386596

SLVSA75A –JULY 2010–REVISED AUGUST 2015

www.ti.com

6.6 Timing Requirements

Over the operating temperature range of $T_J = -40^\circ\text{C}$ to 125°C . $1.8\text{ V} < V_{DD} < 6.5\text{ V}$, $R_{\overline{\text{RESET}}} = 100\text{ k}\Omega$ to V_{DD} , $C_{\overline{\text{RESET}}} = 50\text{ pF}$ to GND, unless otherwise noted. Typical values are at $T_J = 25^\circ\text{C}$.

		MIN	NOM	MAX	UNIT
t_w	Input pulse width to SENSEn and MR pins	SENSEm: $1.05 V_{IT} \geq 0.95 V_{IT}$		4	μs
		MR: $0.7 V_{DD} \geq 0.3 V_{DD}$		50	ns

6.7 Switching Characteristics

Over the operating temperature range of $T_J = -40^\circ\text{C}$ to 125°C . $1.8\text{ V} < V_{DD} < 6.5\text{ V}$, $R_{\overline{\text{RESET}}} = 100\text{ k}\Omega$ to V_{DD} , $C_{\overline{\text{RESET}}} = 50\text{ pF}$ to GND, unless otherwise noted. Typical values are at $T_J = 25^\circ\text{C}$.

		MIN	TYP	MAX	UNIT
t_D	$\overline{\text{RESET}}$ delay time	30	50	70	ms

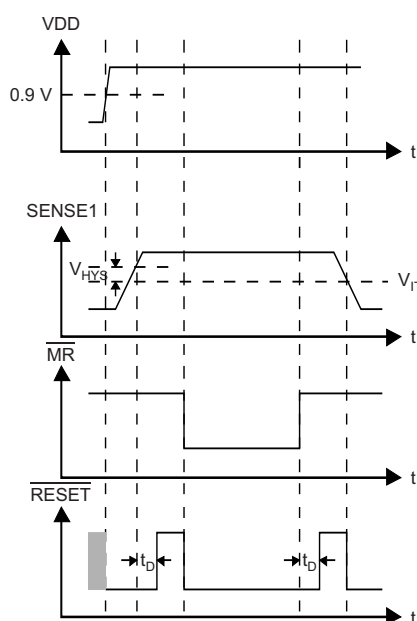

Figure 1. Timing Diagram

6.8 Typical Characteristics

At $T_A = 25^\circ\text{C}$, and $V_{DD} = 3.3\text{ V}$, unless otherwise noted.

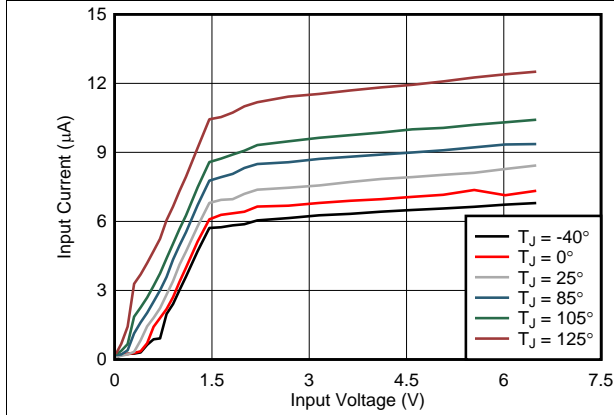

Figure 2. Supply Current vs Supply Voltage

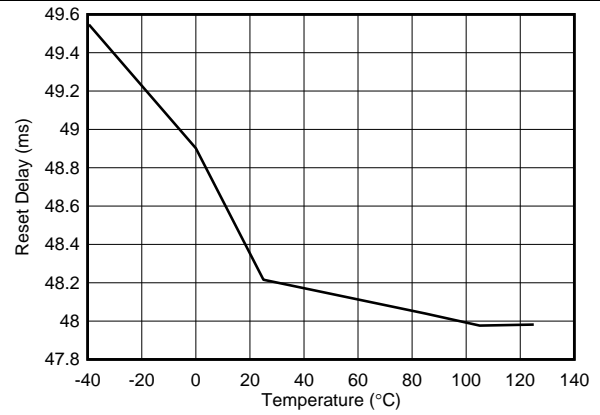

Figure 3. Reset Delay vs Temperature

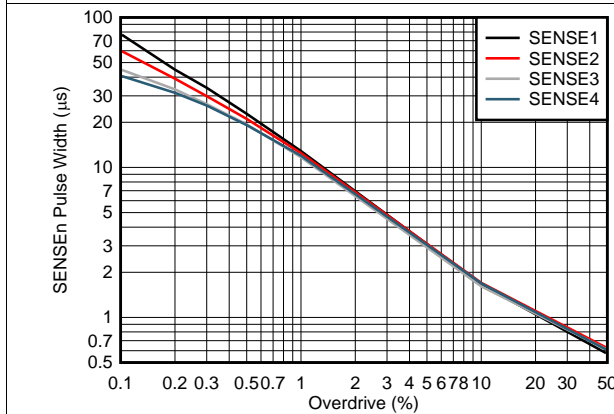

Figure 4. SENSEn Minimum Pulse Width vs SENSEn Threshold Overdrive Voltage

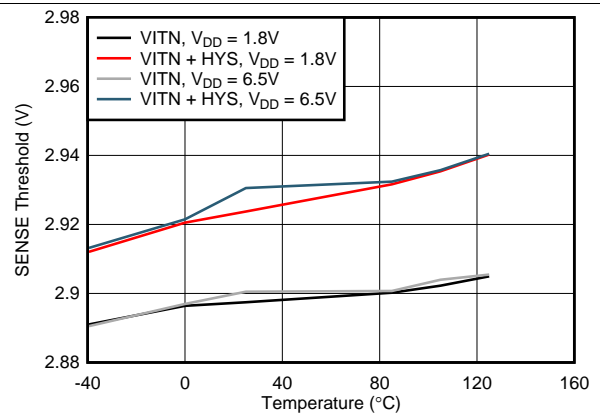

Figure 5. SENSE1 Threshold and Hysteresis vs Temperature

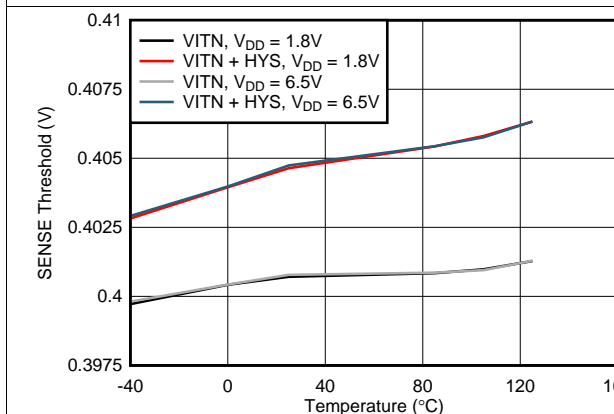

Figure 6. SENSE2 Threshold and Hysteresis vs Temperature

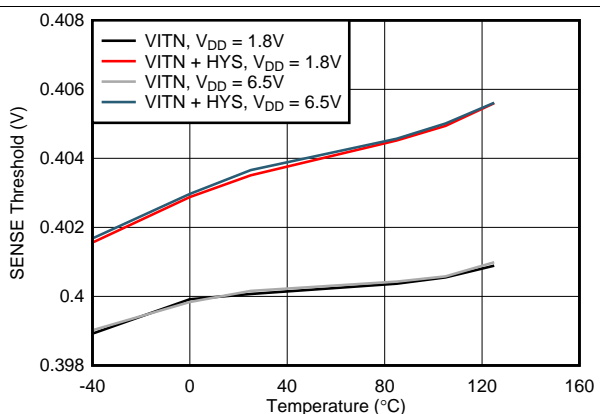

Figure 7. SENSE3 Threshold and Hysteresis vs Temperature

TPS386596

SLVSA75A – JULY 2010 – REVISED AUGUST 2015

www.ti.com

Typical Characteristics (continued)

At $T_A = 25^\circ\text{C}$, and $V_{DD} = 3.3\text{ V}$, unless otherwise noted.

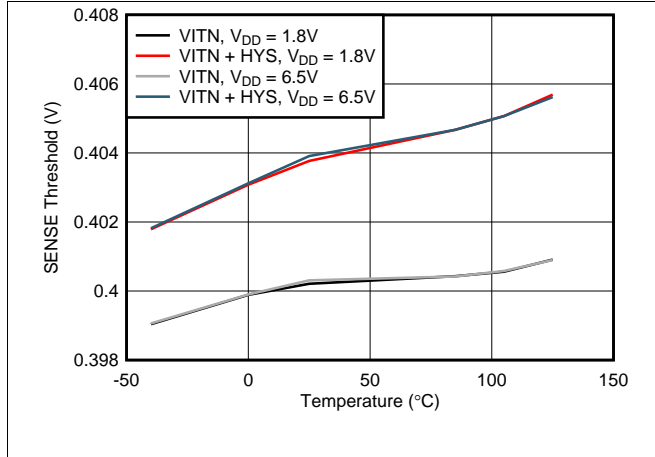

Figure 8. SENSE4 Threshold and Hysteresis vs Temperature

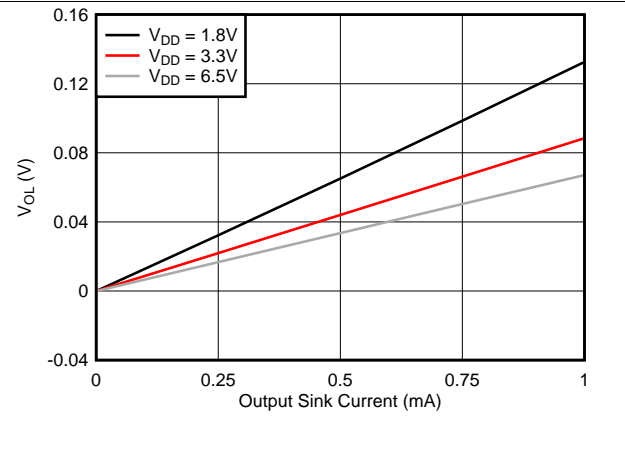

Figure 9. Output Voltage Low vs Output Current

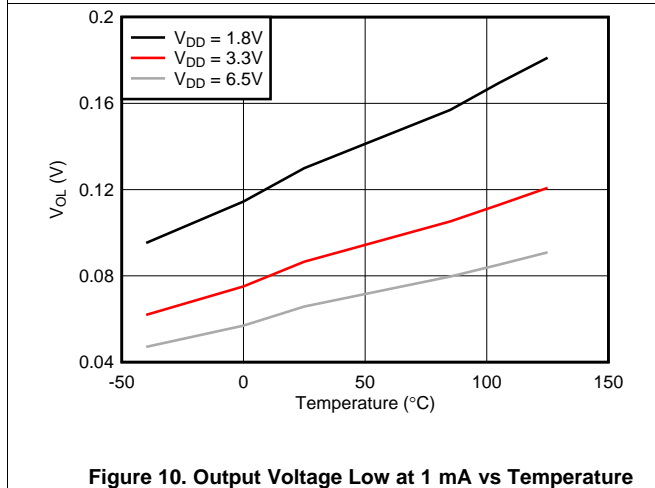

Figure 10. Output Voltage Low at 1 mA vs Temperature

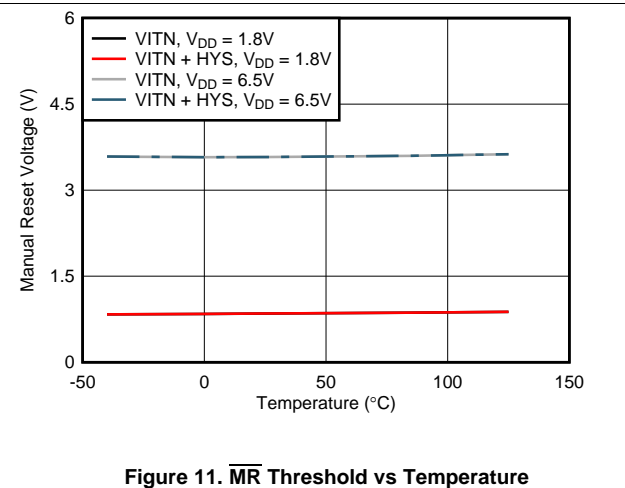

Figure 11. $\overline{\text{MR}}$ Threshold vs Temperature

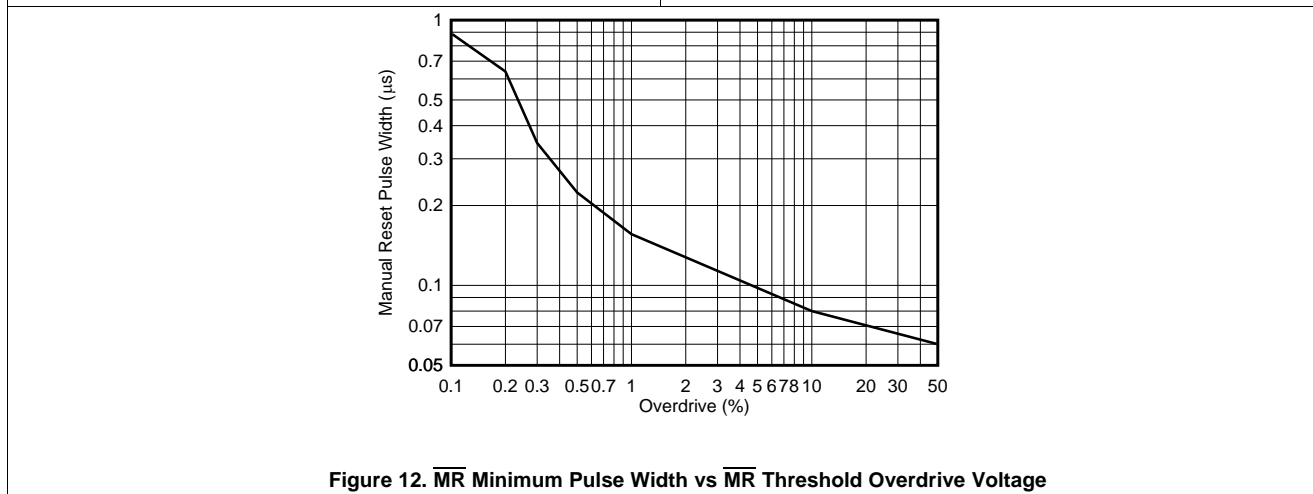
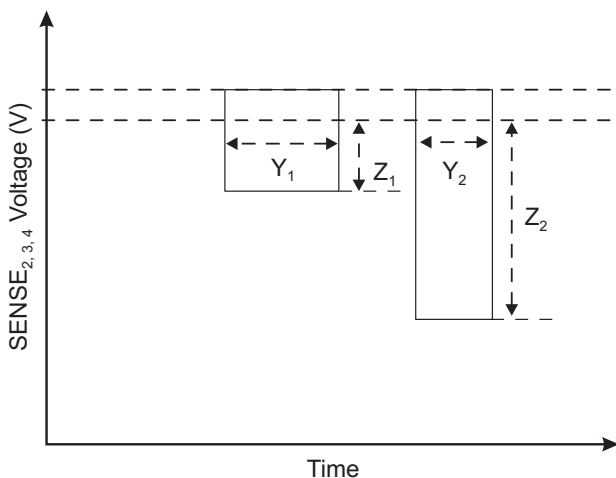

Figure 12. $\overline{\text{MR}}$ Minimum Pulse Width vs $\overline{\text{MR}}$ Threshold Overdrive Voltage

7 Parameter Measurement Information



$$X_1 = (Z_1/0.4) * 100(\%)$$

$$X_2 = (Z_2/0.4) * 100(\%)$$

$X_1 = X_2$ are overdrive (%) values calculated from actual SENSE_{2,3,4} voltage amplitudes measured as Z_1 and Z_2 .

Y_N is the minimum pulse width that gives RESET transition. Greater Z_N produces shorter Y_N .

Figure 13. Overdrive Measurement Method: Measurement Technique for Immunity to SENSE Pin Voltage Transient

TPS386596

SLVSA75A – JULY 2010 – REVISED AUGUST 2015

www.ti.com

8 Detailed Description

8.1 Overview

The TPS386596L33 multi-channel reset supervisor provides a complete single reset function for a four power supply system. The design of the SVS is based on the TPS386000 quad supervisor device series. The TPS386596 is designed to assert the RESET signal following the logic in Table 1. The RESET output remains asserted for a 50-ms delay time (t_d) after the event of reset release. The SENSE1 input has a fixed voltage threshold designed to monitor a 3.3-V nominal supply. The trip point, V_{IT1} , for SENSE1 is 2.90 V (typical). Each of the remaining SENSE_n inputs ($n = 2, 3, 4$) can be set to any voltage threshold greater than 0.4 V using an external resistor divider. An active-low manual reset (MR) input is also provided for asserting the RESET signal as desired by the system, regardless of the voltage on any of the SENSE pins.

8.2 Functional Block Diagram

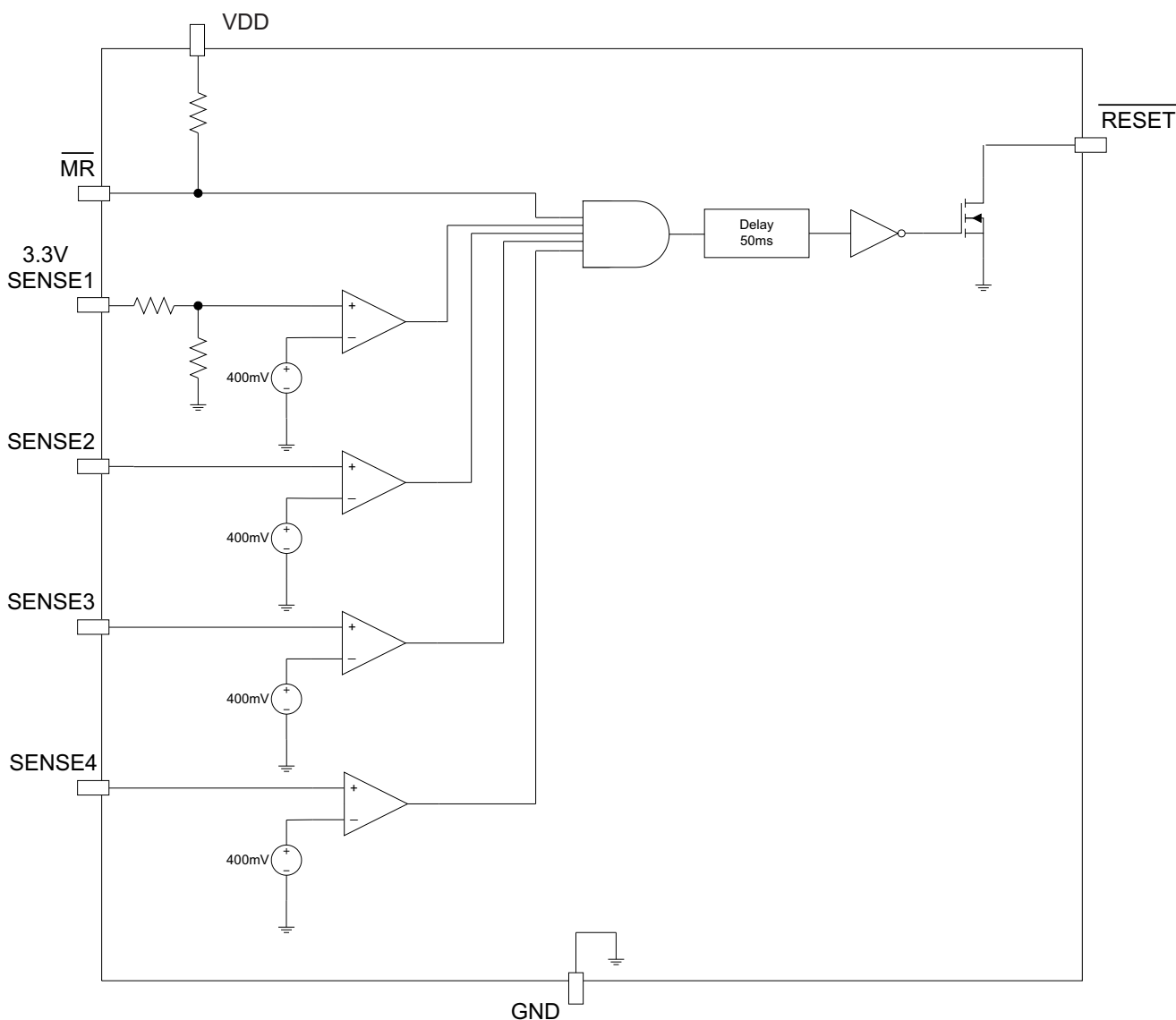

8.3 Feature Description

8.3.1 Voltage Monitoring

Each SENSE_n (n = 2, 3, 4) pin can be set to monitor any voltage threshold greater than 0.4 V using an external resistor divider. The SENSE1 pin is designed to monitor a 3.3-V supply with a 2.9-V threshold. A broad range of voltage thresholds can be supported, allowing these devices to be used in a wide array of applications.

The TPS386596 is relatively immune to short negative transients on the SENSE_n pin. Sensitivity to transients depends on threshold overdrive, as shown in the typical performance graph *TPS386596 SENSE_n Minimum Pulse Width vs SENSE_n Threshold Overdrive Voltage* (Figure 4).

8.3.2 Manual Reset

The manual reset $\overline{\text{MR}}$ input allows external logic signal from processors, other logic circuits, and/or discrete sensors to initiate a reset. The typical application of a TPS386596 has its $\overline{\text{RESET}}$ output connected to processor. A logic low at $\overline{\text{MR}}$ causes $\overline{\text{RESET}}$ to assert. After $\overline{\text{MR}}$ returns to a logic high and SENSE_n are above the respective voltage thresholds, $\overline{\text{RESET}}$ is released after a fixed 50-ms reset delay time. An internal 100-k Ω pullup to VDD is integrated on the $\overline{\text{MR}}$ input. There is also an internal 50-ns (typical) deglitch circuit.

8.3.3 Reset Output

In a typical application of the TPS386596, the $\overline{\text{RESET}}$ output is connected to the reset input of a processor (DSP, MCU, CPU, FPGA, ASIC, and so forth) or connected to the enable input of voltage regulators (DC-DC, LDO, and so forth).

The TPS386596 provides an open-drain reset output. Pullup resistors must be used to hold this line high when $\overline{\text{RESET}}$ is not asserted. By connecting a pullup resistor to the proper voltage rail (up to 6.5 V), the $\overline{\text{RESET}}$ output can be connected to other devices at the proper interface voltage level. The pullup resistor should be no smaller than 10 k Ω due to the finite impedance of the output transistor.

The $\overline{\text{RESET}}$ output is defined for $V_{\text{DD}} > 0.9$ V. To ensure that the target processor is properly reset, the V_{DD} supply input should be fed by the power rail and be available as early as possible in the application.

Table 1 shows a truth table of how the $\overline{\text{RESET}}$ output is asserted or released. Figure 1 provides a timing diagram that shows how $\overline{\text{RESET}}$ is asserted and deasserted in relation to $\overline{\text{MR}}$ and the SENSE_n inputs. Once the conditions are met, the transitions from the asserted state to the release state are performed after a fixed 50-ms delay time.

8.4 Device Functional Modes

Table 1 shows the device functional modes.

Table 1. $\overline{\text{RESET}}$ Truth Table

CONDITION		OUTPUT	
$\overline{\text{MR}} = \text{L}$	SENSE _n < VIT _n	$\overline{\text{RESET}} = \text{L}$	Reset asserted
$\overline{\text{MR}} = \text{L}$	SENSE _n > VIT _n	$\overline{\text{RESET}} = \text{L}$	Reset asserted
$\overline{\text{MR}} = \text{H}$	SENSE1 < VIT1 OR SENSE2 < VIT2 OR SENSE3 < VIT3 OR SENSE4 < VIT4	$\overline{\text{RESET}} = \text{L}$	Reset asserted
$\overline{\text{MR}} = \text{H}$	SENSE1 > VIT1 AND SENSE2 > VIT2 AND SENSE3 > VIT3 AND SENSE4 > VIT4	$\overline{\text{RESET}} = \text{H}$	Reset released

TPS386596

SLVSA75A – JULY 2010 – REVISED AUGUST 2015

www.ti.com

9 Application and Implementation

NOTE

Information in the following applications sections is not part of the TI component specification, and TI does not warrant its accuracy or completeness. TI's customers are responsible for determining suitability of components for their purposes. Customers should validate and test their design implementation to confirm system functionality.

9.1 Application Information

9.1.1 Undervoltage Detection

The SENSE_n inputs provide terminals at which the system voltages can be monitored. If the voltage at any one of the SENSE_n pins drops the respective V_{ITn} , then the RESET output is asserted. The comparators have a built-in hysteresis to ensure smooth RESET transitions.

It is good analog design practice to use a 1-nF to 10-nF bypass capacitor at the SENSE_n input to ground, to reduce sensitivity to transients, layout parasitics, and interference between power rails monitored by this device.

A typical connection of resistor dividers is show in Figure 14. SENSE1 is used to monitor a 3.3-V nominal power-supply voltage with a trip point equal to 2.90 V, and the remaining SENSE_n (n = 2, 3, 4) inputs can be used to monitor voltage rails down to 0.4 V. Threshold voltages can be calculated using the following equations.

$$V_{MON(2)} = (1 + RS2H/RS2L) \times 0.4 \text{ (V)} \tag{1}$$

$$V_{MON(3)} = (1 + RS3H/RS3L) \times 0.4 \text{ (V)} \tag{2}$$

$$V_{MON(4)} = (1 + RS4H/RS4L) \times 0.4 \text{ (V)} \tag{3}$$

9.2 Typical Application

Figure 14 shows a typical application for the TPS386956.

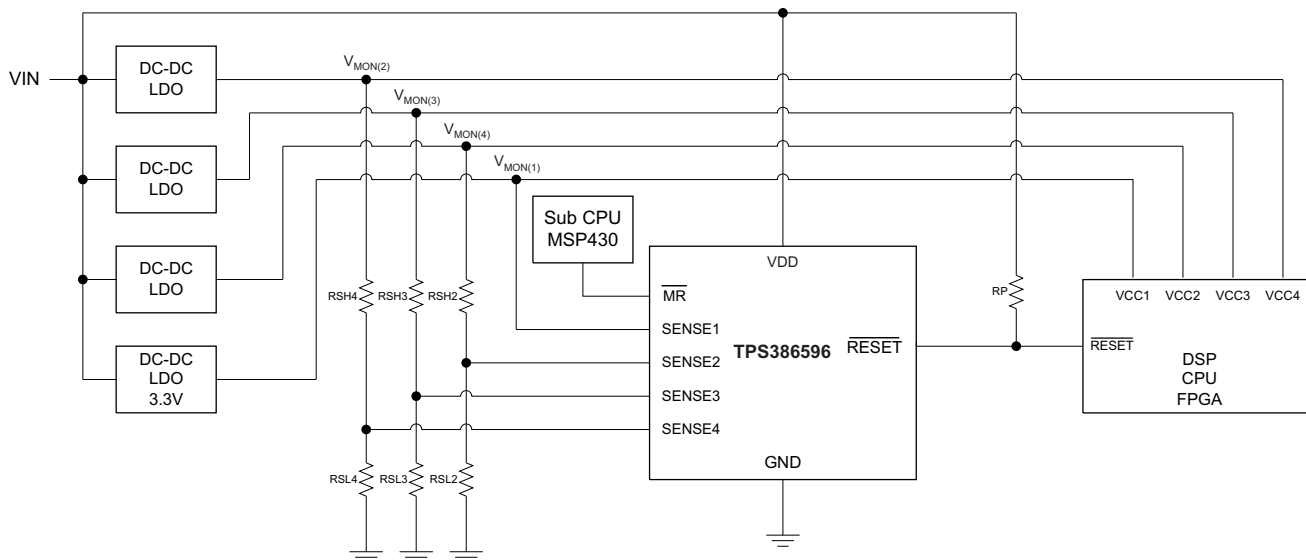

Figure 14. Typical Application Circuit

Typical Application (continued)

9.2.1 Design Requirements

This design is intended to monitor the voltage rails for an FPGA. Table 2 summarizes the design requirements.

Table 2. Design Requirements

PARAMETER	DESIGN REQUIREMENT
V _{DD}	5 V
V _{MON(1)}	3.3 V –10%
V _{MON(2)}	1.5 V –5%
V _{MON(3)}	1.2 V –5%
V _{MON(4)}	1 V –5%

9.2.2 Detailed Design Procedure

Select the pullup resistors to be 100 kΩ to ensure that V_{OL} ≤ 0.4 V.

Select R_{SnL} = 10 kΩ for all channels to ensure DC accuracy.

Use Equation 1 through Equation 3 to determine the values of R_{SnH} and R_{S4M}. Using standard 1% resistors, Table 3 shows the results:

Table 3. Design Results

RESISTOR	VALUE (kΩ)
RS1H	32.4
RS2H	25.5
RS3H	18.7
RS4H	14.3
RS4M	1

9.2.3 Application Curves

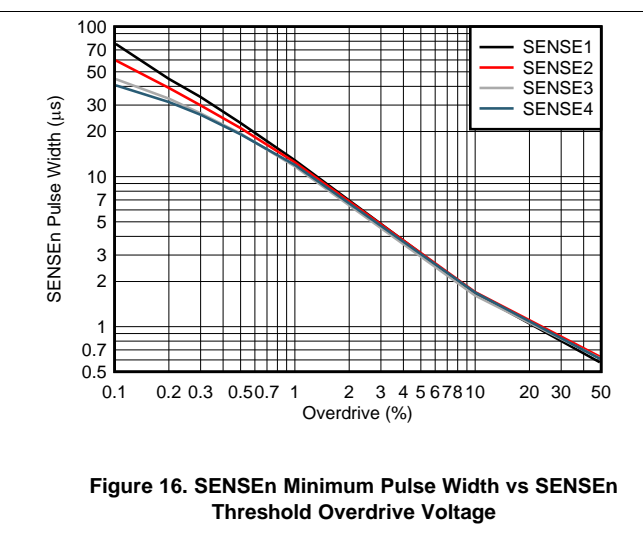
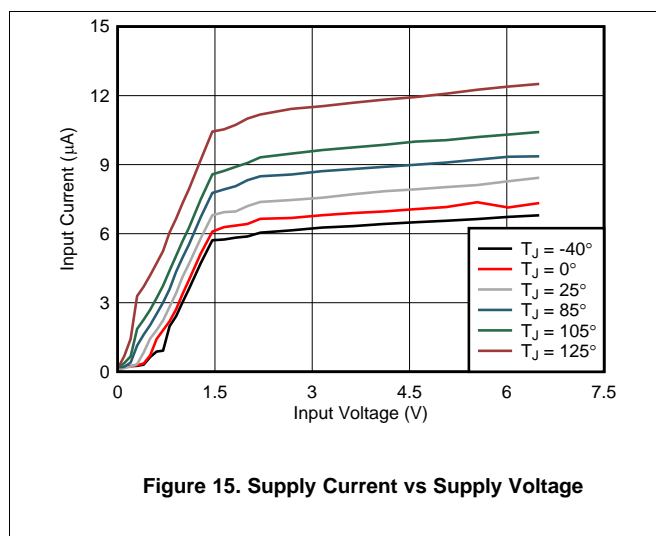

TPS386596

SLVSA75A – JULY 2010 – REVISED AUGUST 2015

www.ti.com

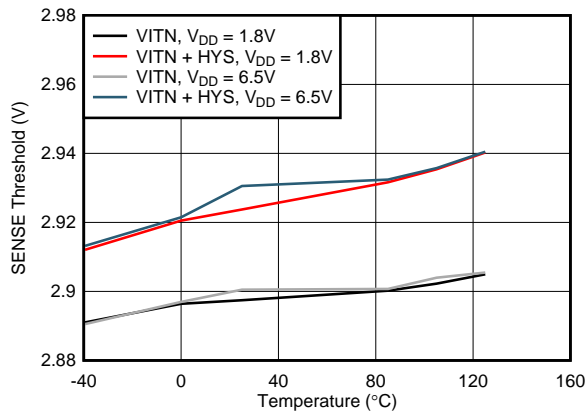

Figure 17. SENSE1 Threshold and Hysteresis vs Temperature

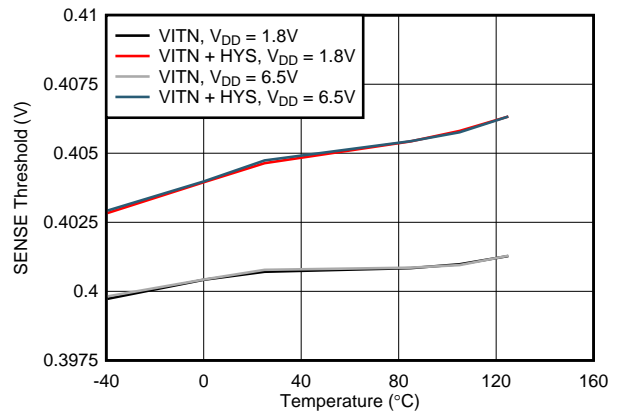

Figure 18. SENSE2 Threshold and Hysteresis vs Temperature

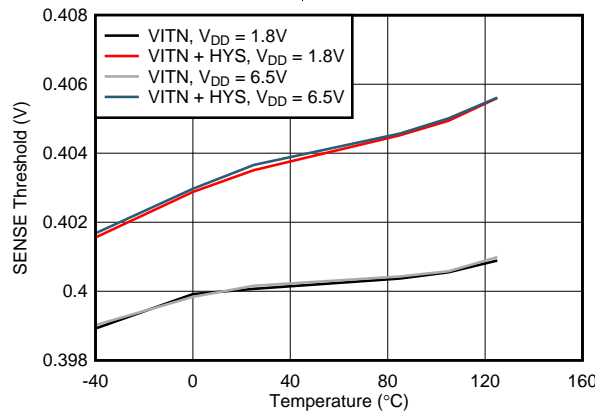

Figure 19. SENSE3 Threshold and Hysteresis vs Temperature

10 Power Supply Recommendations

The TPS386596 can operate from a 1.8-V to a 6.5-V input supply. A 0.1- μ F capacitor placed next to the VDD pin to the GND node is highly recommended. This power supply should not be less than 1.8 V in normal operation to ensure that the internal UVLO circuit does not assert reset.

11 Layout

11.1 Layout Guidelines

Follow these guidelines to lay out the printed-circuit-board (PCB) that is used for the TPS386596.

- Avoid long traces from the SENSE pin to the resistor divider. Instead, run the long traces from the RSnH to $V_{MON(n)}$.
- Place the V_{DD} decoupling capacitor (C_{VDD}) close to the device.
- Avoid using long traces for the V_{DD} supply node. The V_{DD} capacitor (C_{VDD}), along with parasitic inductance from the supply to the capacitor, can form an LC tank and create ringing with peak voltages above the maximum V_{DD} voltage.

11.2 Layout Example

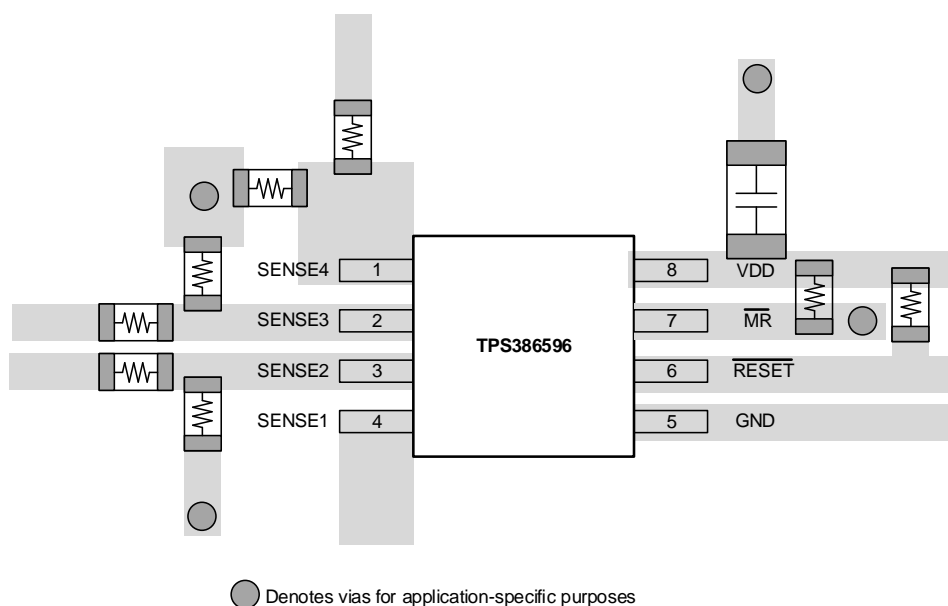

Figure 20. Example Layout (DGK Package)

TPS386596

SLVSA75A – JULY 2010 – REVISED AUGUST 2015

www.ti.com

12 Device and Documentation Support

12.1 Device Support

12.1.1 Development Support

12.1.1.1 Spice Models

Computer simulation of circuit performance using SPICE is often useful when analyzing the performance of analog circuits and systems. A SPICE model for the TPS386596 is available through the device product folders under *Simulation Models*.

12.1.2 Device Nomenclature

Table 4. Device Nomenclature⁽¹⁾

PRODUCT	DESCRIPTION
TPS386596xxx yyy z	xxx is device voltage option (for example, L33 = 3.3 V option) yyy is package designator z is package quantity

(1) For the most current package and ordering information see the Package Option Addendum at the end of this document, or see the TI website at www.ti.com.

12.2 Community Resources

The following links connect to TI community resources. Linked contents are provided "AS IS" by the respective contributors. They do not constitute TI specifications and do not necessarily reflect TI's views; see TI's [Terms of Use](#).

TI E2E™ Online Community *TI's Engineer-to-Engineer (E2E) Community*. Created to foster collaboration among engineers. At e2e.ti.com, you can ask questions, share knowledge, explore ideas and help solve problems with fellow engineers.

Design Support *TI's Design Support* Quickly find helpful E2E forums along with design support tools and contact information for technical support.

12.3 Trademarks

E2E is a trademark of Texas Instruments.
 All other trademarks are the property of their respective owners.

12.4 Electrostatic Discharge Caution



These devices have limited built-in ESD protection. The leads should be shorted together or the device placed in conductive foam during storage or handling to prevent electrostatic damage to the MOS gates.

12.5 Glossary



SLYZ022 — *TI Glossary*.

This glossary lists and explains terms, acronyms, and definitions.

13 Mechanical, Packaging, and Orderable Information

The following pages include mechanical, packaging, and orderable information. This information is the most current data available for the designated devices. This data is subject to change without notice and revision of this document. For browser-based versions of this data sheet, refer to the left-hand navigation.

PACKAGING INFORMATION

Orderable Device	Status (1)	Package Type	Package Drawing	Pins	Package Qty	Eco Plan (2)	Lead/Ball Finish (6)	MSL Peak Temp (3)	Op Temp (°C)	Device Marking (4/5)	Samples
TPS386596L33DGKR	ACTIVE	VSSOP	DGK	8	2500	Green (RoHS & no Sb/Br)	CU NIPDAU	Level-2-260C-1 YEAR	-40 to 125	PMXQ	
TPS386596L33DGKT	ACTIVE	VSSOP	DGK	8	250	Green (RoHS & no Sb/Br)	CU NIPDAU	Level-2-260C-1 YEAR	-40 to 125	PMXQ	

(1) The marketing status values are defined as follows:

ACTIVE: Product device recommended for new designs.

LIFEBUY: TI has announced that the device will be discontinued, and a lifetime-buy period is in effect.

NRND: Not recommended for new designs. Device is in production to support existing customers, but TI does not recommend using this part in a new design.

PREVIEW: Device has been announced but is not in production. Samples may or may not be available.

OBsolete: TI has discontinued the production of the device.

(2) Eco Plan - The planned eco-friendly classification: Pb-Free (RoHS), Pb-Free (RoHS Exempt), or Green (RoHS & no Sb/Br) - please check <http://www.ti.com/productcontent> for the latest availability information and additional product content details.

TBD: The Pb-Free/Green conversion plan has not been defined.

Pb-Free (RoHS): TI's terms "Lead-Free" or "Pb-Free" mean semiconductor products that are compatible with the current RoHS requirements for all 6 substances, including the requirement that lead not exceed 0.1% by weight in homogeneous materials. Where designed to be soldered at high temperatures, TI Pb-Free products are suitable for use in specified lead-free processes.

Pb-Free (RoHS Exempt): This component has a RoHS exemption for either 1) lead-based flip-chip solder bumps used between the die and package, or 2) lead-based die adhesive used between the die and leadframe. The component is otherwise considered Pb-Free (RoHS compatible) as defined above.

Green (RoHS & no Sb/Br): TI defines "Green" to mean Pb-Free (RoHS compatible), and free of Bromine (Br) and Antimony (Sb) based flame retardants (Br or Sb do not exceed 0.1% by weight in homogeneous material)

(3) MSL, Peak Temp. - The Moisture Sensitivity Level rating according to the JEDEC industry standard classifications, and peak solder temperature.

(4) There may be additional marking, which relates to the logo, the lot trace code information, or the environmental category on the device.

(5) Multiple Device Markings will be inside parentheses. Only one Device Marking contained in parentheses and separated by a "-" will appear on a device. If a line is indented then it is a continuation of the previous line and the two combined represent the entire Device Marking for that device.

(6) Lead/Ball Finish - Orderable Devices may have multiple material finish options. Finish options are separated by a vertical ruled line. Lead/Ball Finish values may wrap to two lines if the finish value exceeds the maximum column width.

Important Information and Disclaimer: The information provided on this page represents TI's knowledge and belief as of the date that it is provided. TI bases its knowledge and belief on information provided by third parties, and makes no representation or warranty as to the accuracy of such information. Efforts are underway to better integrate information from third parties. TI has taken and continues to take reasonable steps to provide representative and accurate information but may not have conducted destructive testing or chemical analysis on incoming materials and chemicals. TI and TI suppliers consider certain information to be proprietary, and thus CAS numbers and other limited information may not be available for release.



Distributor of Texas Instruments: Excellent Integrated System Limited

Datasheet of TPS386596L33DGKT - IC SUPERV MANUAL RESET QD 8VSSOP

Contact us: sales@integrated-circuit.com Website: www.integrated-circuit.com

PACKAGE OPTION ADDENDUM



www.ti.com

20-Mar-2015

In no event shall TI's liability arising out of such information exceed the total purchase price of the TI part(s) at issue in this document sold by TI to Customer on an annual basis.

TAPE AND REEL INFORMATION

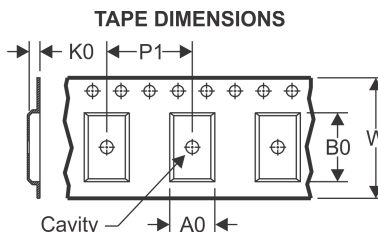
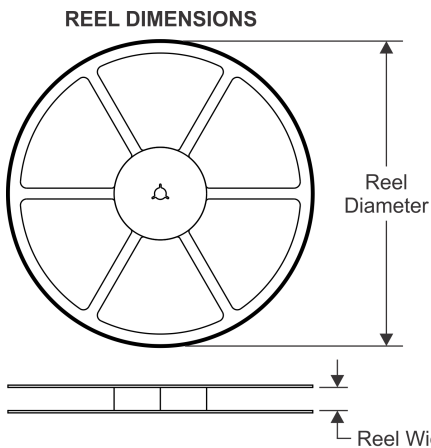

A0	Dimension designed to accommodate the component width
B0	Dimension designed to accommodate the component length
K0	Dimension designed to accommodate the component thickness
W	Overall width of the carrier tape
P1	Pitch between successive cavity centers

QUADRANT ASSIGNMENTS FOR PIN 1 ORIENTATION IN TAPE

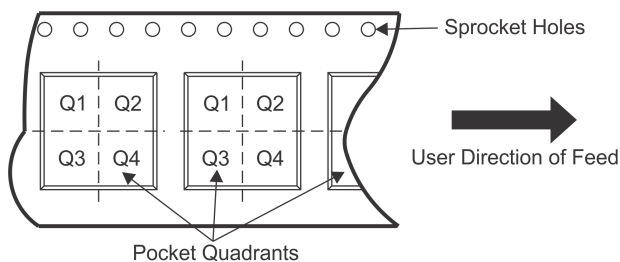

*All dimensions are nominal

Device	Package Type	Package Drawing	Pins	SPQ	Reel Diameter (mm)	Reel Width W1 (mm)	A0 (mm)	B0 (mm)	K0 (mm)	P1 (mm)	W (mm)	Pin1 Quadrant
TPS386596L33DGKR	VSSOP	DGK	8	2500	330.0	12.4	5.3	3.3	1.3	8.0	12.0	Q1
TPS386596L33DGKT	VSSOP	DGK	8	250	180.0	12.4	5.3	3.3	1.3	8.0	12.0	Q1

TAPE AND REEL BOX DIMENSIONS

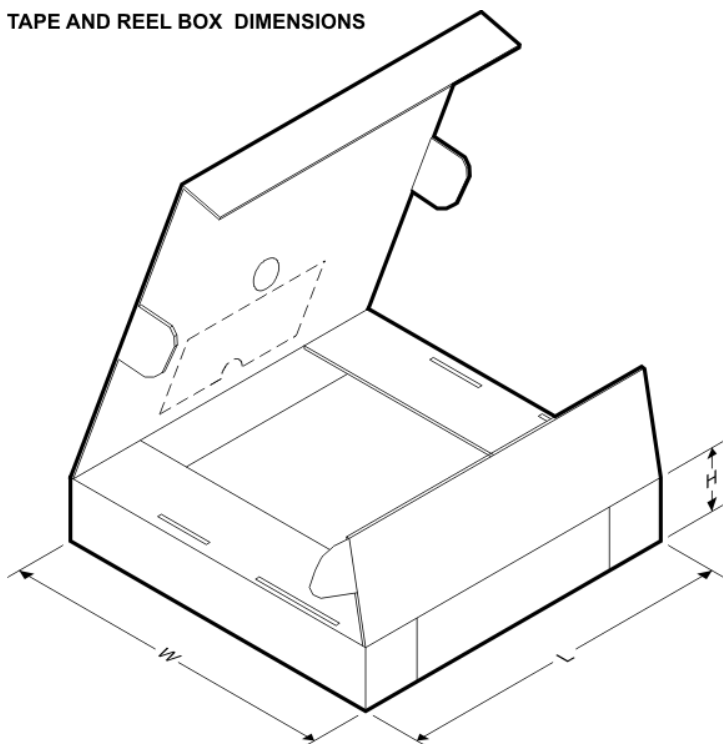

*All dimensions are nominal

Device	Package Type	Package Drawing	Pins	SPQ	Length (mm)	Width (mm)	Height (mm)
TPS386596L33DGKR	VSSOP	DGK	8	2500	370.0	355.0	55.0
TPS386596L33DGKT	VSSOP	DGK	8	250	195.0	200.0	45.0

MECHANICAL DATA

DGK (S-PDSO-G8)

PLASTIC SMALL-OUTLINE PACKAGE

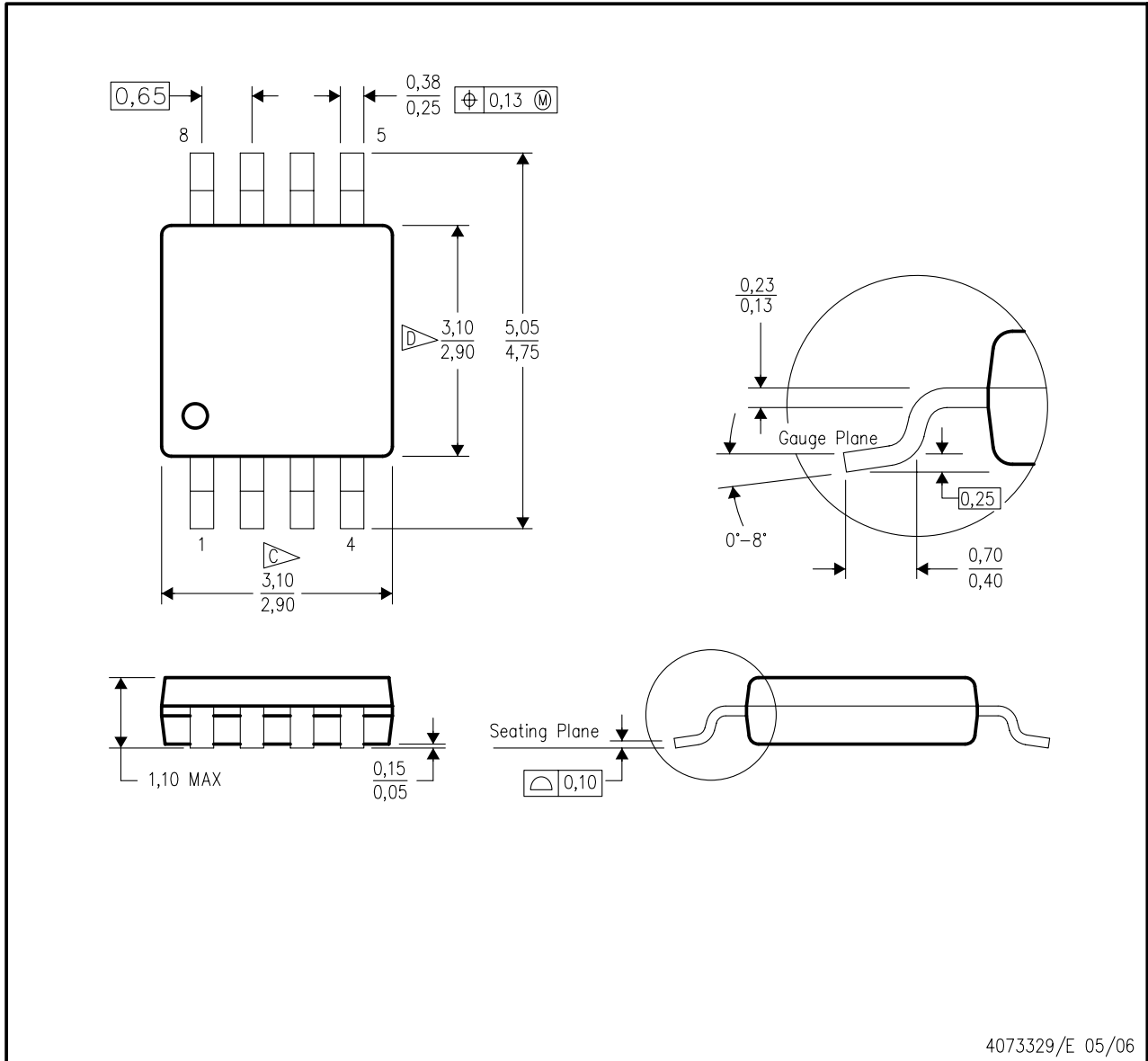

- NOTES:
- A. All linear dimensions are in millimeters.
 - B. This drawing is subject to change without notice.
 - C. Body length does not include mold flash, protrusions, or gate burrs. Mold flash, protrusions, or gate burrs shall not exceed 0.15 per end.
 - D. Body width does not include interlead flash. Interlead flash shall not exceed 0.50 per side.
 - E. Falls within JEDEC MO-187 variation AA, except interlead flash.

LAND PATTERN DATA

DGK (S-PDSO-G8)

PLASTIC SMALL OUTLINE PACKAGE

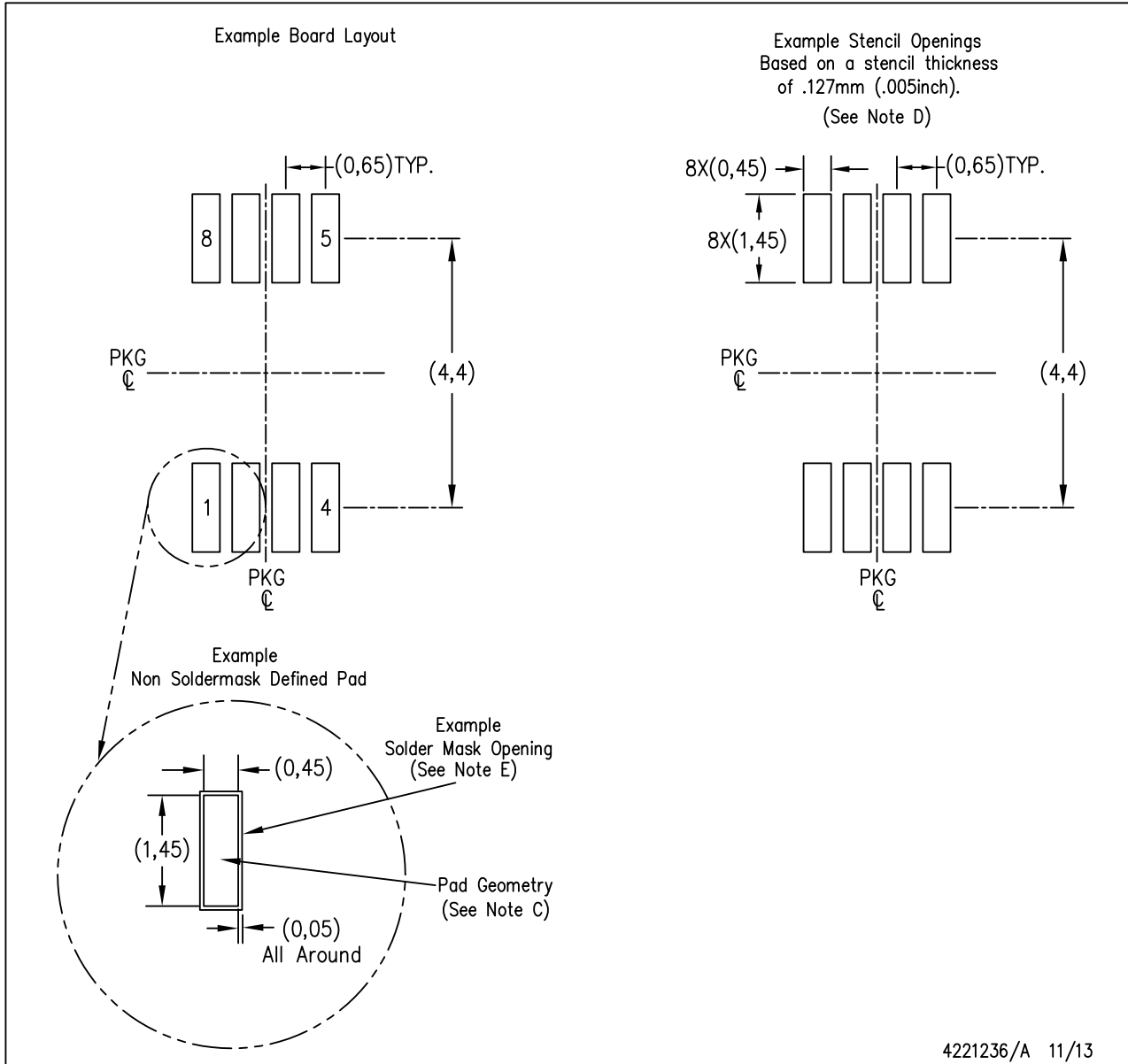

- NOTES:
- All linear dimensions are in millimeters.
 - This drawing is subject to change without notice.
 - Publication IPC-7351 is recommended for alternate designs.
 - Laser cutting apertures with trapezoidal walls and also rounding corners will offer better paste release. Customers should contact their board assembly site for stencil design recommendations. Refer to IPC-7525 for other stencil recommendations.
 - Customers should contact their board fabrication site for solder mask tolerances between and around signal pads.

IMPORTANT NOTICE

Texas Instruments Incorporated and its subsidiaries (TI) reserve the right to make corrections, enhancements, improvements and other changes to its semiconductor products and services per JESD46, latest issue, and to discontinue any product or service per JESD48, latest issue. Buyers should obtain the latest relevant information before placing orders and should verify that such information is current and complete. All semiconductor products (also referred to herein as “components”) are sold subject to TI’s terms and conditions of sale supplied at the time of order acknowledgment.

TI warrants performance of its components to the specifications applicable at the time of sale, in accordance with the warranty in TI’s terms and conditions of sale of semiconductor products. Testing and other quality control techniques are used to the extent TI deems necessary to support this warranty. Except where mandated by applicable law, testing of all parameters of each component is not necessarily performed.

TI assumes no liability for applications assistance or the design of Buyers’ products. Buyers are responsible for their products and applications using TI components. To minimize the risks associated with Buyers’ products and applications, Buyers should provide adequate design and operating safeguards.

TI does not warrant or represent that any license, either express or implied, is granted under any patent right, copyright, mask work right, or other intellectual property right relating to any combination, machine, or process in which TI components or services are used. Information published by TI regarding third-party products or services does not constitute a license to use such products or services or a warranty or endorsement thereof. Use of such information may require a license from a third party under the patents or other intellectual property of the third party, or a license from TI under the patents or other intellectual property of TI.

Reproduction of significant portions of TI information in TI data books or data sheets is permissible only if reproduction is without alteration and is accompanied by all associated warranties, conditions, limitations, and notices. TI is not responsible or liable for such altered documentation. Information of third parties may be subject to additional restrictions.

Resale of TI components or services with statements different from or beyond the parameters stated by TI for that component or service voids all express and any implied warranties for the associated TI component or service and is an unfair and deceptive business practice. TI is not responsible or liable for any such statements.

Buyer acknowledges and agrees that it is solely responsible for compliance with all legal, regulatory and safety-related requirements concerning its products, and any use of TI components in its applications, notwithstanding any applications-related information or support that may be provided by TI. Buyer represents and agrees that it has all the necessary expertise to create and implement safeguards which anticipate dangerous consequences of failures, monitor failures and their consequences, lessen the likelihood of failures that might cause harm and take appropriate remedial actions. Buyer will fully indemnify TI and its representatives against any damages arising out of the use of any TI components in safety-critical applications.

In some cases, TI components may be promoted specifically to facilitate safety-related applications. With such components, TI’s goal is to help enable customers to design and create their own end-product solutions that meet applicable functional safety standards and requirements. Nonetheless, such components are subject to these terms.

No TI components are authorized for use in FDA Class III (or similar life-critical medical equipment) unless authorized officers of the parties have executed a special agreement specifically governing such use.

Only those TI components which TI has specifically designated as military grade or “enhanced plastic” are designed and intended for use in military/aerospace applications or environments. Buyer acknowledges and agrees that any military or aerospace use of TI components which have **not** been so designated is solely at the Buyer’s risk, and that Buyer is solely responsible for compliance with all legal and regulatory requirements in connection with such use.

TI has specifically designated certain components as meeting ISO/TS16949 requirements, mainly for automotive use. In any case of use of non-designated products, TI will not be responsible for any failure to meet ISO/TS16949.

Products

Audio	www.ti.com/audio
Amplifiers	amplifier.ti.com
Data Converters	dataconverter.ti.com
DLP® Products	www.dlp.com
DSP	dsp.ti.com
Clocks and Timers	www.ti.com/clocks
Interface	interface.ti.com
Logic	logic.ti.com
Power Mgmt	power.ti.com
Microcontrollers	microcontroller.ti.com
RFID	www.ti-rfid.com
OMAP Applications Processors	www.ti.com/omap
Wireless Connectivity	www.ti.com/wirelessconnectivity

Applications

Automotive and Transportation	www.ti.com/automotive
Communications and Telecom	www.ti.com/communications
Computers and Peripherals	www.ti.com/computers
Consumer Electronics	www.ti.com/consumer-apps
Energy and Lighting	www.ti.com/energy
Industrial	www.ti.com/industrial
Medical	www.ti.com/medical
Security	www.ti.com/security
Space, Avionics and Defense	www.ti.com/space-avionics-defense
Video and Imaging	www.ti.com/video

TI E2E Community

e2e.ti.com