



Excellent Integrated System Limited

Stocking Distributor

Click to view price, real time Inventory, Delivery & Lifecycle Information:

[Essentra Components \(formerly Richco, Inc.\)](#)
[WIT-18RA-4-01-M](#)

For any questions, you can email us directly:
sales@integrated-circuit.com

PART NO.	DIM. "A"
WIT-18RA-4-01-M	1/4"(6.4)

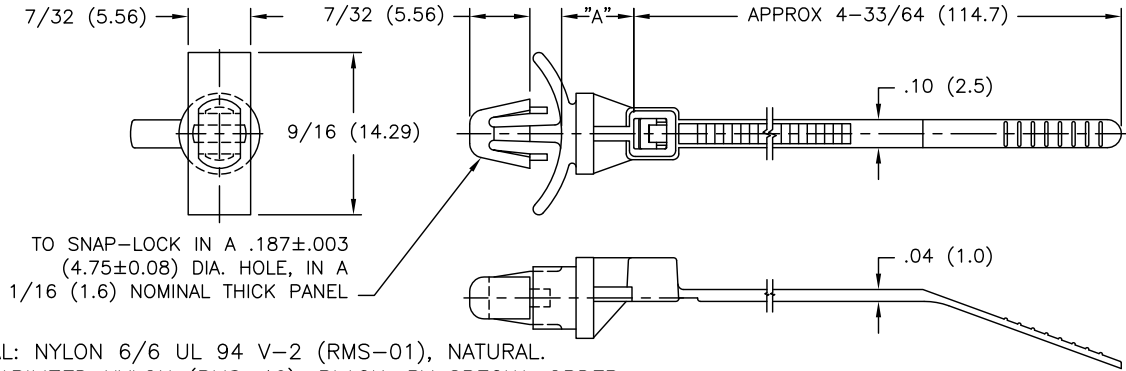

NOTES:

- MATERIAL: NYLON 6/6 UL 94 V-2 (RMS-01), NATURAL.
-UV STABILIZED NYLON (RMS-46), BLACK. BY SPECIAL ORDER.
-NYLON 4/6 HIGH TEMPERATURE (RMS-109) AVAILABLE BY SPECIAL ORDER. TO ORDER REPLACE "-01" WITH "-HT".
- MIN. LOOP TENSILE: 18 LBS (80 NEWTONS).
- MAX. BUNDLE DIAMETER: 3/4 (19.1).
- THE SUFFIX "-M" IS FOR PACKAGING OF 1000 PCS

H	SEE CO 200698 FOR CHANGES	SK 08.16.11	TITLE: SELF MOUNT WRAP-IT-TIES	DWG IN IN (MM)	FINAL	PART #	PRINT TYPE	
G	SEE CO 200661 FOR CHANGES	SK 05.12.11						
F	SEE CO 200557 FOR CHANGES	SK 07.19.10						
E	SEE CO 200445 FOR CHANGES	SK 09.23.09						
D	SEE CO 200134 FOR CHANGES	SK 02.28.08						
C	COMPLETELY RE-DRAWN; NEW NOTES AND CHANGED FILE NO.	SM 03.15.01	FILE # WIT-18RA	DWN: S.M.	APP:	SEE TABLE	CA	
B	ADDED NOTE 6.	SM 02.23.01	MAT'L: SEE NOTES	DT: 03/15/01	DT:			
A	MAT'L UV NYLON (RMS-46) ADDED	JL 01.18.00	RE: RICHCO, INC.	RICHCO INC. PO BOX 804238, CHICAGO, 60680 (773) 539-4060				
REV	DESCRIPTION	ENGR DATE	TOLERANCES UNLESS NOTED .XX=±.010 .XXX=±.005 FRAC=±1/64 ANG=±1°					