

## Excellent Integrated System Limited

Stocking Distributor

Click to view price, real time Inventory, Delivery & Lifecycle Information:

[Phoenix Contact](#)  
[1693487](#)

For any questions, you can email us directly:

[sales@integrated-circuit.com](mailto:sales@integrated-circuit.com)



Extract from the online catalog

## SAC-5P-1,5-PUR/AD-2L

This product has been replaced by a newer version.

Order No.: 1693487



<http://eshop.phoenixcontact.de/phoenix/treeViewClick.do?UID=1693487>

Sensor/Actuator cable, 5-position, PUR/PVC, Black RAL 9005, Free conductor end, on Valve plug A (pressure switch), with 2 LEDs, Cable length: 1.5 m

Commercial data	
GTIN (EAN)	 4 017918 173333
Note	Made-to-order
sales group	D113
Pack	1 pcs.
Customs tariff	85444290
Catalog page information	Page 90 (PC-2007)

### Product notes

WEEE/RoHS-compliant since:  
01/01/2008



<http://www.download.phoenixcontact.com>  
Please note that the data given here has been taken from the online catalog. For comprehensive information and data, please refer to the user documentation. The General Terms and Conditions of Use apply to Internet downloads.

### Certificates / Approvals



Certification

GOST

SAC-5P-1,5-PUR/AD-2L Order No.: 1693487

<http://eshop.phoenixcontact.de/phoenix/treeViewClick.do?UID=1693487>

**Diagrams/Drawings**

Dimensioned drawing

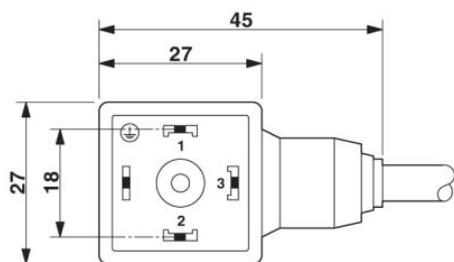

Valve plug type AD

Circuit diagram

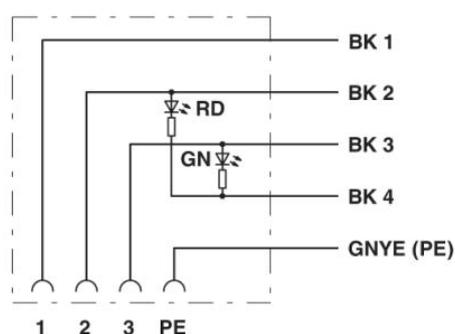

Contact assignment of valve connector

Schematic diagram

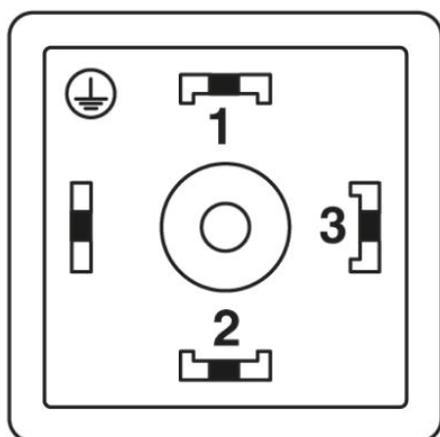

Valve plug connector pin assignment, type AD

SAC-5P-1,5-PUR/AD-2L Order No.: 1693487

<http://eshop.phoenixcontact.de/phoenix/treeViewClick.do?UID=1693487>

---

#### Address

PHOENIX CONTACT Deutschland GmbH  
Flachsmarktstr. 8  
32825 Blomberg, Germany  
Phone +49 5235 3 12000  
Fax +49 5235 3 41200  
<http://www.phoenixcontact.de>



© 2011 Phoenix Contact  
Technical modifications reserved;