

Excellent Integrated System Limited

Stocking Distributor

Click to view price, real time Inventory, Delivery & Lifecycle Information:

[Intersil](#)

[ISL28433SOICEVAL1Z](#)

For any questions, you can email us directly:

sales@integrated-circuit.com

ISL28433SOICEVAL1Z, ISL28433TSSOPEVAL1Z Evaluation Board User's Guide

Introduction

The ISL28433SOICEVAL1Z and ISL28433TSSOPEVAL1Z Evaluation Board is designed to evaluate the performance of the ISL28433 Chopper Stabilized op amp. The evaluation board contains the circuitry needed to evaluate the high performance of the ISL28433 amplifier. The ISL28433 chopper stabilized rail-to-rail quad op amp features a low 8 μ V maximum V_{OS} over-temperature and a 0.1Hz 1/f noise corner frequency enabling very high gain single-stage DC amplifiers that can operate from single cell batteries while consuming only 20 μ A of current. The ISL28433SOICEVAL1Z and ISL28433TSSOPEVAL1Z evaluation board can be configured as a precision high-gain ($G = 10,000V/V$) differential amplifier and demonstrates the level of performance possible with this type of amplifier while operating from battery voltages as low as 1.65V.

Reference Documents

- ISL28233, ISL28433 Data Sheet; [FN7692](#)

Evaluation Board Key Features

- Single Supply Operation: +1.65V to +5.5V
- Dual Supply Operation: $\pm 0.825V$ to $\pm 2.75V$
- Singled-Ended or Differential Input Operation with High Gain ($G = 10,000V/V$)
- External VREF input
- Banana Jack Connectors for Power Supply and VREF Inputs
- BNC Connectors for Op Amp Input and Output Terminals
- Convenient PCB Pads for Op Amp Input/Output Impedance Loading

Power Supplies (Figure 1)

External power connections are made through the V+, V-, VREF, and GND connections on the evaluation board. The circuit can operate from a single supply or from dual supplies. For single supply operation, the V- and GND pins are tied together to the negative or ground reference of the power supply. For split supplies, V+ and V- terminals connect to their respective supply terminals. De-coupling capacitors C1 and C2 provide low-frequency power-supply filtering, while additional capacitors, C3 and C4, which are connected close to the part, filter out high frequency noise. Anti-reverse diodes D1 and D2 (optional) protects the circuit in the momentary case of accidentally reversing the power supplies to the evaluation board. The VREF pin can be connected to ground to establish a ground referenced input for split supply operation, or can be externally set to any reference level for single supply operation.

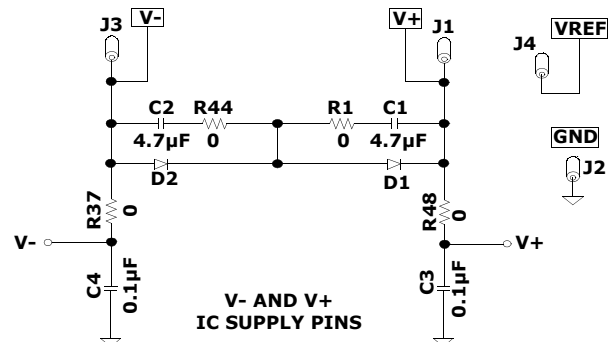

FIGURE 1. POWER SUPPLY CIRCUIT

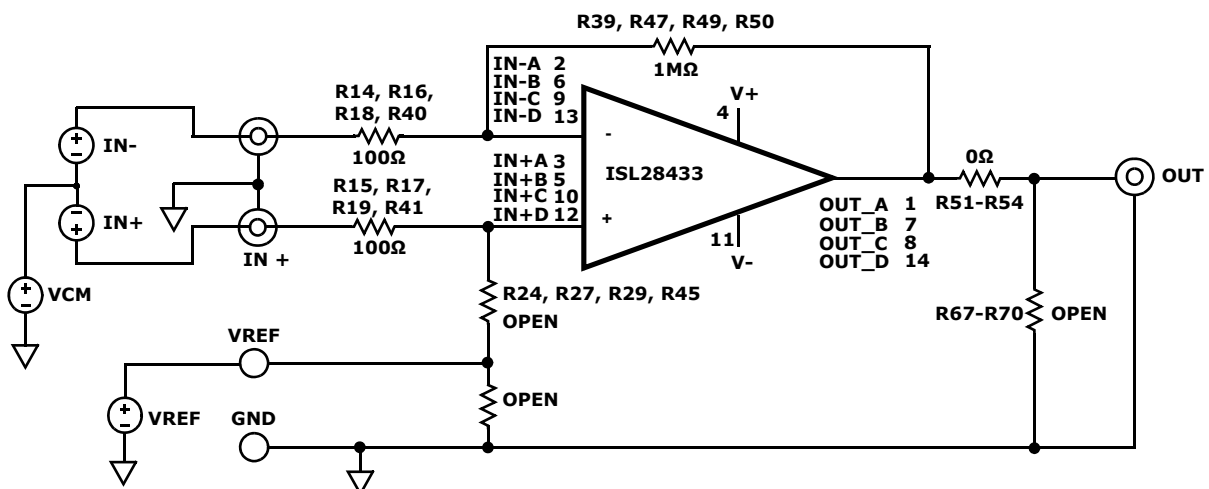

FIGURE 2. BASIC DIFFERENTIAL AMPLIFIER CONFIGURATION

Application Note 1575

Amplifier Configuration (Figure 3)

The schematic of the op amp input stage with the components supplied is shown in Figure 3, with a closed loop gain of 10,000V/V. The circuit implements a Hi-Z differential input with unbalanced common mode impedance. The differential amplifier gain is expressed in Equation 1:

$$V_{OUT} = (V_{IN+} - V_{IN-}) \cdot (R_F / R_{IN}) + V_{REF} \quad (EQ. 1)$$

For single-ended input with an inverting gain $G = -10,000V/V$, the IN+ input is grounded and the signal is supplied to the IN- input. VREF must be connected to a reference voltage between the V+ and V- supply rails. For non-inverting operation with $G = 10,001V/V$, the IN- input is grounded and the signal is supplied to the IN+ input. The non-inverting gain is strongly dependent on any resistance from IN- to GND. For good gain accuracy, a 0Ω resistor should be installed on the empty R11 pad.

User-selectable Options (Figures 3 and 4)

Component pads are included to enable a variety of user-selectable circuits to be added to the amplifier inputs, the VREF input, outputs and the amplifier feedback loops.

A voltage divider can be added to establish a power supply-tracking common mode reference using the VREF input (see "ISL28433SOICEVAL1Z Schematic Diagram" on page 4). The inverting and non-inverting inputs have

additional resistor and capacitor placements for adding input attenuation or feedback capacitors (Figure 3).

The output (Figure 4) also has additional resistor and capacitor placements for filtering and loading.

NOTE: Operational amplifiers are sensitive to output capacitance and may oscillate. In the event of oscillation, reduce output capacitance by using shorter cables, or add a resistor in series with the output.

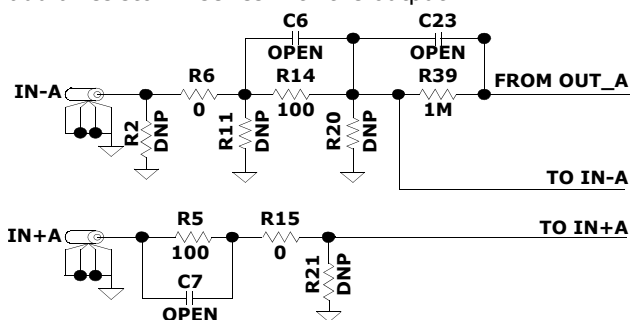

FIGURE 3. INPUT STAGE

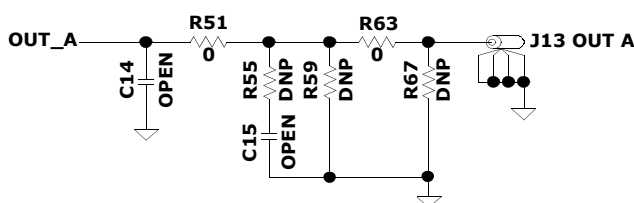

FIGURE 4. OUTPUT STAGE

TABLE 1. ISL28433TSSOPEVAL1Z and ISL28433MSOPEVAL1Z COMPONENTS PARTS LIST

DEVICE #	DESCRIPTION	COMMENTS
C1, C2	CAP, SMD, 1210, 4.7μF, 50V, 10%, X7R, ROHS	Power Supply Decoupling
C3, C4	CAP, SMD, 0805, 0.1μF, 50V, 10%, X7R, ROHS	Power Supply Decoupling
D1, D2	40V SCHOTTKY BARRIER DIODE	Reverse Power Protection
R32, R33	RESISTOR, SMD, 0603, DNP, 1%, ROHS	VREF Resistor Divider
C5	CAP, SMD, 1210, 4.7μF, 50V, 10%, X7R, ROHS	VREF Supply Decoupling
R5, R7, R9, R14, R16, R18, R35, R40	RESISTOR, SMD, 0603, 100Ω, 1%, 1/16W, ROHS	Gain Setting Resistor
R39, R47, R49, R50	RESISTOR, SMD, 0603, 10MΩ, 1%, 1/16W, ROHS	Gain Setting Feedback Resistor
R2-R4, R11-R13, R20-R23, R25, R26, R34, R38, R42, R43, R55-R58, R67-70, R24, R27-R31, R33, R45, R46, R59-R62	RESISTOR, SMD, 0603, DNP-PLACE HOLDER, ROHS	User selectable resistors - not populated
U1 (ISL28433)	ISL28433FBZ (SOIC), ISL28433FVZ (TSSOP), IC-RAIL-TO-RAIL OP AMP, ROHS	

Application Note 1575

ISL28433SOICEVAL1Z Top View

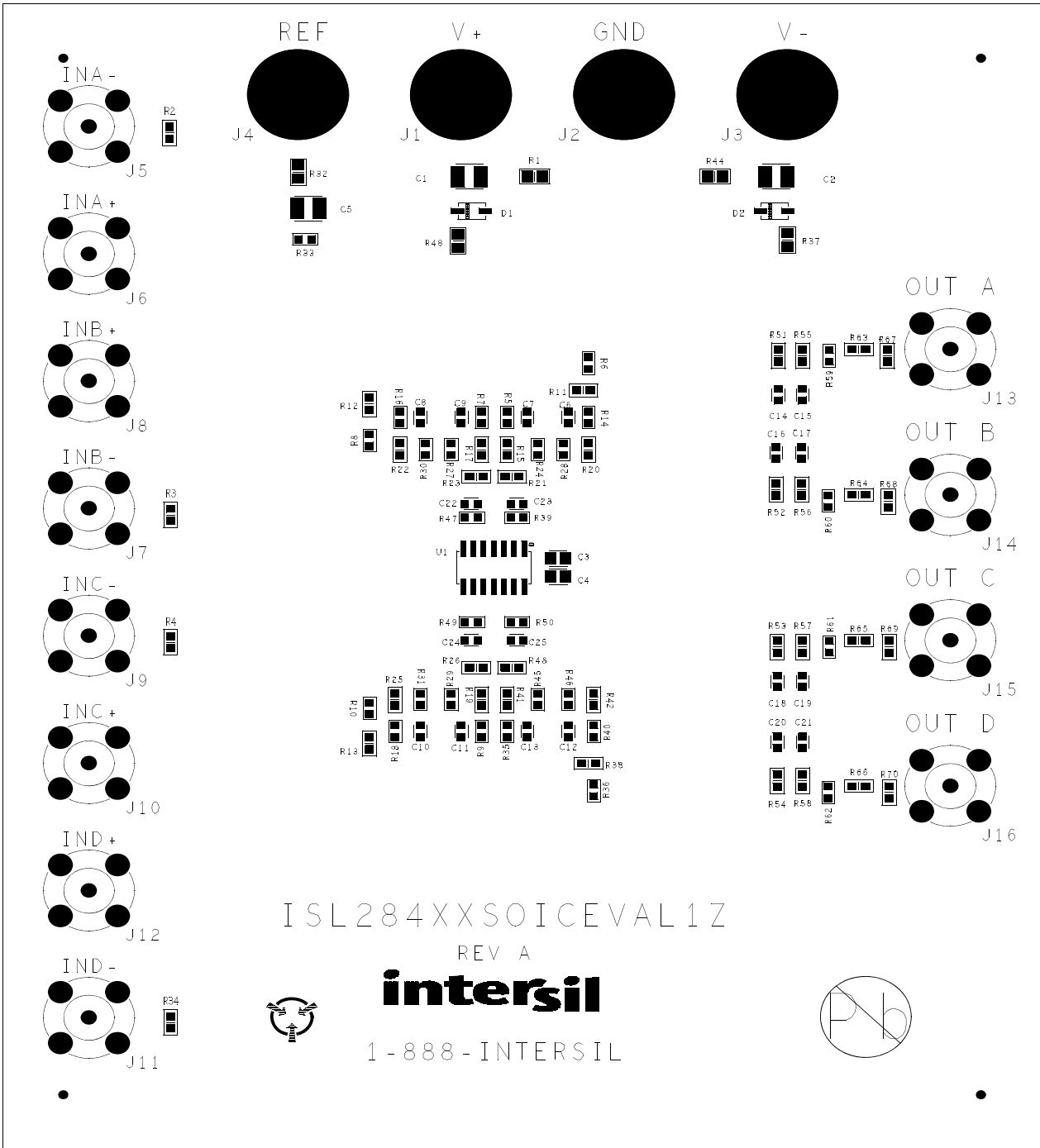

Intersil Corporation reserves the right to make changes in circuit design, software and/or specifications at any time without notice. Accordingly, the reader is cautioned to verify that the Application Note or Technical Brief is current before proceeding.

For information regarding Intersil Corporation and its products, see www.intersil.com

ISL28433SOICEVAL1Z Schematic Diagram

