

## Excellent Integrated System Limited

Stocking Distributor

Click to view price, real time Inventory, Delivery & Lifecycle Information:

[TT Electronics/BI](#)  
[PS100-2B1AR10K](#)

For any questions, you can email us directly:

[sales@integrated-circuit.com](mailto:sales@integrated-circuit.com)

Model PS100  
 Slide Potentiometer  
 Single / Dual Gang  
 100 mm Travel  
 100,000 Cycle Life  
 Metal Shaft  
 RoHS Compliant

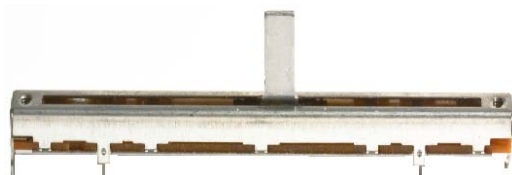

**MODEL STYLE**

Single Gang , 100mm Travel	PS100 -1
Dual Gang , 100mm Travel	PS100 -2

**ELECTRICAL<sup>1</sup>**

Resistance Range, Ohms	500 -1M
Standard Resistance Tolerance	± 20%
Resistance Tapers	A,B,C
Residual Resistance, Max.	Term. 1-2 : 10 ohms, Term 2-3: 30 ohms
Input Voltage, Maximum	200Vdc
Power rating, Watts	Linear B taper: 0.25W Other tapers: 0.125W
Dielectric Strength	300Vac, 1 minute
Insulation Resistance, Minimum	100M ohms at 250Vdc/ 1 minute
Sliding Noise	Less than 100mV
Gang Error	±3dB (-40dB to 0dB)

**MECHANICAL**

Static Stop Strength, Minimum	10.0 Kgf-cm
Operating Force	30gf max.

**DURABILITY**

Sliding Life	100,000 cycles
--------------	----------------

<sup>1</sup> Specifications subject to change without notice.

## Model PS100

### ORDERING INFORMATION<sup>2</sup>

#### Model PS100

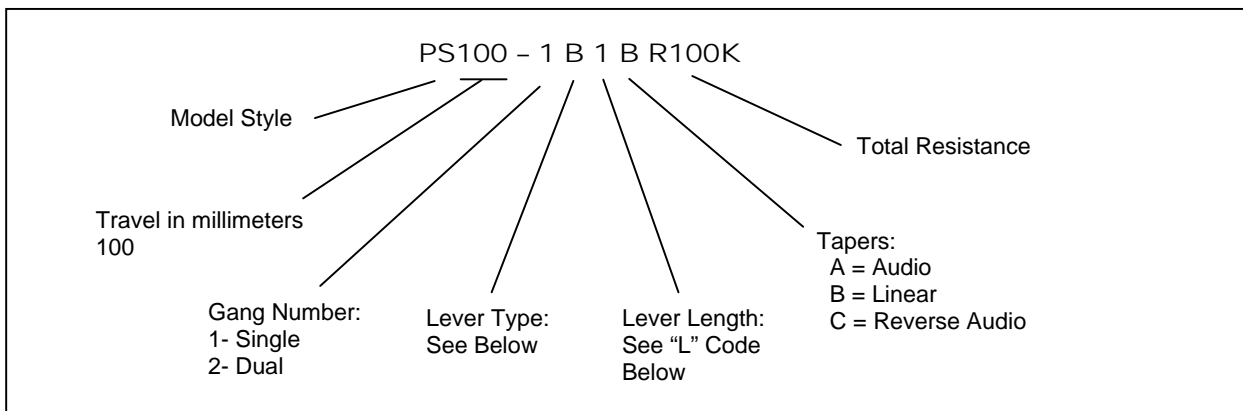

### STANDARD RESISTANCE VALUES, OHMS

500	1K	2K	5K	10K	20K	50K	100K	200K	500K	1 MEG
-----	----	----	----	-----	-----	-----	------	------	------	-------

#### Metal Lever Types

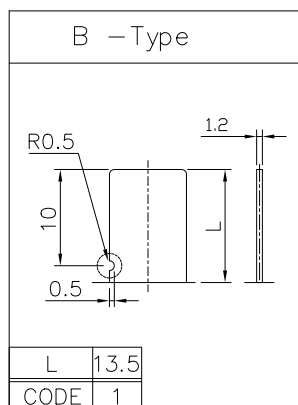

<sup>2</sup> Contact our customer service for custom designs and features.

# Model PS100

## OUTLINE DRAWING

### PS100-1 Single Gang

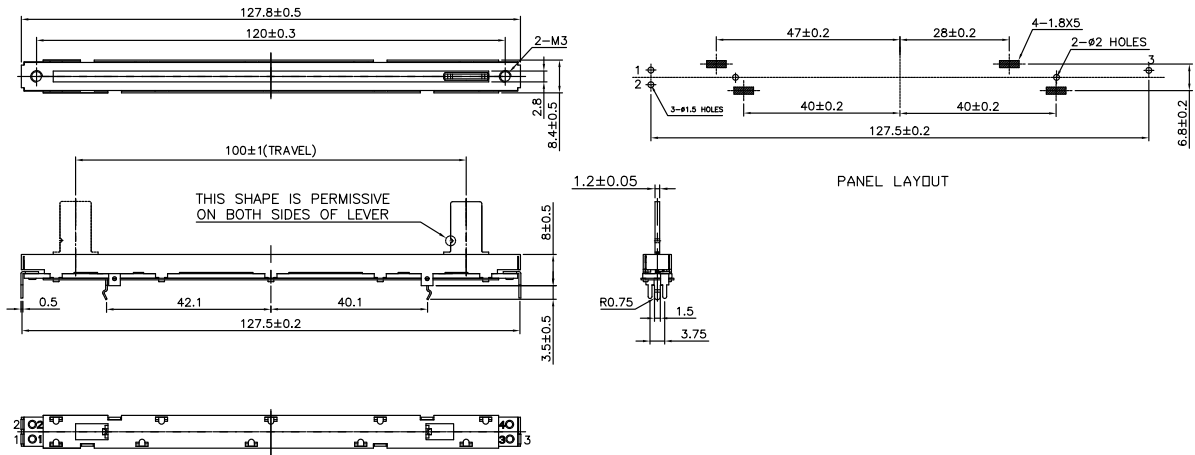

### PS100-2 Dual Gang

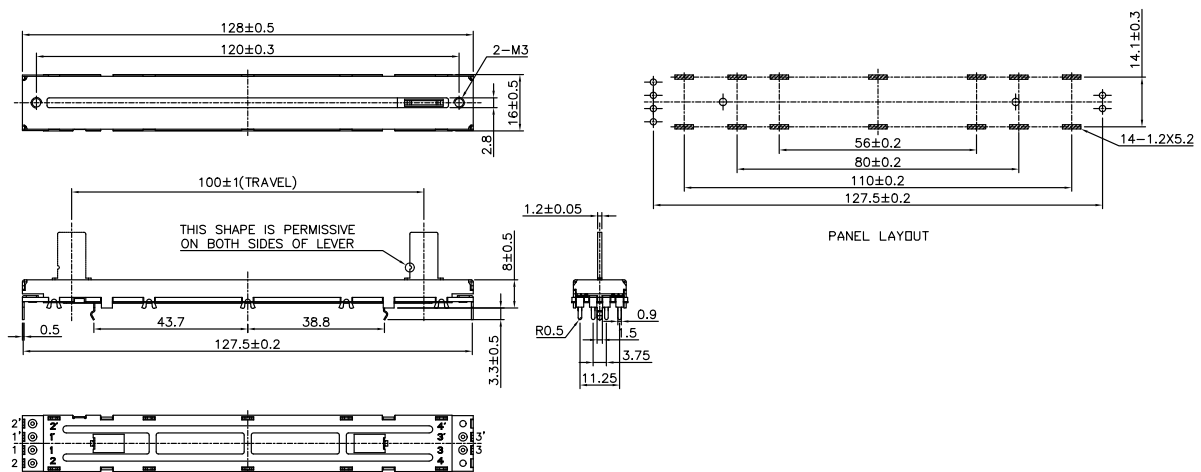

## CIRCUIT DIAGRAM

### PS100-1 Single Gang

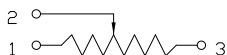

### PS100-2 Dual Gang

