

Excellent Integrated System Limited

Stocking Distributor

Click to view price, real time Inventory, Delivery & Lifecycle Information:

[Vishay/Siliconix](#)
[DG2303DL-T1-E3](#)

For any questions, you can email us directly:

sales@integrated-circuit.com



DG2303

Vishay Siliconix

High-Speed, Low r_{ON} , 1.8-V/2.5-V/3.3-V/5-V, SPST Analog Switch (1-Bit Bus Switch)

DESCRIPTION

The DG2303 is a high-speed, 1-bit, low power, TTL-compatible bus switch. Using sub-micron CMOS technology, DG2303 achieves low on-resistance and negligible propagation delay.

The DG2303 consist of a bi-directional input/output pins A and B. When the output enable (OE) is low, the input/output pins are connected. When the OE is high, the switch is open and a high-impedance state exists between input/output pins A and B.

FEATURES

- SC-70 5-Lead Package
- $5\ \Omega$ Switch Connection Between Two Ports
- Minimal Propagation Delay Through The Switch
- Low I_{CC}
- Zero Bounce In Flow-Through Mode
- Control Inputs Compatible with TTL Level



RoHS*
COMPLIANT

FUNCTIONAL BLOCK DIAGRAM AND PIN CONFIGURATION

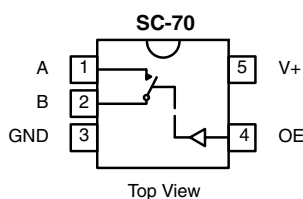

Device Marking: E6

TRUTH TABLE

OE	B	Function
L	HiZ State	Disconnect
H	A	Connect

ORDERING INFORMATION

Temp Range	Package	Part Number
- 40 to 85 °C	SC70-5	DG2303DL-T1 DG2303DL-T1-E3

* Pb containing terminations are not RoHS compliant, exemptions may apply

DG2303

Vishay Siliconix



ABSOLUTE MAXIMUM RATINGS			
Parameter	Limit	Unit	
Reference V+ to GND	- 0.3 to + 6 V	V	
OE, A, B ^a	- 0.3 to (V+ + 0.3 V)		
Continuous Current (Any Terminal)	± 50	mA	
Peak Current (Pulsed at 1 ms, 10 % duty cycle)	± 200		
Storage Temperature (D Suffix)	- 65 to 150	°C	
Power Dissipation (Packages) ^b	5-Pin SC70 ^c	250	mW

Notes:

a. Signals on A, or B or OE exceeding V+ will be clamped by internal diodes. Limit forward diode current to maximum current ratings.

b. All leads welded or soldered to PC Board.

c. Derate 3.1 mW/°C above 70 °C.

SPECIFICATIONS (V+ = 5.0 V)							
Parameter	Symbol	Test Conditions Otherwise Unless Specified V+ = 1.65 V to 5.5 V, V _{IN} = V _{IH} or V _{IL} ^e	Temp ^a	Limits - 40 to 85 °C			Unit
				Min ^b	Typ ^c	Max ^b	
DC Characteristics							
On-Resistance	r _{ON}	V+ = 1.8 V, V _A = 0 V, I _B = 4 mA	Full			28.0	Ω
		V+ = 1.8 V, V _A = 1.8 V, I _B = 4 mA	Full			60.0	
		V+ = 2.3 V, V _A = 0 V, I _B = 8 mA	Full			12.0	
		V+ = 2.3 V, V _A = 2.3 V, I _B = 8 mA	Full			30.0	
		V+ = 3.0 V, V _A = 0 V, I _B = 24 mA	Full			9.0	
		V+ = 3.0 V, V _A = 3.0 V, I _B = 24 mA	Full			20.0	
		V+ = 4.5 V, V _A = 0 V, I _B = 30 mA	Full			7.0	
		V+ = 4.5 V, V _A = 2.4 V, I _B = 15 mA	Full			12.0	
r _{ON} Flatness ^d	r _{ON} Flatness	V+ = 1.8 V, V _A = 0 V to V+, I _B = 4 mA	Full		125		
		V+ = 2.5 V, V _A = 0 V to V+, I _B = 8 mA	Full		28		
		V+ = 3.3 V, V _A = 0 V to V+, I _B = 24 mA	Full		12		
		V+ = 5.0 V, V _A = 0 V to V+, I _B = 30 mA	Full		6		
Switch Off Leakage Current	I _(off)	V+ = 5.5 V, V _A = 1 V/4.5 V, V _B = 4.5 V/1 V	Full	- 10		10	μA
Switch-On Leakage Current	I _(on)	V+ = 5.5 V, V _A = V _B = 1 V/4.5 V	Full	- 10		10	
Input High Voltage	V _{IH}	V+ = 1.65 V to 1.95 V	Full	1.35			V
		V+ = 2.3 V to 2.7 V	Full	1.6			
		V+ = 3.0 V to 3.6 V	Full	2.0			
		V+ = 4.5 V to 5.5 V	Full	2.4			
Input Low Voltage	V _{IL}	V+ = 1.65 V to 1.95 V	Full			0.4	V
		V+ = 2.3 V to 2.7 V	Full			0.4	
		V+ = 3.0 V to 3.6 V	Full			0.6	
		V+ = 4.5 V to 5.5 V	Full			0.8	
Input Current	I _{IL} or I _{IH}	V _{OE} = 0 or V+	Full	- 1		1	μA

DG2303

Vishay Siliconix

SPECIFICATIONS							
Parameter	Symbol	Test Conditions Otherwise Unless Specified $V_+ = 1.65\text{ V to }5.5\text{ V}, V_{IN} = V_{IH}\text{ or }V_{IL}^e$	Temp ^a	Limits - 40 to 85 °C			Unit
				Min ^b	Typ ^c	Max ^b	
Dynamic Characteristics							
Prop Delay Bus-to-Bus ^f	t_{PHL}, t_{PLH}	$V_{LD} = \text{Open}, V = 1.65\text{ V to }1.95\text{ V}$, (Figure 1 and 2)	Full			5	ns
		$V_{LD} = \text{Open}, V = 2.3\text{ V to }2.7\text{ V}$, (Figure 1 and 2)	Full			2	
		$V_{LD} = \text{Open}, V = 3.0\text{ V to }3.6\text{ V}$, (Figure 1 and 2)	Full			1	
		$V_{LD} = \text{Open}, V = 4.5\text{ V to }5.5\text{ V}$, (Figure 1 and 2)	Full			1	
Output Enable Time ^d	t_{PZL}	$V_{LD} = 2 \times V_+, V_+ = 1.65\text{ V to }1.95\text{ V}$ (Figure 1 and 2)	Full		4.2		
		$V_{LD} = 2 \times V_+, V_+ = 2.3\text{ V to }2.7\text{ V}$ (Figure 1 and 2)	Full		3.3		
		$V_{LD} = 2 \times V_+, V_+ = 3.0\text{ V to }3.6\text{ V}$ (Figure 1 and 2)	Full		2.6		
		$V_{LD} = 2 \times V_+, V_+ = 4.5\text{ V to }5.5\text{ V}$ (Figure 1 and 2)	Full		1.8		
	t_{PZH}	$V_{LD} = 0\text{ V}, V_+ = 1.65\text{ V to }1.95\text{ V}$ (Figure 1 and 2)	Full		4.4		
		$V_{LD} = 0\text{ V}, V_+ = 2.3\text{ V to }2.7\text{ V}$ (Figure 1 and 2)	Full		3.3		
		$V_{LD} = 0\text{ V}, V_+ = 3.0\text{ V to }3.6\text{ V}$ (Figure 1 and 2)	Full		2.7		
		$V_{LD} = 0\text{ V}, V_+ = 4.5\text{ V to }5.5\text{ V}$ (Figure 1 and 2)	Full		2.0		
Output Disable Time ^d	t_{PLZ}	$V_{LD} = 2 \times V_+, V_+ = 1.65\text{ V to }1.95\text{ V}$ (Figure 1 and 2)	Full		14.3		
		$V_{LD} = 2 \times V_+, V_+ = 2.3\text{ V to }2.7\text{ V}$ (Figure 1 and 2)	Full		10.5		
		$V_{LD} = 2 \times V_+, V_+ = 3.0\text{ V to }3.6\text{ V}$ (Figure 1 and 2)	Full		8.6		
		$V_{LD} = 2 \times V_+, V_+ = 4.5\text{ V to }5.5\text{ V}$ (Figure 1 and 2)	Full		7.4		
	t_{PHZ}	$V_{LD} = 0\text{ V}, V_+ = 1.65\text{ V to }1.95\text{ V}$ (Figure 1 and 2)	Full		10.7		
		$V_{LD} = 0\text{ V}, V_+ = 2.3\text{ V to }2.7\text{ V}$ (Figure 1 and 2)	Full		9.6		
		$V_{LD} = 0\text{ V}, V_+ = 3.0\text{ V to }3.6\text{ V}$ (Figure 1 and 2)	Full		8.7		
		$V_{LD} = 0\text{ V}, V_+ = 4.5\text{ V to }5.5\text{ V}$ (Figure 1 and 2)	Full		7.5		
Charge Injection ^d	Q_{INJ}	$C_L = 1\text{ nF}, V_{GEN} = 0\text{ V}, R_{GEN} = 0\ \Omega$, (Figure 3)	Room		0.5	pC	
Off Isolation ^d	OIRR	$R_L = 50\ \Omega, C_L = 5\text{ pF}, f = 10\text{ MHz}$	Room		- 50	dB	
Insertion Loss ^d	Loss	$R_L = 50\ \Omega$	Room		> 200	MHz	
Input Capacitance ^d	C_{in}		Room		4	pF	
Channel-Off Capacitance ^d	$C_{(off)}$	$V_{OE} = 0\text{ or }V_+, f = 1\text{ MHz}$	Room		9		
Channel-On Capacitance ^d	C_{ON}		Room		20		
Power Supply							
Power Supply Range	V_+			1.65		5.5	V
Power Supply Current	I_+					1.0	μA

Notes:

- Room = 25 °C, Full = as determined by the operating suffix.
- The algebraic convention whereby the most negative value is a minimum and the most positive a maximum, is used in this data sheet.
- Typical values are for design aid only, not guaranteed nor subject to production testing.
- Guarantee by design, nor subjected to production test.
- V_{IN} = input voltage to perform proper function.
- Guaranteed by design and not production tested. The bus switch propagation delay is a function of the RC time constant contributed by the on-resistance and the specified load capacitance with an ideal voltage source (zero output impedance) driving the switch.

Stresses beyond those listed under "Absolute Maximum Ratings" may cause permanent damage to the device. These are stress ratings only, and functional operation of the device at these or any other conditions beyond those indicated in the operational sections of the specifications is not implied. Exposure to absolute maximum rating conditions for extended periods may affect device reliability.

DG2303

Vishay Siliconix



AC LOADING AND WAVEFORMS

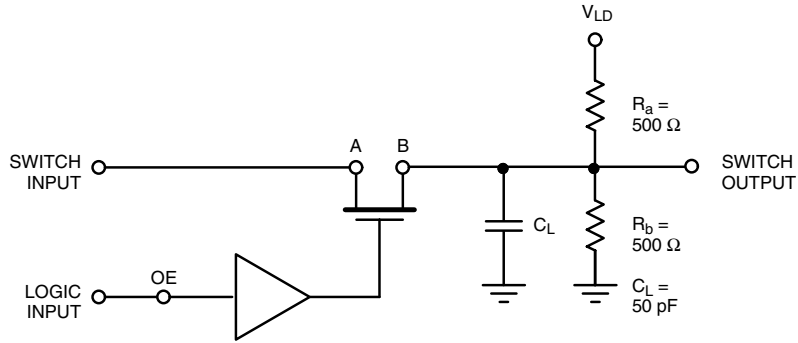

Input driven by 50Ω source terminated in 50Ω
 C_L includes load and stray capacitance
 Input PRR = 1.0 MHz, $t_w = 50 \text{ ns}$

Figure 1. AC Test Circuit

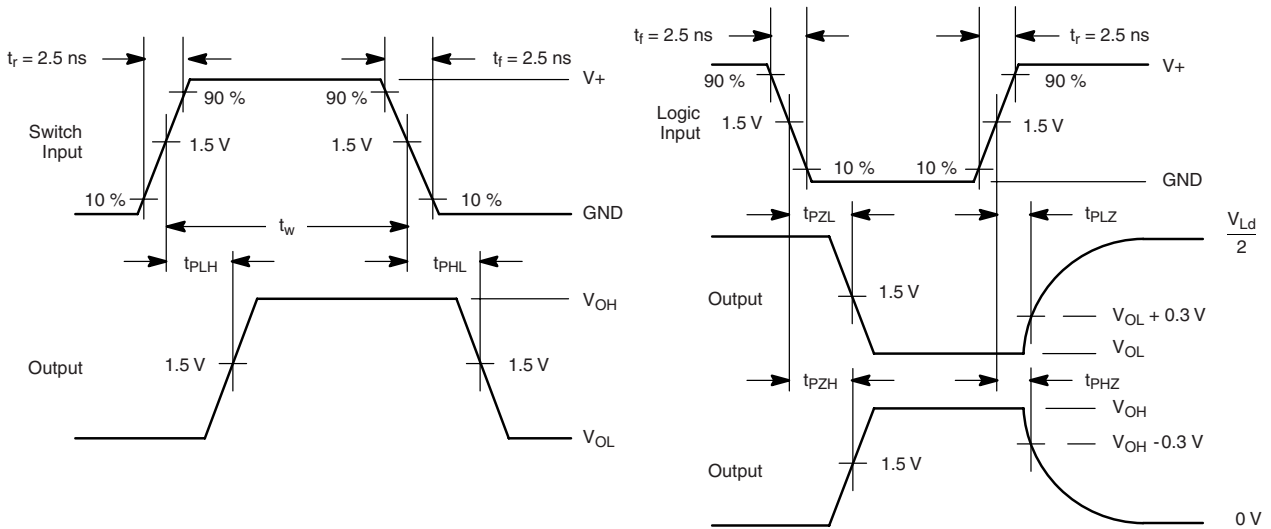

Figure 2. AC Waveforms



DG2303

Vishay Siliconix

TEST CIRCUITS

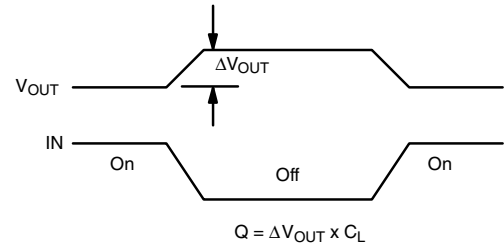
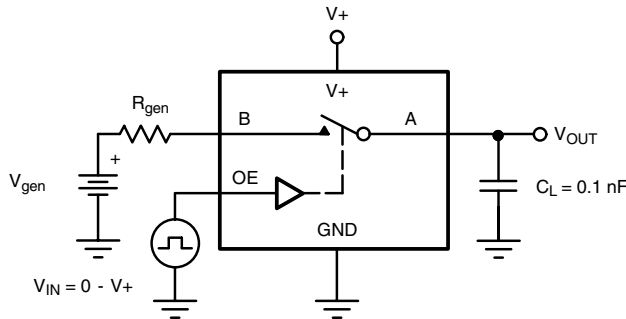

IN depends on switch configuration: input polarity determined by sense of switch.

Figure 3. Charge Injection

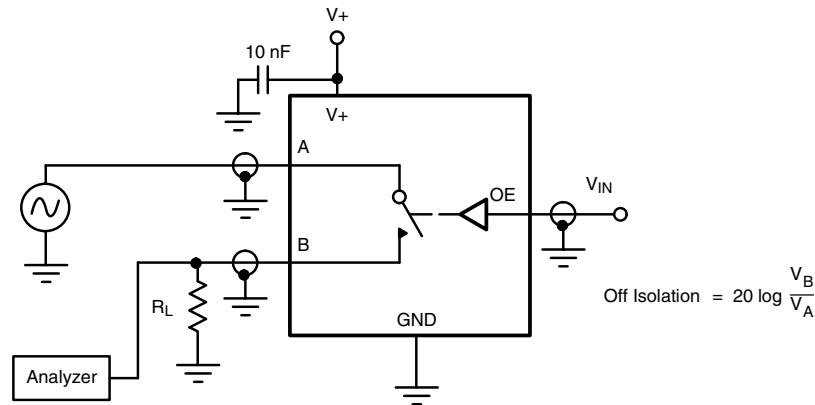

Figure 4. Off-Isolation

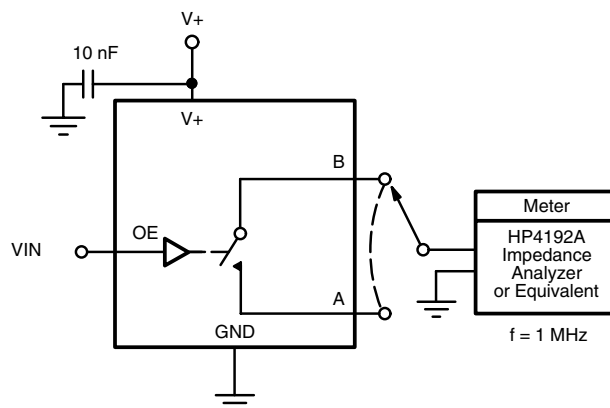

Figure 5. Channel Off/On Capacitance

Vishay Siliconix maintains worldwide manufacturing capability. Products may be manufactured at one of several qualified locations. Reliability data for Silicon Technology and Package Reliability represent a composite of all qualified locations. For related documents such as package/tape drawings, part marking, and reliability data, see <http://www.vishay.com/ppg?72073>.



Legal Disclaimer Notice

Vishay

Disclaimer

All product specifications and data are subject to change without notice.

Vishay Intertechnology, Inc., its affiliates, agents, and employees, and all persons acting on its or their behalf (collectively, "Vishay"), disclaim any and all liability for any errors, inaccuracies or incompleteness contained herein or in any other disclosure relating to any product.

Vishay disclaims any and all liability arising out of the use or application of any product described herein or of any information provided herein to the maximum extent permitted by law. The product specifications do not expand or otherwise modify Vishay's terms and conditions of purchase, including but not limited to the warranty expressed therein, which apply to these products.

No license, express or implied, by estoppel or otherwise, to any intellectual property rights is granted by this document or by any conduct of Vishay.

The products shown herein are not designed for use in medical, life-saving, or life-sustaining applications unless otherwise expressly indicated. Customers using or selling Vishay products not expressly indicated for use in such applications do so entirely at their own risk and agree to fully indemnify Vishay for any damages arising or resulting from such use or sale. Please contact authorized Vishay personnel to obtain written terms and conditions regarding products designed for such applications.

Product names and markings noted herein may be trademarks of their respective owners.