

## **Excellent Integrated System Limited**

Stocking Distributor

Click to view price, real time Inventory, Delivery & Lifecycle Information:

[Omron](#)  
[XY2B-1006](#)

For any questions, you can email us directly:

[sales@integrated-circuit.com](mailto:sales@integrated-circuit.com)

# XG□ Assembly Tooling and Accessories

## Tooling

### ■ XG4 / XG2 - Flat Cable Sockets and Bus Connectors

#### IDC Press

XY2B-0002

IDC Press Tool (Attachments sold separately)

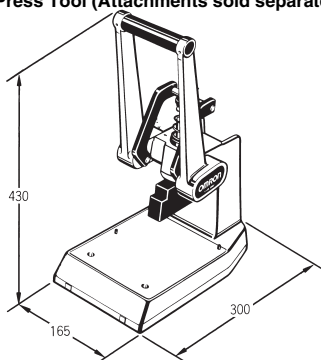

#### IDC Press Attachments for terminating XG4M and XG2A

XY2B-1007

Base attachment for the XG4M

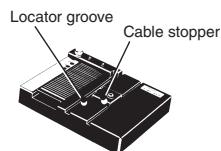

XY2B-1006

Base attachment for the XG2A

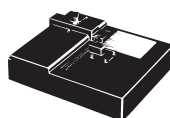

#### Operation

XG4M-series Connectors must be placed face down into the locator slot of the Attachment. (With the XG2A Series, place the terminal block in the Attachment.)

Insert the cable until it is flush against the cable stopper. Connections are made by pulling the handle towards you until it stops. For details on operation, see the user's manual supplied with the IDC Tool.

**Note:** An additional head attachment or spacer is not needed to terminate the XG4M and XG2A connectors.

IDC Press	Base Attachment	Applicable Socket
XY2B-0002	XY2B-1007	XG4M (All contacts)
	XY2B-1006	XG2A (All contacts)

#### IDC Press Attachments for XG4E

XY2B-1004

Base attachment for the XG4E



XY2B-14□□

Spacer for the XG4E (See below)

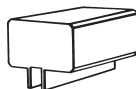

#### Operation

XG4E-series Connectors must be placed face down into the locator slot of the Attachment. Insert the cable until it is flush against the cable stopper.

Next set the proper spacer for the Plug.

Connections are made by pulling the handle towards you until it stops.

IDC Tool	Base Attachment	Spacer	Applicable Plug
XY2B-0002	XY2B-1004	XY2B-1401	XG4E-10□1/-10□2 XG4E-1431/-1432
		XY2B-1402	XG4E-1631/-1632 XG4E-2031/-2032
		XY2B-1403	XG4E-2631/-2632 XG4E-3031/-3032
		XY2B-1404	XG4E-3431/-3432
		XY2B-1405	XG4E-4031/-4032
		XY2B-1406	XG4E-50□1/-50□2
		XY2B-1407	XG4E-60□1/-60□2 XG4E-54□1/-64□2

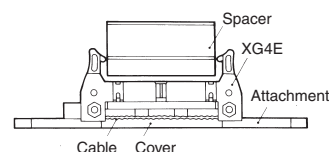

## ■ XG5 - Discrete Wire Sockets

### Manual IDC Termination Tool

XY2B-7006

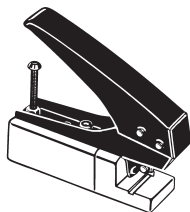

This tool is a compact, light-weight model, ideal for use in the laboratory or for maintenance.

#### Specifications

Applicable connector	XG5M-N
Applicable wire	AWG24 to AWG28 (with an insulation outer diameter of 1.1 to 1.3 mm)
Dimensions	25 (W) × 100 (L) × 80 (H)
Weight	Approx. 180 g

### Automated Wire IDC Tool Set

XY2B-2104-N

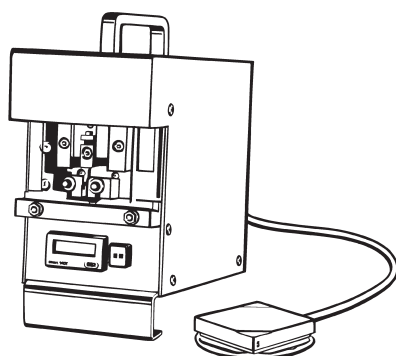

This Wire IDC Tool Set is designed for XG5 Discrete-wire Connectors.

#### Specifications

Stroke	13 mm
Motor speed	83/100 rpm (50/60 Hz)
Feed pitch	2.54 mm
Operation	Foot switch
Weight	About 6 kg
Rated voltage	0.5 A, 100 VAC (50/60 Hz)
Fuse	1 A
Dimensions	120 × 200 × 225 mm (W × H × D)

**Note:** For function and operation details, see the user's manual for the Pressure Welder provided separately.

### Contact Removal Tool

XY2E-0001

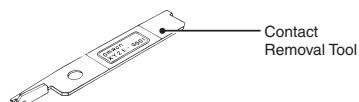

Used to remove contacts, which need to be replaced or reconfigured, from the housing.

#### Replacing Contacts

Use only this tool to remove incorrect IDC contacts.

1. Remove the cover.
2. Insert the tool into the housing lance holes and push the lance into the housing.
3. Pull out the contact while holding the lance down.
4. Insert a new contact.

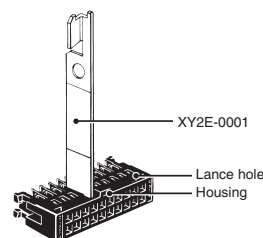

### Applicable Connectors and Wires

Applicable Connector	Size No.	Applicable wires			
		UL file No.	Size [No. of wires/diameter] (mm)	Cross-sectional area (mm)	Covering diameter (mm)
XG5M-□□31-N XG5M-□□32-N XG5M-□□33-N	No. 1	UL1061	AWG24 [7/0.203]	0.21	1.10
XG5M-□□34-N XG5M-□□35-N XG5M-□□36-N	No. 2	UL1007	AWG26 [7/0.16]	0.13	1.30
			AWG28 [7/0.127]	0.09	1.22

**Note:** Use only wires specified in the table above

## Accessories - XG4 / XG5 / XG8

### External Polarization Options

The following optional accessories can be used to provide polarization to sockets and plugs that do not have molded polarizing guides and slots built into their housings and shrouds.

#### Solutions for Shrouded Connectors

##### XG4Z-0004 Polarizing Key

Typically, 10 contact versions of the XG4A, XG4E and XG4C are available with or without polarizing guides.

Install the XG4Z-0004 polarizing key on XG4A pcb sockets, XG4E plugs and XG4C pcb sockets that do not have a polarizing slot, to prevent reverse connection with XG4M cable sockets that do not have a polarizing guide.

For all other versions, the molded polarity guides and slots can be used by themselves to help prevent reverse insertion. However, use the polarizing key with these versions as well for best results.

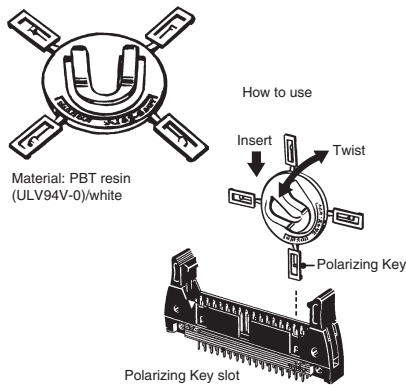

**Note:** Each XG4Z-0004 has 4 Polarizing Keys.

#### Solutions for Unshrouded Connectors

Use the XG4Z-0005 coding pin to fill a specific hole in one of the XG4 or XG5 sockets. Then, use the XY2E-0002 cutting pin to remove the corresponding terminal from an XG8 unshrouded plug. (See XG5 and XG8 datasheets for details about those connectors.)

##### XG4Z-0005 Coding Pin

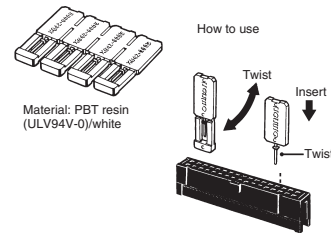

**Note:** 1. A contact with a Coding Pin inserted cannot be used.  
 2. Each XG4Z-0005 has 4 Polarizing Keys.

##### XY2E-0002 Contact Cutting Driver

The Contact Cutting Driver is used to cut (twist off) a contact on the mating Plug when using an XG4Z-0005 Coding Pin.

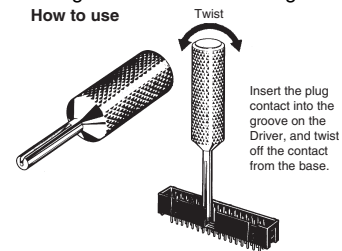

### Top Lock Levers

#### XG5Z-0002 - "Lock Lever"

Use to lock right angle XG8B and XG8W Plugs to mating sockets

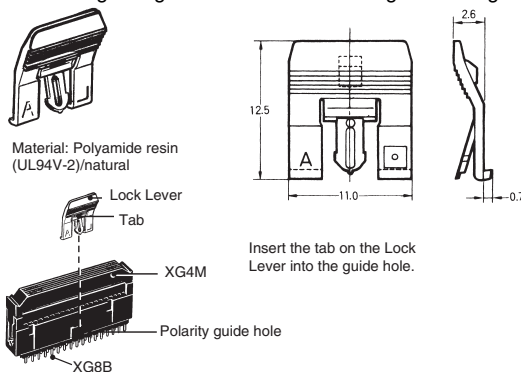

#### XG4Z-0002 - "Lock Lever II"

Use to lock XG4C Box-type Plugs to mating sockets.

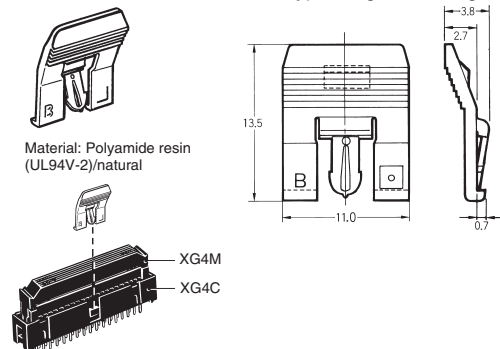

### XG5 - Spare Contacts

#### XG5W-0031-N (Size #1)

#### XG5W-0034-N (Size #2)

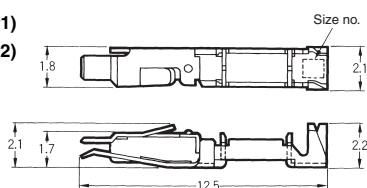

Model	Order in Multiples of
XG5W-0031-N	100
XG5W-0034-N	

**Note:** 1. These Contacts can be used as replacements if a wrong connection is made.  
 2. The applicable wire for size No. 1 is AWG24 (UL-1061). The applicable wire for size No. 2 is AWG26 to AWG28 (UL-1007).

All sales are subject to Omron Electronic Components LLC standard terms and conditions of sale, which can be found at [http://www.components.omron.com/components/web/webfiles.nsf/sales\\_terms.html](http://www.components.omron.com/components/web/webfiles.nsf/sales_terms.html)

**ALL DIMENSIONS SHOWN ARE IN MILLIMETERS.**

To convert millimeters into inches, multiply by 0.03937. To convert grams into ounces, multiply by 0.03527.

**OMRON**<sup>®</sup>

**OMRON ELECTRONIC  
COMPONENTS LLC**

55 E. Commerce Drive, Suite B  
Schaumburg, IL 60173

**847-882-2288**

**OMRON ON-LINE**

Global - <http://www.omron.com>

USA - <http://www.components.omron.com>