

Excellent Integrated System Limited

Stocking Distributor

Click to view price, real time Inventory, Delivery & Lifecycle Information:

[Amphenol RF](#)
[112182](#)

For any questions, you can email us directly:

sales@integrated-circuit.com

REV.	DATE	DESCRIPTION
NC	01/04/04	UPDATE DRAWING FORMAT

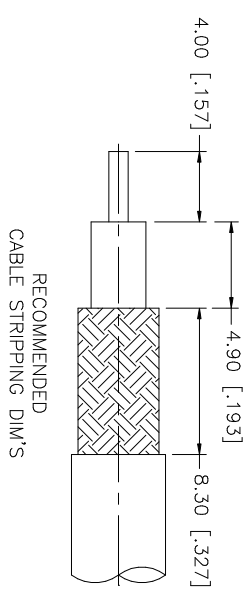
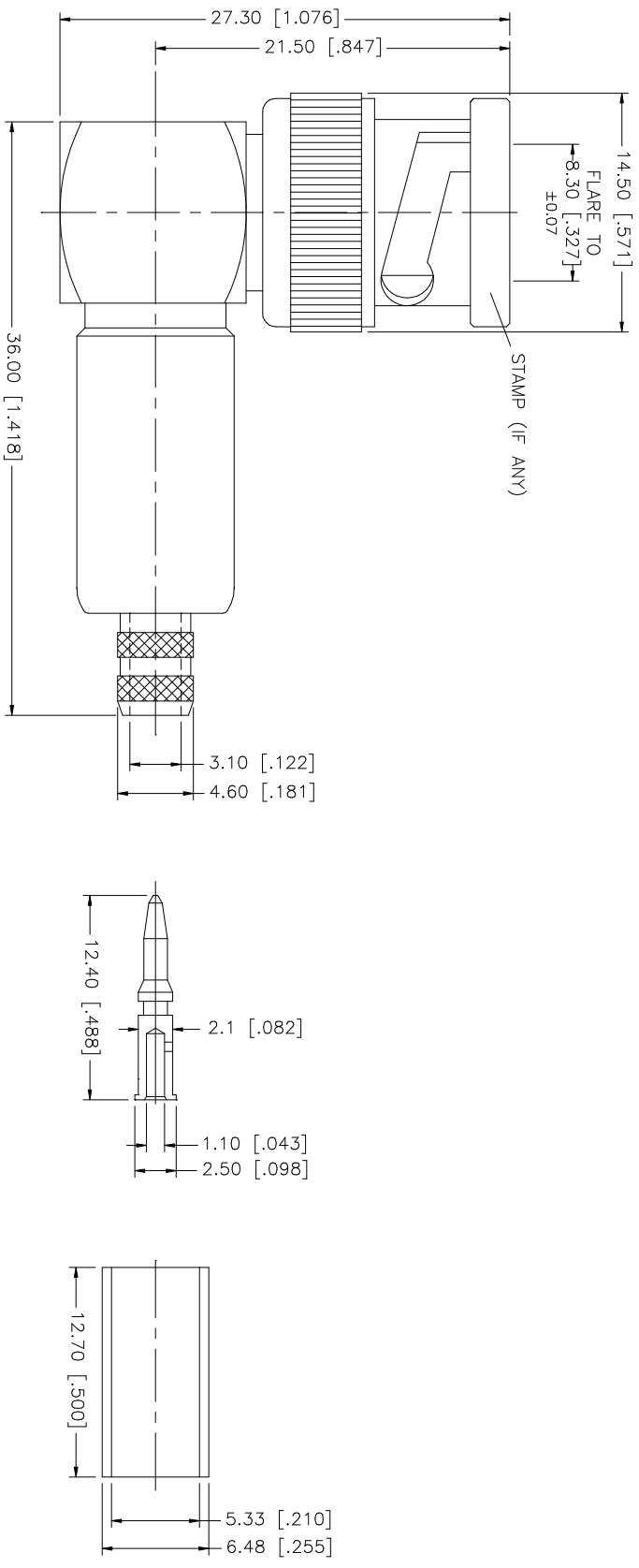

NOTE:
 1. CRIMPED FERRULE
 HEX CRIMP SIZE .213"
 2. CRIMPED CONTACT PIN
 HEX CRIMP SIZE .068"

QTY	DESCRIPTION	MATERIAL	FINISH
1	BODY	BRASS	NICKEL
2	INSULATOR	DELRIN	NATURAL
2	CONTACT PIN	BRASS	GOLD
1	CONTACT PIN	PHOS. BRONZE	GOLD
1	FERRULE	COPPER	NICKEL

UNLESS OTHERWISE SPECIFIED DIMENSIONS ARE IN MILLIMETERS (INCHES) UNLESS OTHERWISE SPECIFIED	UNLESS OTHERWISE SPECIFIED DIMENSIONS ARE IN INCHES (MILLIMETERS) UNLESS OTHERWISE SPECIFIED
TOLERANCES FOR MILLIMETERS ARE: 0.5 - 8mm ± 0.20mm 8 - 30mm ± 0.40mm 30 - 120mm ± 0.50mm	TOLERANCES FOR INCHES ARE: .020 - .315 = ± 0.007" .315 - 1.180 = ± 0.015" 1.180 - 4.724 = ± 0.020"

APPROVALS	DATE
DRAWN G.R.S.	01/04/04
CHECKED	
ISSUED	
SHEET 1 OF 1	

PART NO.	PART DESCRIPTION	DWG. NO.	REV.	NC	SIZE	SCALE
112182	BNC R/A CRIMP PLUG (FOR RG-58/U, 141/U CABLE)	112182.DWG			A	NA