

Excellent Integrated System Limited

Stocking Distributor

Click to view price, real time Inventory, Delivery & Lifecycle Information:

[Amphenol RE](#)
[APH-SMAJ-TNCP](#)

For any questions, you can email us directly:

sales@integrated-circuit.com

NOTES:

1. MATERIALS AND FINISHES:

BODY - BRASS (ASTM-B16 H02, C36000), NICKEL PLATING
 CONTACT PIN - PHOSPHOR BRONZE, GOLD PLATING
 INSULATOR - PTFE PER ASTM D 1710 OR EQUIV.

2. ELECTRICAL:

A. IMPEDANCE: 50 OHM
 B. FREQUENCY RANGE: DC - 11 GHz

3. MECHANICAL:

A. TEMPERATURE RANGE: -65° C TO +165° C

4. PACKAGING:

A. QUANTITY: SINGLE PACK
 B. MARKING: BAG TO BE MARKED
 AMPHENOL, APH-SMAJ-TNCP, AND DATE CODE

APH-SMAJ-TNCP		REVISIONS			
DRAWING NO.	REV	DESCRIPTION	DATE	ECO	APPR
THIRD ANGLE PROJ.	A	RELEASE TO MFG.	9/15/06	46271	CPM/

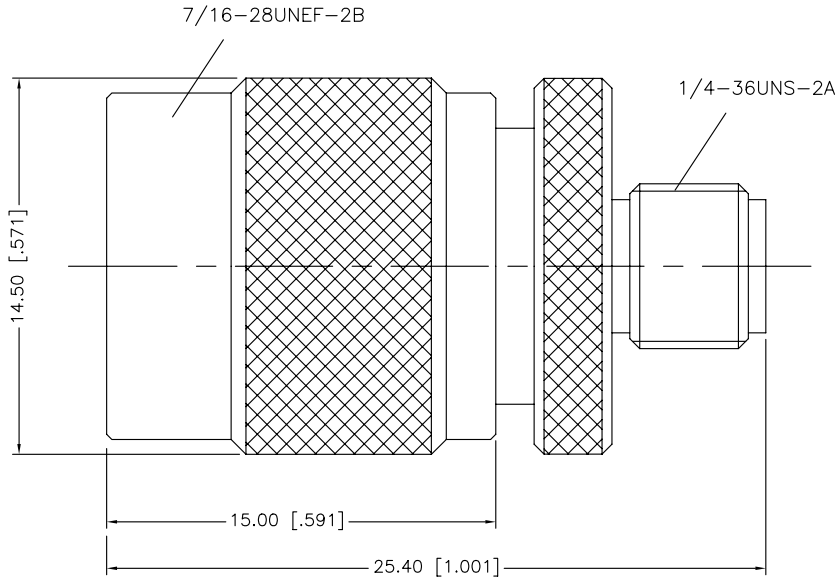

UNLESS OTHERWISE SPECIFIED, DIMENSIONS ARE IN INCHES AND TOLERANCES ARE:
 2 PLACE DECIMAL ±.015 (0,381 mm) 3 PLACE DECIMAL ±.005 (0,127 mm) ANGLES ± 1°

NOTICE - These drawings, specifications, or other data (1) are, and remain the property of Amphenol Corp. (2) must be returned upon request; and (3) are confidential and not to be disclosed to any person other than those to whom they are given by Amphenol Corp. The furnishing of these drawings, specifications, or other data by Amphenol Corp., or to any other person to anyone for any purpose is not to be regarded by implication or otherwise in any manner licensing, granting rights or permitting such holder or any other person to manufacture, use or sell any product, process or design, patented or otherwise, that may in any way be related to or disclosed by said drawings, specifications, or other data.

MATERIAL	DRAWN	C. McGRATH	DATE	8/21/06	TITLE	SMA FEMALE TO TNC MALE ADAPTER	Amphenol Amphenol Corporation RF/Microwave Operations Danbury, Conn. U.S.A. 06810								
	ENGINEER	O. BARTHELMES	DATE	8/21/06											
	APPROVED	O. BARTHELMES	DATE	9/15/06											
REFERENCE	CAD FILE H:\DEPT611\ASSY\APH\SMAJ-TNCP				CODE ID	74868	DWG SIZE	B	DRAWING NO.	APH-SMAJ-TNCP	SCALE: 2:1	SHEET	OF	ISSUE	A