

Excellent Integrated System Limited

Stocking Distributor

Click to view price, real time Inventory, Delivery & Lifecycle Information:

[ON Semiconductor](#)
[SRDA3.3-4DR2G](#)

For any questions, you can email us directly:

sales@integrated-circuit.com

SRDA3.3-4

Low Capacitance Surface Mount TVS for High-Speed Data Interfaces

The SRDA3.3-4 transient voltage suppressor is designed to protect equipment attached to high speed communication lines from ESD and lightning.

Features

- Protects 4 I/O Lines
- Low Working Voltage: 3.3 V
- Low Clamping Voltage
- Low Capacitance (<15 pF) for High Speed Interfaces
- Peak Power – 500 W 8x20 μs
- Transient Protection for High Speed Lines to:
 - IEC61000-4-2 (ESD) ±15 kV (air), ±8 kV (contact)
 - IEC61000-4-4 (EFT) 40 A
 - IEC61000-4-5 (Lightning) 25 A
- UL Flammability Rating of 94 V-0
- This is a Pb-Free Device

Typical Applications

- High Speed Communication Line Protection
- T1/E1 Secondary Protection
- T3/E3 Secondary Protection
- Analog Video Protection
- Base Stations
- I²C Bus Protection

MAXIMUM RATINGS

Rating	Symbol	Value	Unit
Peak Power Dissipation 8 x 20 μs @ T _A = 25°C (Note 1)	P _{pk}	500	W
Junction and Storage Temperature Range	T _J , T _{stg}	-55 to +150	°C
Lead Solder Temperature – Maximum 10 Seconds Duration	T _L	260	°C
IEC 61000-4-2	Contact Air	ESD ±8 ±15	kV
IEC 61000-4-4 (5/50 ns)	EFT	40	A
IEC 61000-4-5 (8 x 20 μs)	-	25	A

Stresses exceeding Maximum Ratings may damage the device. Maximum Ratings are stress ratings only. Functional operation above the Recommended Operating Conditions is not implied. Extended exposure to stresses above the Recommended Operating Conditions may affect device reliability.

1. Non-repetitive current pulse 8 x 20 μs exponential decay waveform Pin 2/3 to Pin 5/8



ON Semiconductor®

http://onsemi.com

**SO-8 LOW CAPACITANCE
VOLTAGE SUPPRESSOR
500 WATTS PEAK POWER
3.3 VOLTS**

PIN CONFIGURATION AND SCHEMATIC

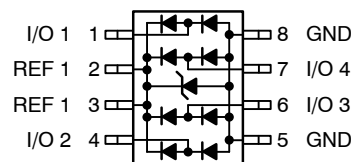

SOIC-8
CASE 751
PLASTIC

MARKING DIAGRAM

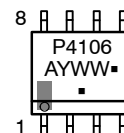

- A = Assembly Location
- Y = Year
- WW = Work Week
- = Pb-Free Package

(Note: Microdot may be in either location)

ORDERING INFORMATION

Device	Package	Shipping†
SRDA3.3-4DR2G	SO-8 (Pb-Free)	2500/Tape & Reel

†For information on tape and reel specifications, including part orientation and tape sizes, please refer to our Tape and Reel Packaging Specification Brochure, BRD8011/D.

SRDA3.3-4

ELECTRICAL CHARACTERISTICS

Characteristic	Symbol	Min	Typ	Max	Unit
Reverse Stand-Off Voltage	V_{RWM}	-	-	3.3	V
Reverse Breakdown Voltage @ $I_T = 1.0$ mA	V_{BR}	5.0	-	-	V
Reverse Leakage Current @ $V_{RWN} = 3.3$ V	I_R	N/A	2.8	5.0	μ A
Maximum Clamping Voltage @ $I_{PP} = 1.0$ A, 8×20 μ S	V_C	N/A	5.9	7.0	V
Maximum Clamping Voltage @ $I_{PP} = 10$ A, 8×20 μ S	V_C	N/A	7.1	10	V
Maximum Clamping Voltage @ $I_{PP} = 25$ A, 8×20 μ S	V_C	N/A	9.0	15	V
Between I/O Pins and Ground @ $V_R = 0$ V, 1.0 MHz	C_J	-	8.0	15	pF
Between I/O Pins @ $V_R = 0$ Volts, 1.0 MHz	C_J	-	4.0	-	pF

ELECTRICAL CHARACTERISTICS

($T_A = 25^\circ$ C unless otherwise noted)

Symbol	Parameter
I_{PP}	Maximum Reverse Peak Pulse Current
V_C	Clamping Voltage @ I_{PP}
V_{RWM}	Working Peak Reverse Voltage
I_R	Maximum Reverse Leakage Current @ V_{RWM}
V_{BR}	Breakdown Voltage @ I_T
I_T	Test Current
I_F	Forward Current
V_F	Forward Voltage @ I_F
P_{pk}	Peak Power Dissipation
C	Capacitance @ $V_R = 0$ and $f = 1.0$ MHz

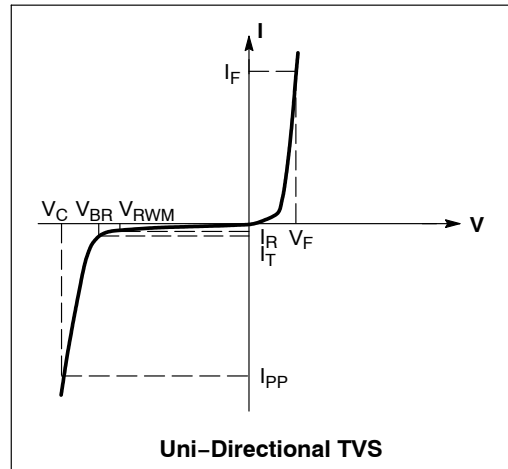

*See Application Note AND8308/D for detailed explanations of datasheet parameters.

TYPICAL CHARACTERISTICS

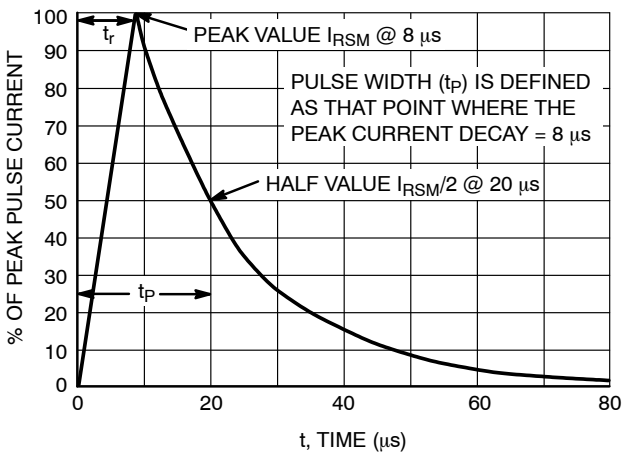

Figure 1. 8×20 μ s Pulse Waveform

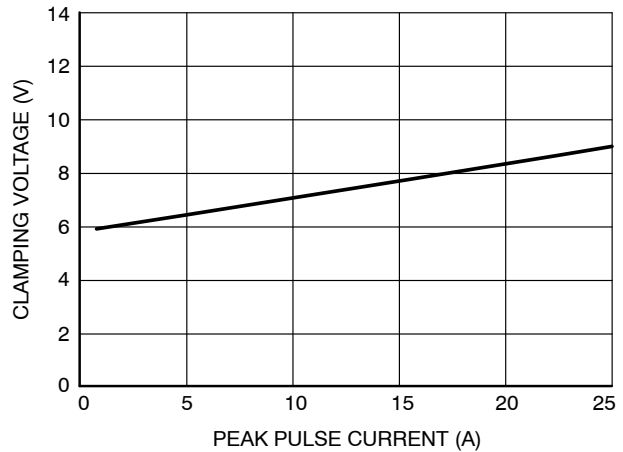

Figure 2. Clamping Voltage vs. Peak Pulse Current (8×20 μ s Waveform)

SRDA3.3-4

APPLICATIONS INFORMATION

The SRDA3.3-4 is a low capacitance TVS diode array designed to protect sensitive electronics such as communications systems, computers, and computer peripherals against damage due to ESD events or transient overvoltage conditions. Because of its low capacitance, it can be used in high speed I/O data lines. The integrated design of the SRDA3.3-4 offers surge rated, low capacitance steering diodes and a TVS diode integrated in a single package (SO-8). If a transient condition occurs, the steering diodes will drive the transient to the positive rail of the power supply or to ground. The TVS device protects the power line against overvoltage conditions avoiding damage to the power supply and other downstream components.

SRDA3.3-4 Configuration Options

The SRDA3.3-4 is able to protect up to four data lines against transient overvoltage conditions by driving them to a fixed reference point for clamping purposes. The steering diodes will be forward biased whenever the voltage on the protected line exceeds the reference voltage (V_f or $V_{CC} + V_f$). The diodes will force the transient current to bypass the sensitive circuit.

Data lines are connected at pins 1, 4, 6 and 7. The negative reference is connected at pins 5 and 8. These pins must be connected directly to ground using a ground plane to minimize the PCB's ground inductance. It is very important to reduce the PCB trace lengths as much as possible to minimize parasitic inductances.

Option 1

Protection of four data lines and the power supply using V_{CC} as reference.

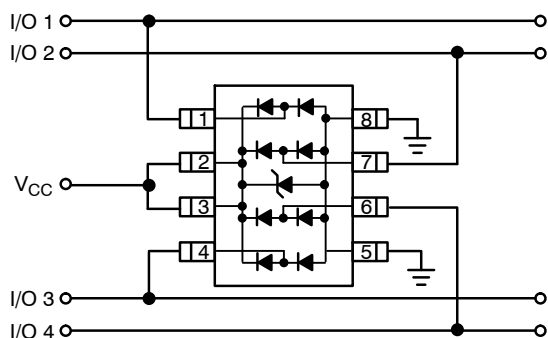

Figure 3.

For this configuration, connect pins 2 and 3 directly to the positive supply rail (V_{CC}). The data lines are referenced to the supply voltage. The internal TVS diode prevents overvoltage on the supply rail. Biasing of the steering diodes reduces their capacitance.

Option 2

Protection of four data lines with bias and power supply isolation resistor.

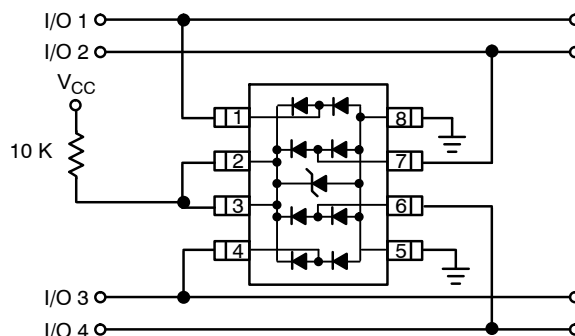

Figure 4.

The SRDA3.3-4 can be isolated from the power supply by connecting a series resistor between pins 2 and 3 and V_{CC} . A 10 k Ω resistor is recommended for this application. This will maintain a bias on the internal TVS and steering diodes, reducing their capacitance.

Option 3

Protection of four data lines using the internal TVS diode as reference.

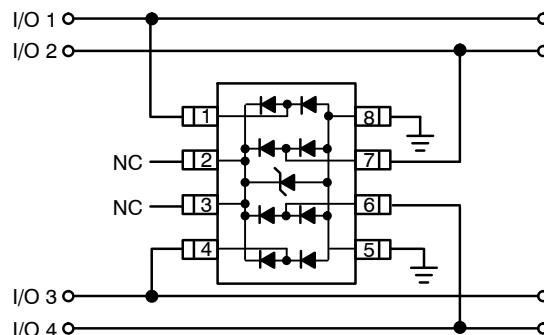

Figure 5.

In applications lacking a positive supply reference or those cases in which a fully isolated power supply is required, the internal TVS can be used as the reference. For these applications, pins 2 and 3 are not connected. In this configuration, the steering diodes will conduct whenever the voltage on the protected line exceeds the working voltage of the TVS plus one diode drop ($V_c = V_f + V_{TVS}$).

SRDA3.3-4

ESD Protection of Power Supply Lines

When using diodes for data line protection, referencing to a supply rail provides advantages. Biasing the diodes reduces their capacitance and minimizes signal distortion. Implementing this topology with discrete devices does have disadvantages. This configuration is shown below:

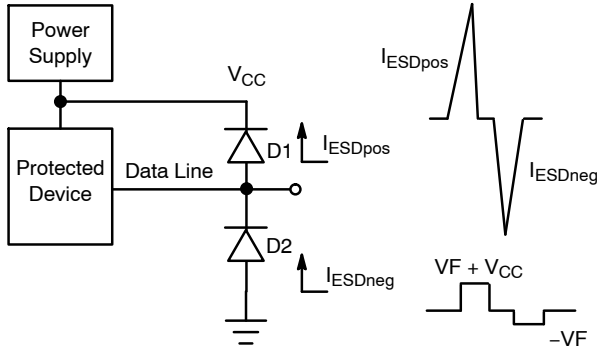

Figure 6.

Looking at the figure above, it can be seen that when a positive ESD condition occurs, diode D1 will be forward biased while diode D2 will be forward biased when a negative ESD condition occurs. For slower transient conditions, this system may be approximated as follows:

For positive pulse conditions:

$$V_c = V_{CC} + V_{fD1}$$

For negative pulse conditions:

$$V_c = -V_{fD2}$$

ESD events can have rise times on the order of some number of nanoseconds. Under these conditions, the effect of parasitic inductance must be considered. A pictorial representation of this is shown below.

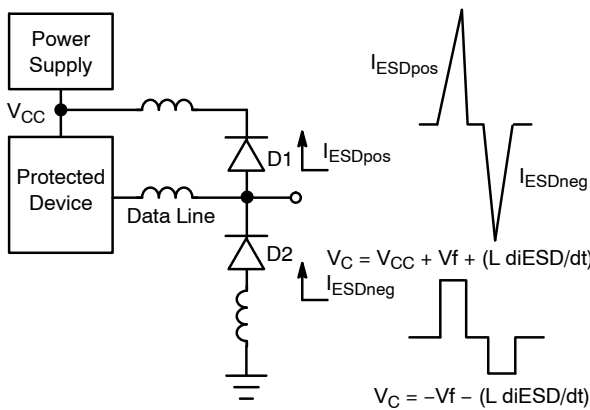

Figure 7.

An approximation of the clamping voltage for these fast transients would be:

For positive pulse conditions:

$$V_c = V_{CC} + V_f + (L \, di_{ESD}/dt)$$

For negative pulse conditions:

$$V_c = -V_f - (L \, di_{ESD}/dt)$$

As shown in the formulas, the clamping voltage (V_c) not only depends on the V_f of the steering diodes but also on the

$L \, di_{ESD}/dt$ factor. A relatively small trace inductance can result in hundreds of volts appearing on the supply rail. This endangers both the power supply and anything attached to that rail. This highlights the importance of good board layout. Taking care to minimize the effects of parasitic inductance will provide significant benefits in transient immunity.

Even with good board layout, some disadvantages are still present when discrete diodes are used to suppress ESD events across datalines and the supply rail. Discrete diodes with good transient power capability will have larger die and therefore higher capacitance. This capacitance becomes problematic as transmission frequencies increase. Reducing capacitance generally requires reducing die size. These small die will have higher forward voltage characteristics at typical ESD transient current levels. This voltage combined with the smaller die can result in device failure.

The ON Semiconductor SRDA3.3-4 was developed to overcome the disadvantages encountered when using discrete diodes for ESD protection. This device integrates a TVS diode within a network of steering diodes.

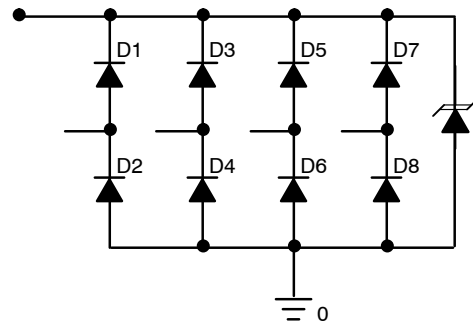

Figure 8. SRDA3.3-4 Equivalent Circuit

During an ESD condition, the ESD current will be driven to ground through the TVS diode as shown below.

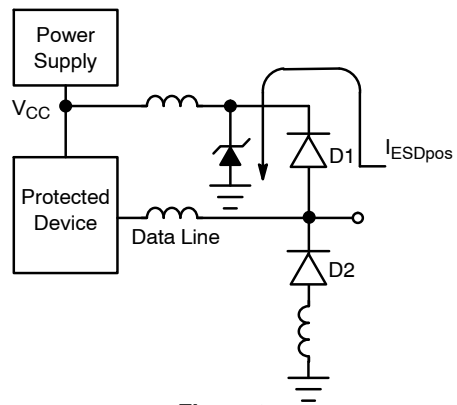

Figure 9.

The resulting clamping voltage on the protected IC will be:

$$V_c = V_{fD1} + V_{TVS}$$

The clamping voltage of the TVS diode is provided in Figure 2 and depends on the magnitude of the ESD current. The steering diodes are fast switching devices with unique forward voltage and low capacitance characteristics.

SRDA3.3-4

TYPICAL APPLICATIONS

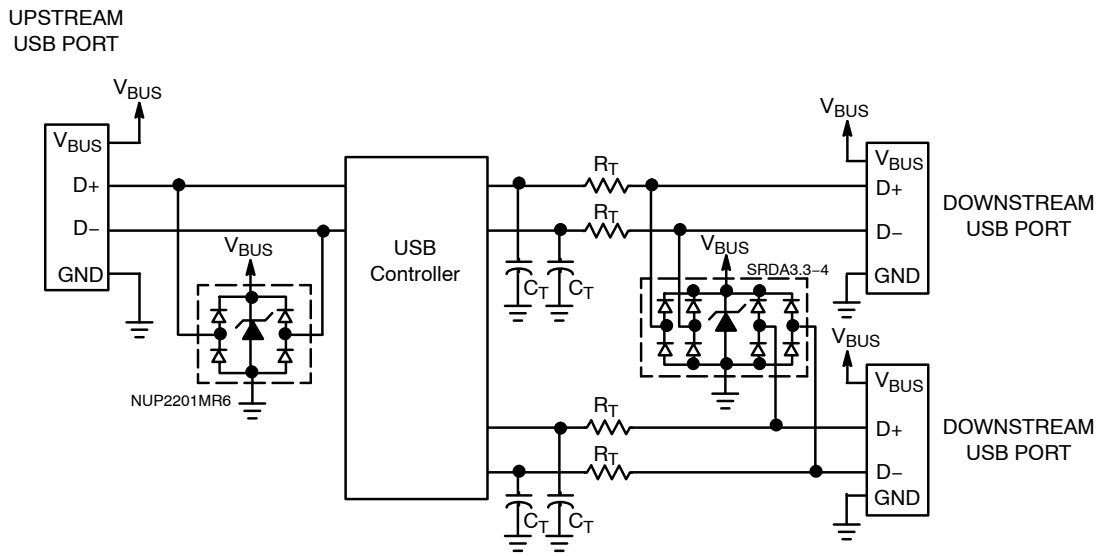

Figure 10. ESD Protection for USB Port

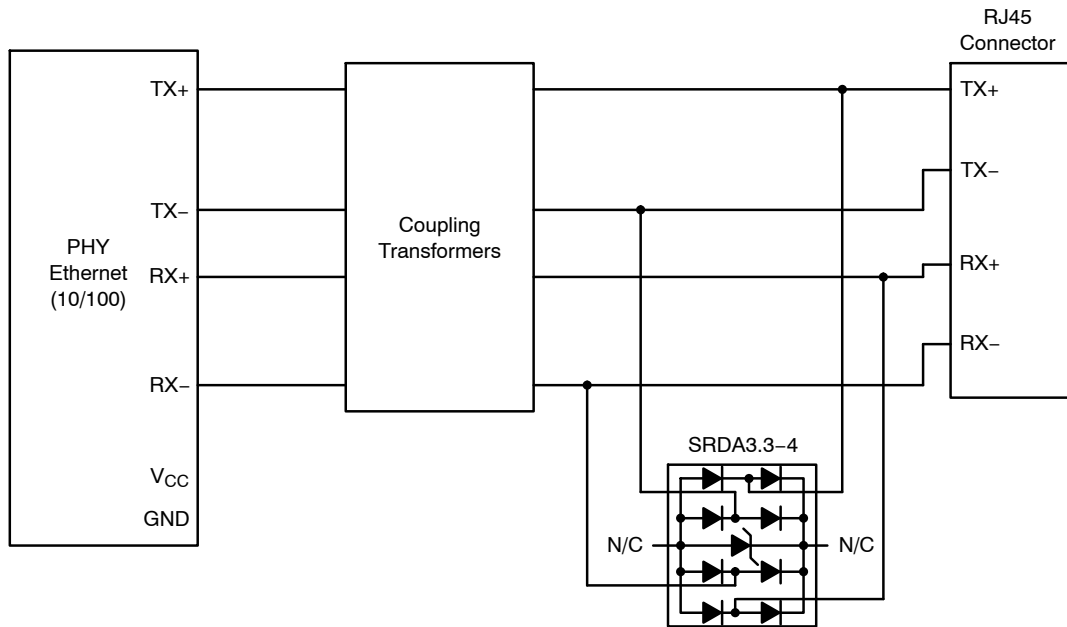

Figure 11. Protection for Ethernet 10/100 (Differential Mode)

SRDA3.3-4

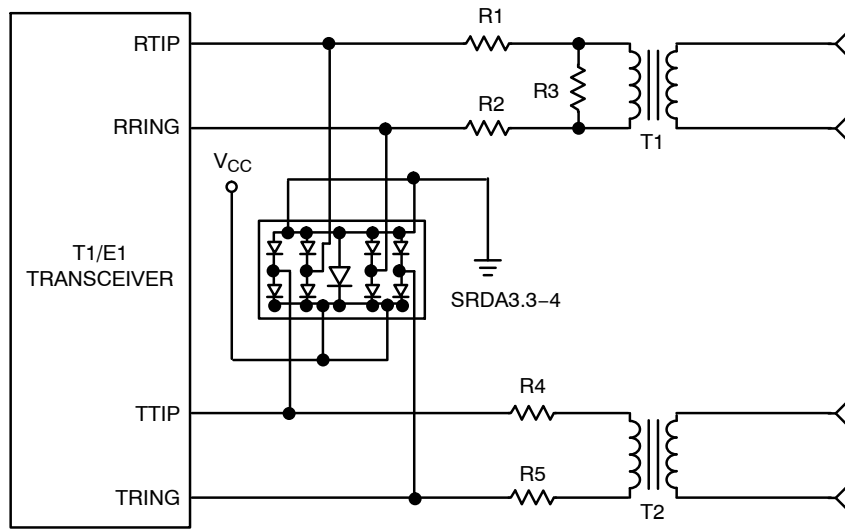
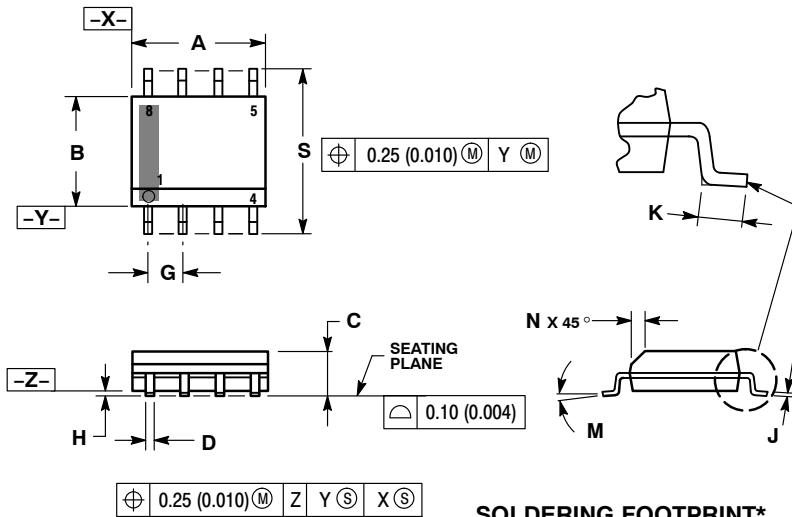

Figure 12. T1/E1 Interface Protection

SRDA3.3-4

PACKAGE DIMENSIONS

SOIC-8 NB
CASE 751-07
ISSUE AJ



NOTES:

1. DIMENSIONING AND TOLERANCING PER ANSI Y14.5M, 1982.
2. CONTROLLING DIMENSION: MILLIMETER.
3. DIMENSION A AND B DO NOT INCLUDE MOLD PROTRUSION.
4. MAXIMUM MOLD PROTRUSION 0.15 (0.006) PER SIDE.
5. DIMENSION D DOES NOT INCLUDE DAMBAR PROTRUSION. ALLOWABLE DAMBAR PROTRUSION SHALL BE 0.127 (0.005) TOTAL IN EXCESS OF THE D DIMENSION AT MAXIMUM MATERIAL CONDITION.
6. 751-01 THRU 751-06 ARE OBSOLETE. NEW STANDARD IS 751-07.

DIM	MILLIMETERS		INCHES	
	MIN	MAX	MIN	MAX
A	4.80	5.00	0.189	0.197
B	3.80	4.00	0.150	0.157
C	1.35	1.75	0.053	0.069
D	0.33	0.51	0.013	0.020
G	1.27 BSC		0.050 BSC	
H	0.10	0.25	0.004	0.010
J	0.19	0.25	0.007	0.010
K	0.40	1.27	0.016	0.050
M	0°	8°	0°	8°
N	0.25	0.50	0.010	0.020
S	5.80	6.20	0.228	0.244

SOLDERING FOOTPRINT*

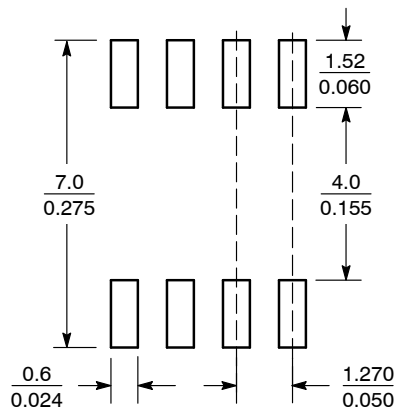

SCALE 6:1 (mm/inches)

*For additional information on our Pb-Free strategy and soldering details, please download the ON Semiconductor Soldering and Mounting Techniques Reference Manual, SOLDERRM/D.

ON Semiconductor and are registered trademarks of Semiconductor Components Industries, LLC (SCILLC). SCILLC reserves the right to make changes without further notice to any products herein. SCILLC makes no warranty, representation or guarantee regarding the suitability of its products for any particular purpose, nor does SCILLC assume any liability arising out of the application or use of any product or circuit, and specifically disclaims any and all liability, including without limitation special, consequential or incidental damages. "Typical" parameters which may be provided in SCILLC data sheets and/or specifications can and do vary in different applications and actual performance may vary over time. All operating parameters, including "Typicals" must be validated for each customer application by customer's technical experts. SCILLC does not convey any license under its patent rights nor the rights of others. SCILLC products are not designed, intended, or authorized for use as components in systems intended for surgical implant into the body, or other applications intended to support or sustain life, or for any other application in which the failure of the SCILLC product could create a situation where personal injury or death may occur. Should Buyer purchase or use SCILLC products for any such unintended or unauthorized application, Buyer shall indemnify and hold SCILLC and its officers, employees, subsidiaries, affiliates, and distributors harmless against all claims, costs, damages, and expenses, and reasonable attorney fees arising out of, directly or indirectly, any claim of personal injury or death associated with such unintended or unauthorized use, even if such claim alleges that SCILLC was negligent regarding the design or manufacture of the part. SCILLC is an Equal Opportunity/Affirmative Action Employer. This literature is subject to all applicable copyright laws and is not for resale in any manner.

PUBLICATION ORDERING INFORMATION

LITERATURE FULFILLMENT:

Literature Distribution Center for ON Semiconductor
 P.O. Box 5163, Denver, Colorado 80217 USA
 Phone: 303-675-2175 or 800-344-3860 Toll Free USA/Canada
 Fax: 303-675-2176 or 800-344-3867 Toll Free USA/Canada
 Email: orderlit@onsemi.com

N. American Technical Support: 800-282-9855 Toll Free USA/Canada

Europe, Middle East and Africa Technical Support:
 Phone: 421 33 790 2910

Japan Customer Focus Center
 Phone: 81-3-5773-3850

ON Semiconductor Website: www.onsemi.com

Order Literature: <http://www.onsemi.com/orderlit>

For additional information, please contact your local Sales Representative