

Excellent Integrated System Limited

Stocking Distributor

Click to view price, real time Inventory, Delivery & Lifecycle Information:

[Everlight Electronics Co Ltd](#)
[PT958-8C](#)

For any questions, you can email us directly:

sales@integrated-circuit.com



LIGHTING FOREVER

Technical Data Sheet

1.6mm Side Looking Phototransistor

PT958-8C

Features

- Fast response time
- High sensitivity
- Small junction capacitance
- Pb free
- This product itself will remain within RoHS compliant version.

Descriptions

The PT958-8C is a phototransistor in miniature package which is molded in a clear plastic with spherical top view lens.

The device is spectrally matched to infrared emitting diode.

Applications

- Optoelectronic switch
- VCR , Video Camera
- Floppy disk drive
- Infrared applied system

Device Selection Guide

LED Part No.	Chip	Lens Color
	Material	
PT958-8C	Silicon	Clear



PT958-8C

Package Dimensions

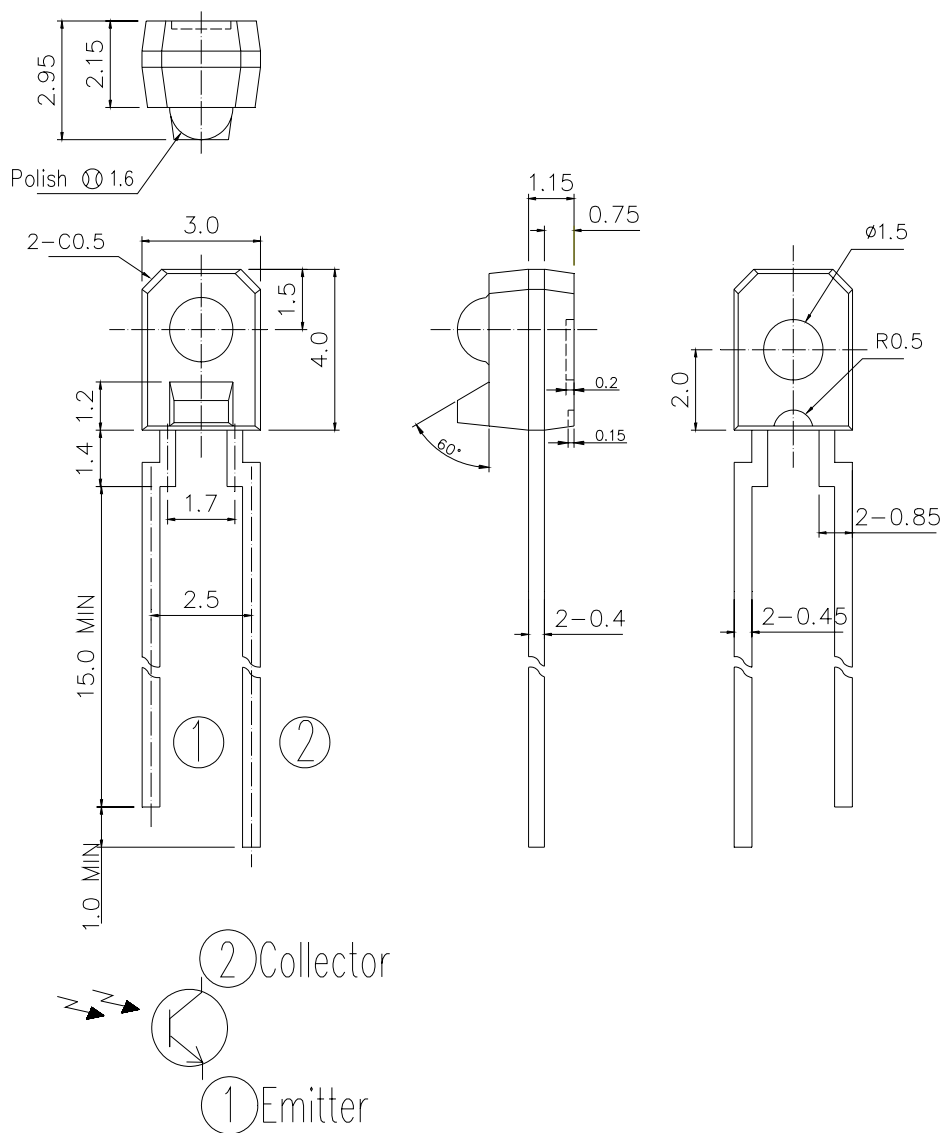

- Notes:** 1.All dimensions are in millimeters
 2.Tolerances unless dimensions $\pm 0.25\text{mm}$



PT958-8C

Absolute Maximum Ratings (Ta=25°C)

Parameter	Symbol	Rating	Units
Collector-Emitter Voltage	V _{CEO}	30	V
Emitter-Collector-Voltage	V _{ECO}	5	V
Collector Current	I _C	20	mA
Operating Temperature	T _{opr}	-25 ~ +85	°C
Storage Temperature	T _{stg}	-40 ~ +100	°C
Lead Soldering Temperature(*1)	T _{sol}	260	°C
Power Dissipation at (or below) 25°C Free Air Temperature	P _d	75	mW

Notes: *1:Soldering time ≤ 5 seconds.

Electro-Optical Characteristics (Ta=25°C)

Parameter	Symbol	Condition	Min.	Typ.	Max.	Units
Collector – Emitter Breakdown Voltage	BV _{CEO}	I _C =100 μA Ee=0mW/cm ²	30	---	---	V
Emitter-Collector Breakdown Voltage	BV _{ECO}	I _E =100 μA Ee=0mW/cm ²	5	---	---	V
Collector-Emitter Saturation Voltage	V _{(CE)(sat)}	I _C =2mA Ee=1mW/cm ²	---	---	0.4	V
Rise Time	t _r	V _{CE} =5V I _C =1mA	---	15	---	μS
Fall Time	t _f	RL=1000Ω	---	15	---	
Collector Dark Current	I _{CEO}	Ee=0mW/cm ² V _{CE} =20V	---	---	100	nA
On State Collector Current	I _{C(on)}	Ee=0.555mW/cm ² V _{CE} =5V	0.53	---	3.41	mA
Wavelength of Peak Sensitivity	λ _p	---	---	940	---	nm
Rang of Spectral Bandwidth	λ _{0.5}	---	400	---	1100	nm



PT958-8C

Typical Electro-Optical Characteristics Curves

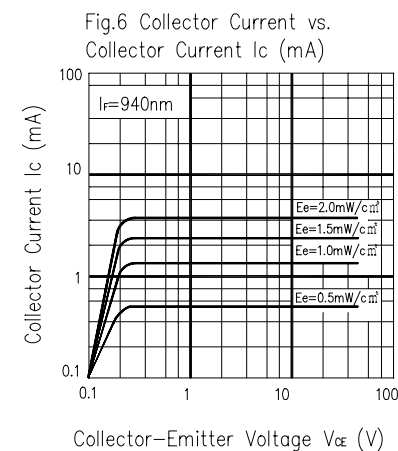
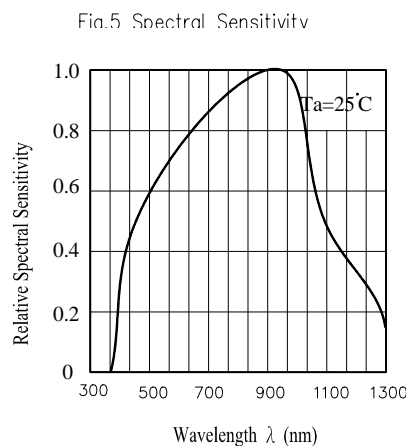
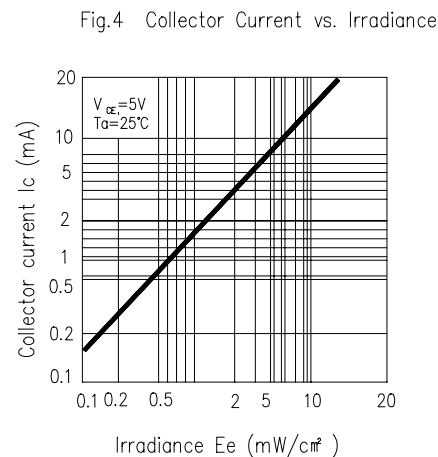
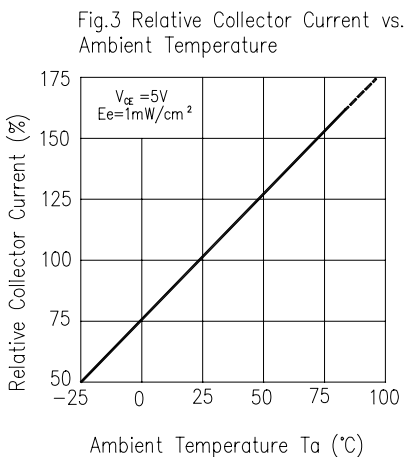
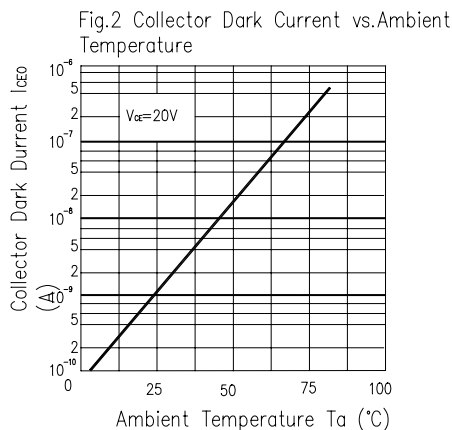
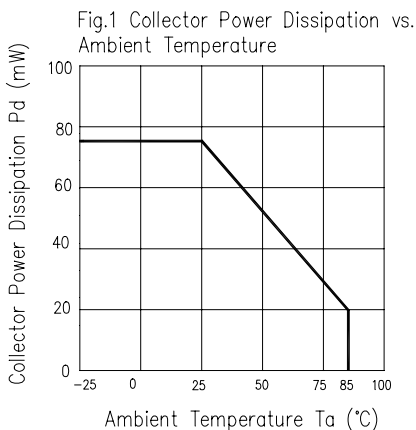



PT958-8C

Test method

Light current test method for PT:

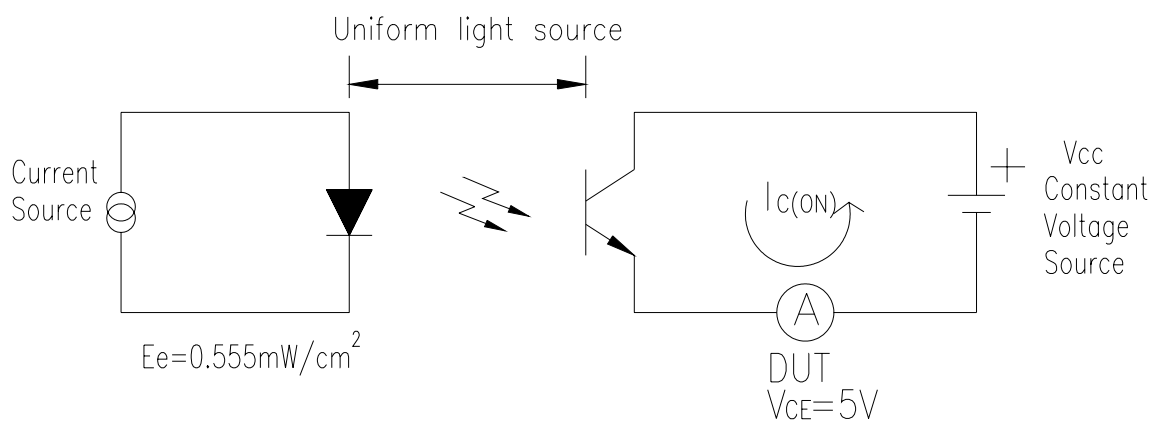

Ranks

Parameter	Symbol	Min	Max	Unit	Test condition
7-3	$I_{C(ON)}$	0.53	1.19	mA	$V_{CE}=5V$ $E_e=0.555mW/cm^2$
7-2		0.88	1.70		
7-1		1.24	2.21		
6-2		1.59	2.98		
6-1		1.77	3.41		



PT958-8C

Reliability Test Item And Condition

The reliability of products shall be satisfied with items listed below.

Confidence level : 90%

LTPD : 10%

NO.	Item	Test Conditions	Test Hours/ Cycles	Sample Sizes	Failure Judgement Criteria	Ac/Re
1	Solder Heat	TEMP:260°C±5°C	10sec	22pcs	Attenuation of Light Current value>20%	0/1
2	Temperature Cycle	H : +100°C 15mins ↕ 5mins L : -40°C 15mins	300Cycle	22pcs		0/1
3	Thermal Shock	H :+100°C 5mins ↕ 10secs L :-10°C 5mins	300Cycle	22pcs		0/1
4	High Temperature Storage	TEMP. : +100°C	1000hrs	22pcs		0/1
5	Low Temperature Storage	TEMP. : -40°C	1000hrs	22pcs		0/1
6	DC Operating Life	V _{CE} =5V	1000hrs	22pcs		0/1
7	High Temperature/ High Humidity	85°C / 85% R.H	1000hrs	22pcs		0/1



PT958-8C

Packing Quantity Specification

1. 1000 Pcs/1Bag , 8 Bags/1Box
2. 10 Boxes/1Carton

Label Form Specification

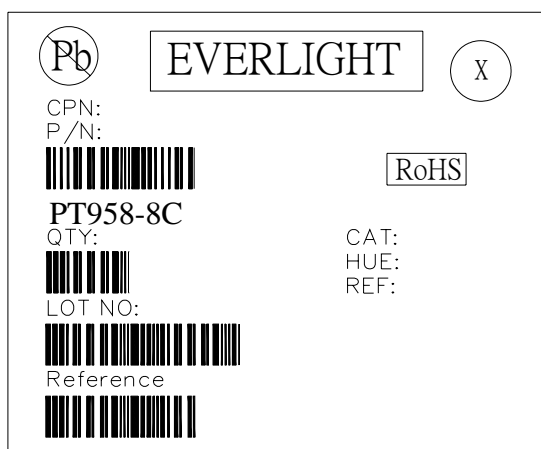

- CPN: Customer's Production Number
- P/N : Production Number
- QTY: Packing Quantity
- CAT: Ranks
- HUE: Peak Wavelength
- REF: Reference
- LOT No: Lot Number
- X: Month
- Reference: Identify Label Number

Notes

1. Above specification may be changed without notice. EVERLIGHT will reserve authority on material change for above specification.
2. When using this product, please observe the absolute maximum ratings and the instructions for using outlined in these specification sheets. EVERLIGHT assumes no responsibility for any damage resulting from use of the product which does not comply with the absolute maximum ratings and the instructions included in these specification sheets.
3. These specification sheets include materials protected under copyright of EVERLIGHT corporation. Please don't reproduce or cause anyone to reproduce them without EVERLIGHT's consent.

EVERLIGHT ELECTRONICS CO., LTD. Office: No 25, Lane 76, Sec 3, Chung Yang Rd, Tucheng, Taipei 236, Taiwan, R.O.C	Tel: 886-2-2267-2000, 2267-9936 Fax: 886-2267-6244, 2267-6189, 2267-6306 http://www.everlight.com
---	--