

Excellent Integrated System Limited

Stocking Distributor

Click to view price, real time Inventory, Delivery & Lifecycle Information:

[STMicroelectronics](#)
[STA516B13TR](#)

For any questions, you can email us directly:

sales@integrated-circuit.com



STA516B

65 V, 7.5 A quad power half bridge

Datasheet - production data

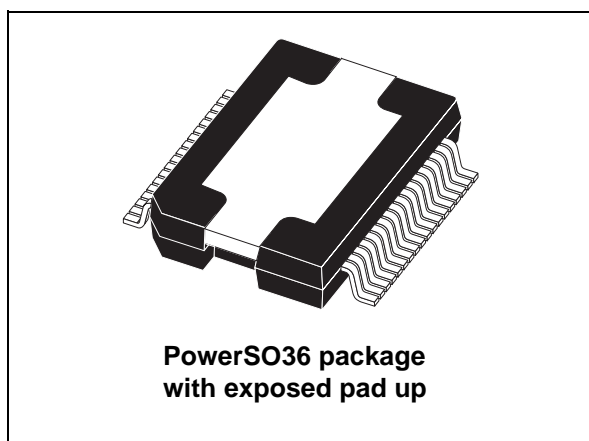

Description

STA516B is a monolithic quad half-bridge stage in multipower BCD technology. The device can be used as dual bridge or reconfigured, by connecting pin CONFIG to pins VDD, as a single bridge with double-current capability or as a half bridge (binary mode) with half current capability.

The device is designed, particularly, to be the output stage of a stereo all digital high efficiency amplifier. It is capable of delivering 200 W + 200 W into 6 Ω loads with THD = 10% at $V_{CC} = 51$ V or, in single BTL configuration, 400 W into a 3 Ω load with THD = 10% at $V_{CC} = 52$ V.

The input pins have a threshold proportional to the voltage on pin VL.

The STA516B is aimed at audio amplifiers in hi-fi applications, such as home theatre systems, active speakers and docking stations.

It comes in a 36 pin PowerSO package with exposed pad up (EPU).

Features

- Low input/output pulse width distortion
- 200 mΩ R_{dsON} complementary DMOS output stage
- CMOS compatible logic inputs
- Thermal protection
- Thermal warning output
- Undervoltage protection

Table 1. Device summary

Order code	Temperature range	Package	Packaging
STA516B13TR	0 to 90 °C	PowerSO36 EPU	Tape and reel

1 Introduction

Figure 1. Application circuit (dual BTL)

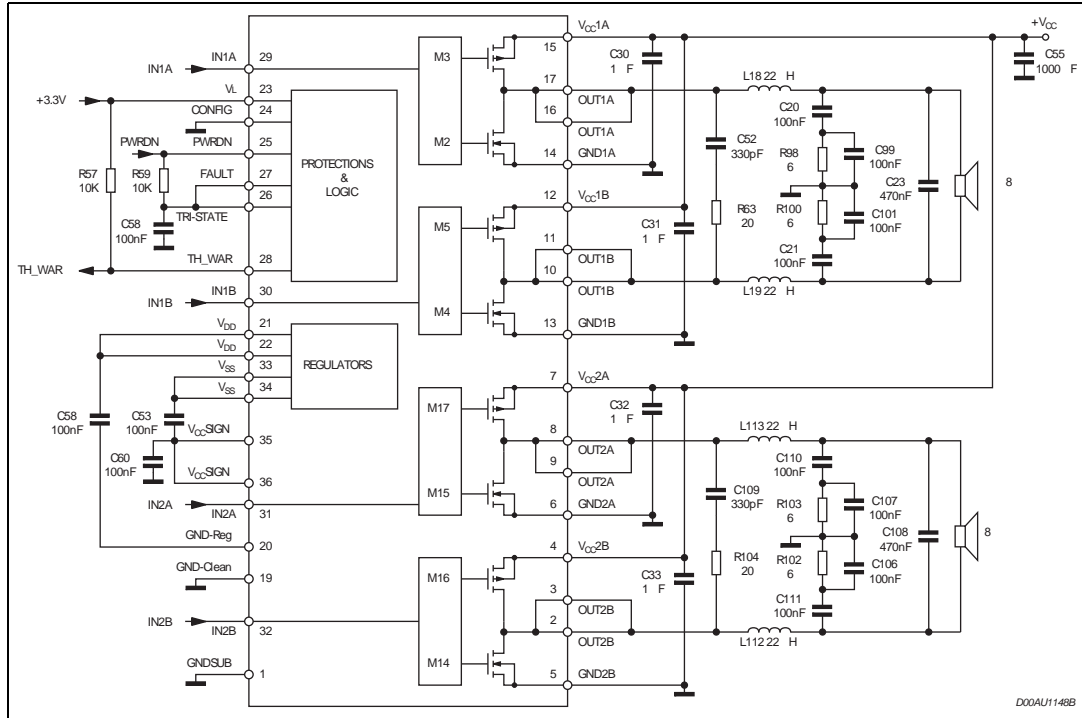

D00AU1148B

2 Pin description

Figure 2. Pin out

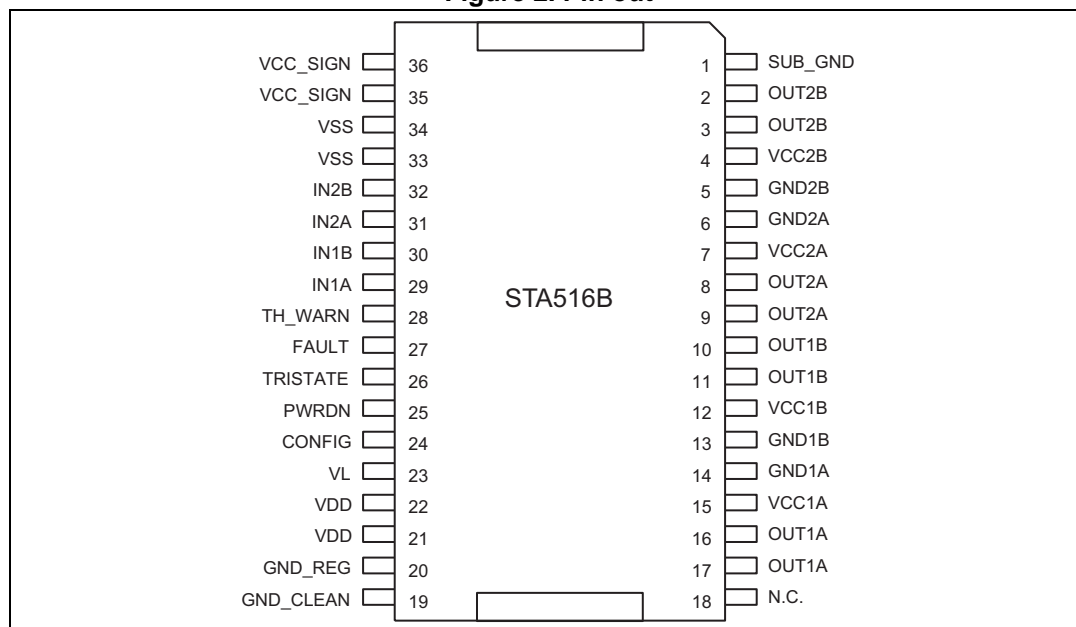

Table 2. Pin function

Pin	Name	Type	Description
1	GND_SUB	PWR	Substrate ground
2, 3	OUT2B	O	Output half bridge 2B
4	VCC2B	PWR	Positive supply
5	GND2B	PWR	Negative supply
6	GND2A	PWR	Negative supply
7	VCC2A	PWR	Positive supply
8, 9	OUT2A	O	Output half bridge 2A
10, 11	OUT1B	O	Output half bridge 1B
12	VCC1B	PWR	Positive supply
13	GND1B	PWR	Negative supply
14	GND1A	PWR	Negative supply
15	VCC1A	PWR	Positive supply
16, 17	OUT1A	O	Output half bridge 1A
18	N.C.	-	No internal connection
19	GND_CLEAN	PWR	Logical ground
20	GND_REG	PWR	Ground for regulator V_{DD}
21, 22	VDD	PWR	5-V regulator referred to ground
23	VL	PWR	High logical state setting voltage, V_L

Pin description

STA516B

Table 2. Pin function (continued)

Pin	Name	Type	Description
24	CONFIG	I	Configuration pin: 0: normal operation 1: bridges in parallel (OUT1A = OUT1B, OUT2A = OUT2B (if IN1A = IN1B, IN2A = IN2B))
25	PWRDN	I	Standby pin: 0: low-power mode 1: normal operation
26	TRISTATE	I	Hi-Z pin: 0: all power amplifier outputs in high impedance state 1: normal operation
27	FAULT	O	Fault pin advisor (open-drain device, needs pull-up resistor): 0: fault detected (short circuit or thermal, for example) 1: normal operation
28	TH_WARN	O	Thermal warning advisor (open-drain device, needs pull-up resistor): 0: temperature of the IC >130 °C 1: normal operation
29	IN1A	I	Input of half bridge 1A
30	IN1B	I	Input of half bridge 1B
31	IN2A	I	Input of half bridge 2A
32	IN2B	I	Input of half bridge 2B
33, 34	VSS	PWR	5-V regulator referred to +V _{CC}
35, 36	VCC_SIGN	PWR	Signal positive supply

3 Electrical characteristics

Table 3. Absolute maximum ratings

Symbol	Parameter	Value	Unit
V _{CC_MAX}	DC supply voltage (pins 4, 7, 12, 15)	65	V
V _{max}	Maximum voltage on pins 23 to 32	5.5	V
T _{j_MAX}	Operating junction temperature	0 to 150	°C
T _{stg}	Storage temperature	-40 to 150	°C

Warning: Stresses beyond those listed under “Absolute maximum ratings” make cause permanent damage to the device. These are stress ratings only, and functional operation of the device at these or any other conditions beyond those indicated under “Recommended operating condition” are not implied. Exposure to absolute-maximum-rated conditions for extended periods may affect device reliability. In the real application, power supply with nominal value rated inside recommended operating conditions, may experience some rising beyond the maximum operating condition for short time when no or very low current is sinked (amplifier in mute state). In this case the reliability of the device is guaranteed, provided that the absolute maximum rating is not exceeded.

Table 4. Thermal data

Symbol	Parameter	Min.	Typ.	Max.	Unit
T _{j-case}	Thermal resistance junction to case (thermal pad)	-	1	2.5	°C/W
T _{warn}	Thermal warning temperature	-	130	-	°C
T _{jSD}	Thermal shut-down junction temperature	-	150	-	°C
t _{hSD}	Thermal shut-down hysteresis	-	25	-	°C

Table 5. Recommended operating conditions

Symbol	Parameter	Min.	Typ.	Max.	Unit
V _{CC}	Supply voltage for pins PVCCA, PVCCB	10	-	58	V
T _{amb}	Ambient operating temperature	0	-	90	°C

Electrical characteristics

STA516B

Unless otherwise stated, the test conditions for [Table 6](#) below are $V_L = 3.3\text{ V}$, $V_{CC} = 50\text{ V}$ and $T_{amb} = 25\text{ }^\circ\text{C}$

Table 6. Electrical characteristics

Symbol	Parameter	Test conditions	Min.	Typ.	Max.	Unit
R_{dsON}	Power P-channel/N-channel MOSFET R_{dsON}	$I_{dd} = 1\text{ A}$	-	200	240	m Ω
I_{dss}	Power P-channel/N-channel leakage I_{dss}	-	-	-	50	μA
g_N	Power P-channel R_{dsON} matching	$I_{dd} = 1\text{ A}$	95	-	-	%
g_P	Power N-channel R_{dsON} matching	$I_{dd} = 1\text{ A}$	95	-	-	%
Dt_s	Low current dead time (static)	see Figure 3	-	10	20	ns
Dt_d	High current dead time (dynamic)	$L = 22\text{ }\mu\text{H}$, $C = 470\text{ nF}$ $R_L = 8\text{ }\Omega$, $I_{dd} = 4.5\text{ A}$ see Figure 4	-	-	50	ns
t_{dON}	Turn-on delay time	Resistive load	-	-	100	ns
t_{dOFF}	Turn-off delay time	Resistive load	-	-	100	ns
t_r	Rise time	Resistive load see Figure 3	-	-	25	ns
t_f	Fall time	Resistive load see Figure 3	-	-	25	ns
$V_{IN-High}$	High level input voltage	-	-	-	$V_L/2 + 300\text{ mV}$	V
V_{IN-Low}	Low level input voltage	-	$V_L/2 - 300\text{ mV}$	-	-	V
I_{IN-H}	High level input current	$V_{IN} = V_L$	-	1	-	μA
I_{IN-L}	Low level input current	$V_{IN} = 0.3\text{ V}$	-	1	-	μA
$I_{PWRDN-H}$	High level PWRDN pin input current	$V_L = 3.3\text{ V}$	-	35	-	μA
V_{Low}	Low logical state voltage (pins PWRDN, TRISTATE) (see Table 7)	$V_L = 3.3\text{ V}$	0.8	-	-	V
V_{High}	High logical state voltage (pins PWRDN, TRISTATE) (see Table 7)	$V_L = 3.3\text{ V}$	-	-	1.7	V
$I_{VCC-PWRDN}$	Supply current from V_{CC} in power down	$V_{PWRDN} = 0\text{ V}$	-	-	2.4	mA
I_{FAULT}	Output current on pins FAULT, TH_WARN with fault condition	$V_{pin} = 3.3\text{ V}$	-	1	-	mA
$I_{VCC-HiZ}$	Supply current from V_{CC} in tristate	$V_{TRISTATE} = 0\text{ V}$	-	22	-	mA

STA516B

Electrical characteristics

Table 6. Electrical characteristics (continued)

Symbol	Parameter	Test conditions	Min.	Typ.	Max.	Unit
I_{VCC}	Supply current from V_{CC} in operation, both channels switching)	Input pulse width = 50% duty, switching frequency = 384 kHz, no LC filters	-	70	-	mA
I_{OCP}	Overcurrent protection threshold I_{sc} (short-circuit current limit) ⁽¹⁾	-	7.5	8.5	10	A
V_{UVP}	Undervoltage protection threshold	-	-	7	-	V
V_{OVP}	Overvoltage protection threshold	-	61	62.5	-	V
t_{pw_min}	Output minimum pulse width	No load	50	-	110	ns

1. See specific application note number: AN1994

Table 7. Threshold switching voltage variation with voltage on pin VL

Voltage on pin VL, V_L	V_{LOW} max.	V_{HIGH} min.	Unit
2.7	1.05	1.65	V
3.3	1.4	1.95	V
5.0	2.2	2.8	V

Table 8. Logic truth table

Pin TRISTATE	Inputs as per Figure 4		Transistors as per Figure 4				Output mode
	INxA	INxB	Q1	Q2	Q3	Q4	
0	x	x	Off	Off	Off	Off	Hi Z
1	0	0	Off	Off	On	On	Dump
1	0	1	Off	On	On	Off	Negative
1	1	0	On	Off	Off	On	Positive
1	1	1	On	On	Off	Off	Not used

Electrical characteristics

STA516B

3.1 Test circuits

Figure 3. Test circuit

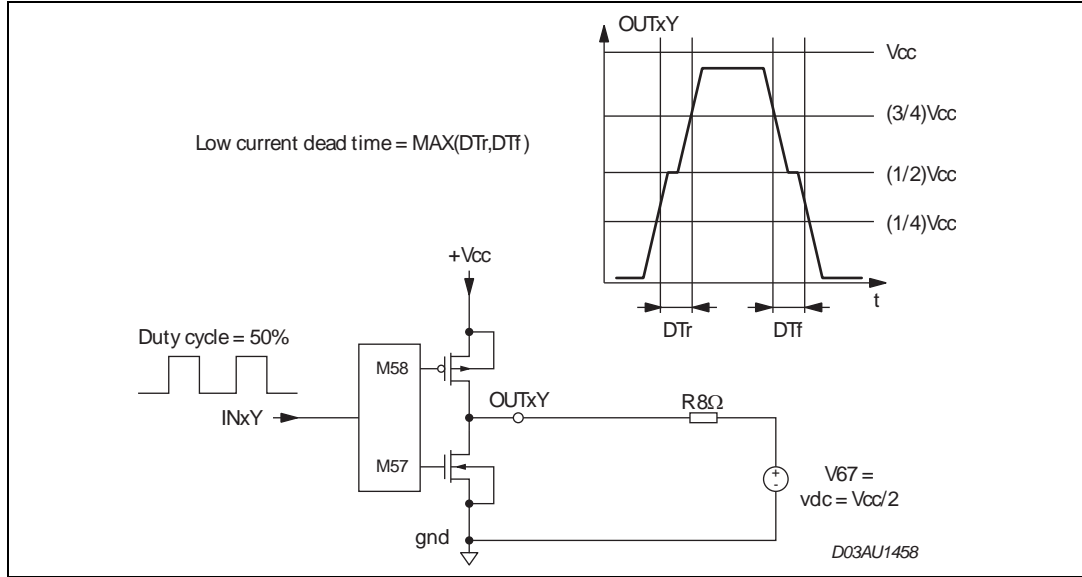
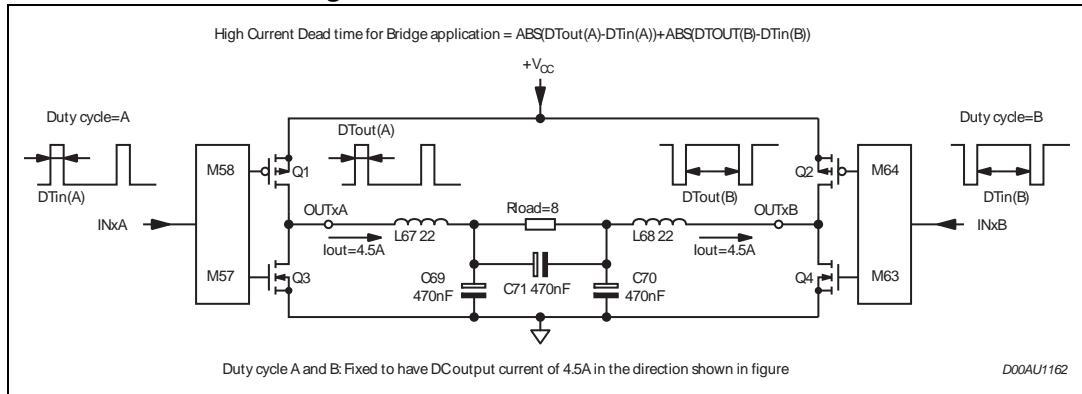

Figure 4. Current dead-time test circuit



4 Power supply and control sequencing

To guarantee correct operation and reliability, the recommended power-on sequence as given below should be followed:

- Apply V_{CC} and V_L , in any order, keeping PWRDN low in this phase
- Release PWRDN from low to high, keeping TRISTATE low (until V_{DD} and V_{SS} are stable)
- Release TRISTATE from low to high

Always maintain PWM inputs $IN_{xy} < V_L$.

Figure 5. Power-ON sequence

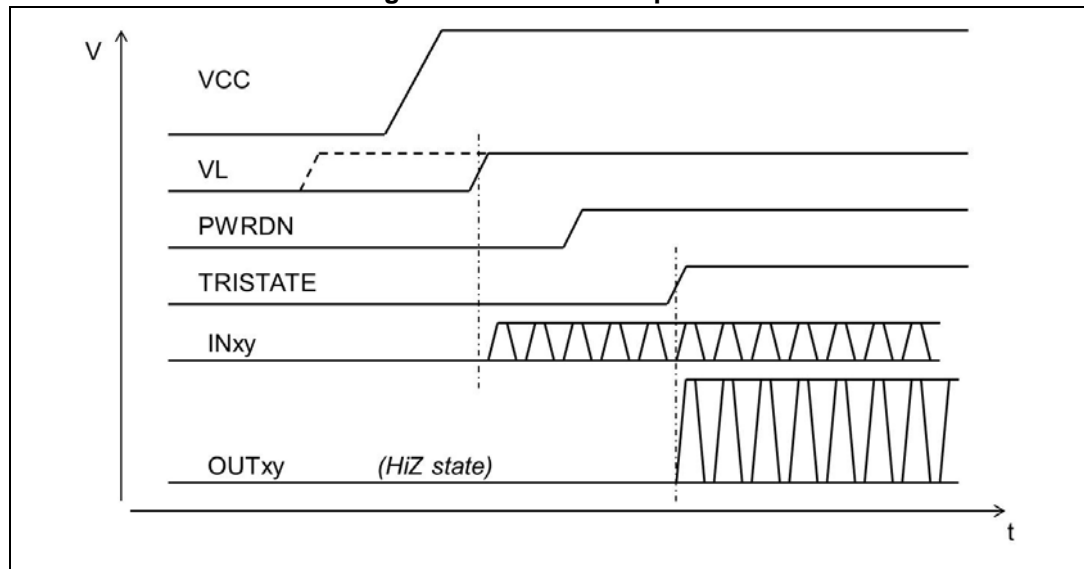

Power-OFF sequence:

- When TRISTATE or PWRDN go low, the outputs go into HiZ state
- Inputs IN_{xy} are removed before V_L is removed
- V_L can be removed before or after V_{CC}

Power supply and control sequencing

STA516B

Figure 6. Power-OFF sequence

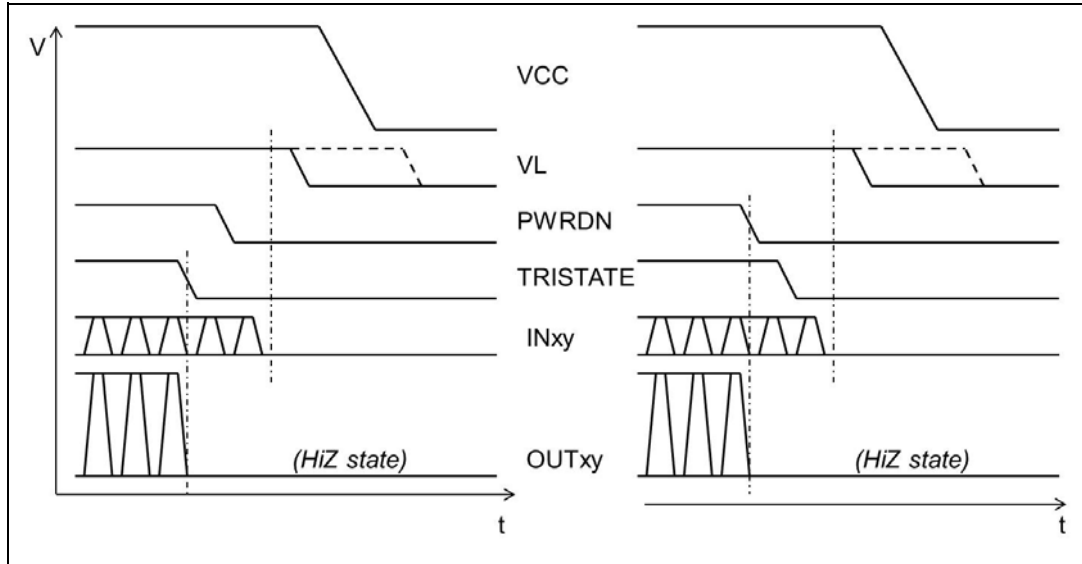

5 Technical information

The STA516B is a dual channel H-bridge that is able to deliver 200 W per channel (into $R_L = 6 \Omega$ with THD = 10% and $V_{CC} = 51 V$) of audio output power very efficiently. It operates in conjunction with a pulse-width modulator driver such as the STA321 or STA309A.

The STA516B converts ternary, phase-shift or binary-controlled PWM signals into audio power at the load. It includes a logic interface, integrated bridge drivers, high efficiency MOSFET outputs and thermal and short-circuit protection circuitry.

In differential mode (ternary, phase-shift or binary differential), two logic level signals per channel are used to control high-speed MOSFET switches to connect the speaker load to the input supply or to ground in a bridge configuration, according to the damped ternary modulation operation.

In binary mode, both full bridge and half bridge modes are supported. The STA516B includes overcurrent and thermal protection as well as an undervoltage lockout with automatic recovery. A thermal warning status is also provided.

Figure 7. Block diagram of full-bridge DDX[®] or binary mode

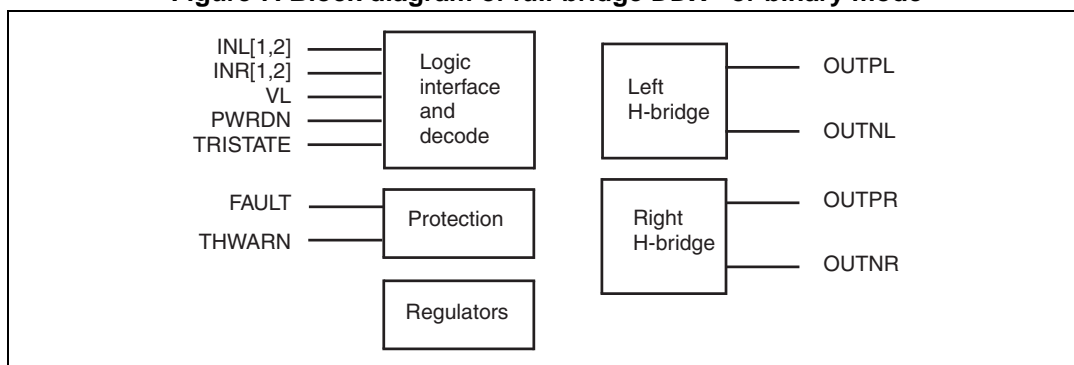
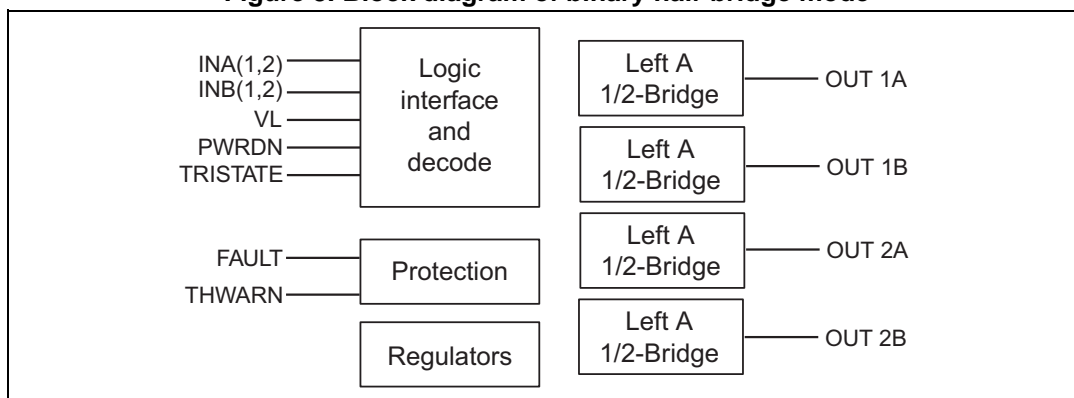

Figure 8. Block diagram of binary half-bridge mode



5.1 Logic interface and decode

The STA516B power outputs are controlled using one or two logic-level timing signals. In order to provide a proper logic interface, the V_L input must operate at the same voltage as the DDX control logic supply.

5.2 Protection circuitry

The STA516B includes protection circuitry for overcurrent and thermal overload conditions. A thermal warning pin (THWARN, pin 28, open drain MOSFET) is activated low when the IC temperature exceeds 130 °C, just in advance of thermal shutdown. When a fault condition is detected an internal fault signal immediately disables the output power MOSFETs, placing both H-bridges in a high-impedance state. At the same time the open-drain MOSFET of pin FAULT (pin 27) is switched on.

There are two possible modes subsequent to activating a fault.

- **Shutdown mode:** with pins FAULT (with pull-up resistor) and TRISTATE separate, an activated fault disables the device, signaling a low at pin FAULT output. The device may subsequently be reset to normal operation by toggling pin TRISTATE from high to low to high using an external logic signal.
- **Automatic recovery mode:** This is shown in the applications circuits below where pins FAULT and TRISTATE are connected together to a time-constant circuit (R59 and C58). An activated fault forces a reset on pin TRISTATE causing normal operation to resume following a delay determined by the time constant of the circuit. If the fault condition persists, the circuit operation repeats until the fault condition is cleared. An increase in the time constant of the circuit produces a longer recovery interval. Care must be taken in the overall system design not to exceed the protection threshold under normal operation.

5.3 Power outputs

The STA516B power and output pins are duplicated to provide a low-impedance path for the device bridged outputs. All duplicate power, ground and output pins must be connected for proper operation.

The PWRDN or TRISTATE pin should be used to set all power MOSFETs to the high-impedance state during power-up until the logic power supply, V_L , has settled.

5.4 Parallel output / high current operation

When using the DDX mode output, the STA516B outputs can be connected in parallel in order to increase the output current capability to a load. In this configuration the STA516B can provide up to 240 W into a 3 Ω load.

This mode of operation is enabled with the pin CONFIG (pin 24) connected to pin VDD. The inputs are joined so that IN1A = IN1B, IN2A = IN2B and similarly the outputs OUT1A = OUT1B, OUT2A = OUT2B as shown in [Figure 9 on page 13](#)

5.5 Output filtering

A passive 2nd order filter is used on the STA516B power outputs to reconstruct the analog audio signal. System performance can be significantly affected by the output filter design and choice of passive components. A filter design for 6 or 8 Ω loads is shown in the application circuit of [Figure 8](#), and for 3 or 4 Ω loads in [Figure 9](#) and [Figure 10](#).

6 Applications

Figure 9 below shows a single-BLT configuration capable of giving 400 W into a 3 Ω load at 10% THD with $V_{CC} = 52$ V. This result was obtained using the STA30X+STA50X demo board. Note that a PWM modulator as driver is required.

Figure 9. Typical single-BTL configuration for 400 W

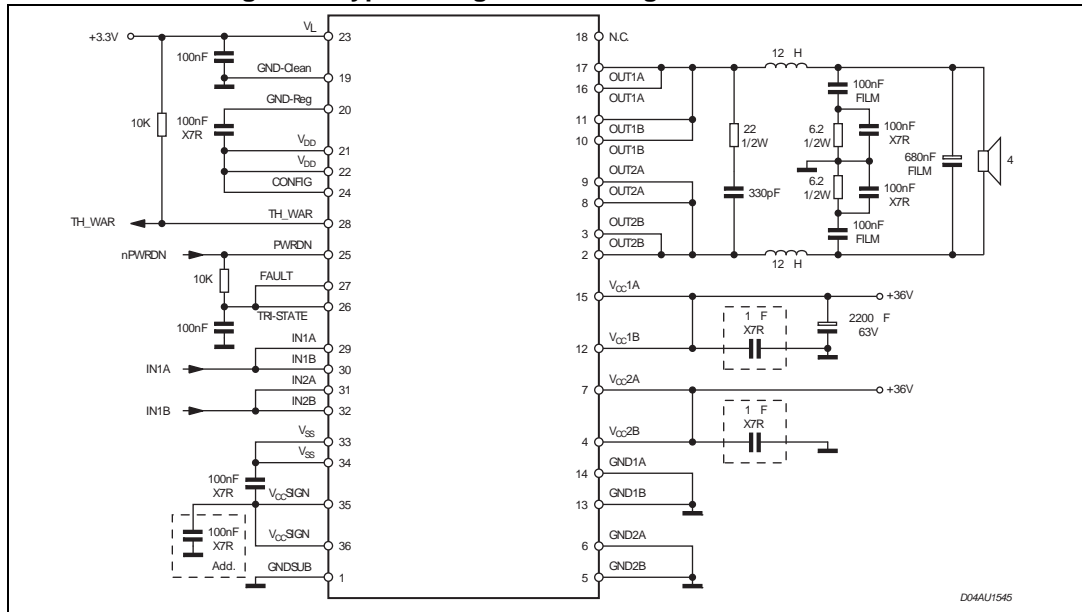
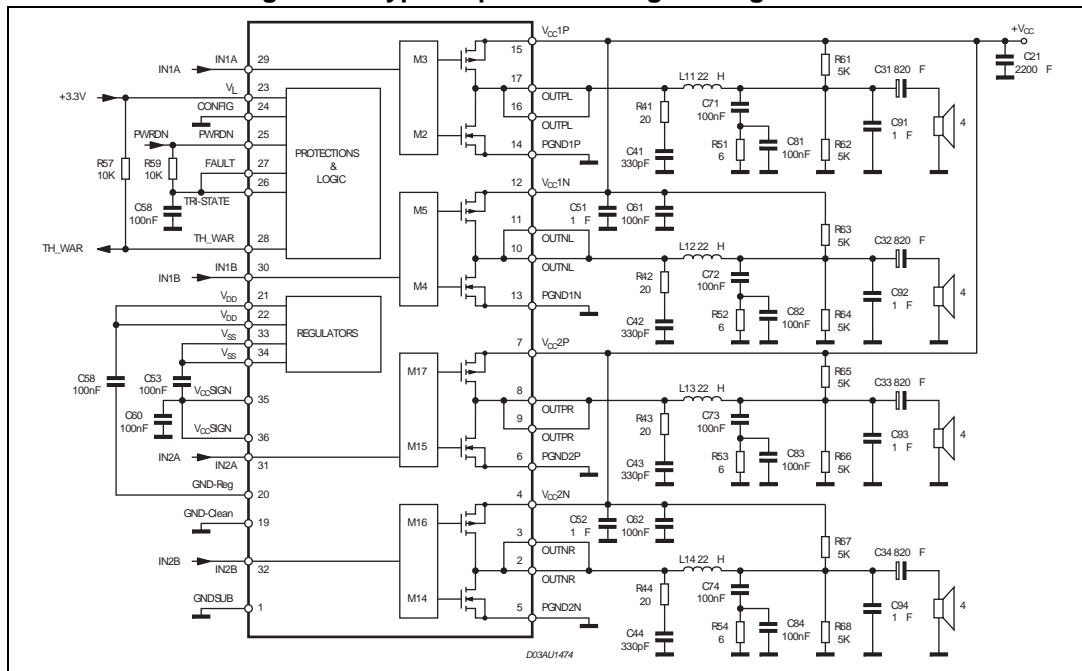

Figure 10. Typical quad half-bridge configuration



For more information, refer to the application note AN1994.

7 Package mechanical data

In order to meet environmental requirements, ST offers these devices in different grades of ECOPACK[®] packages, depending on their level of environmental compliance. ECOPACK[®] specifications, grade definitions and product status are available at: www.st.com. ECOPACK[®] is an ST trademark

Figure 11. PowerSO36 exposed pad up outline drawing

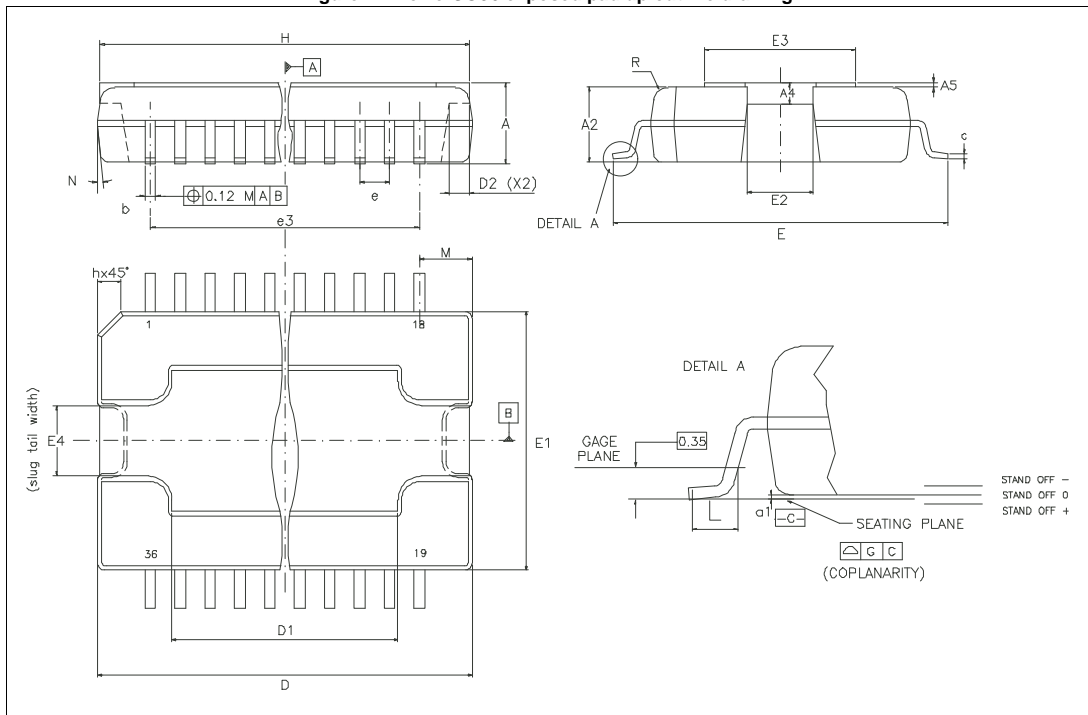

Package mechanical data

STA516B

Table 9. PowerSO36 exposed pad up dimensions

Symbol	mm.			inch.		
	Min.	Typ.	Max.	Min.	Typ.	Max.
A	3.25	-	3.43	0.128	-	0.135
A2	3.10	-	3.20	0.122	-	0.126
A4	0.80	-	1.00	0.031	-	0.039
A5	-	0.20	-	-	0.008	-
a1	0.03	-	-0.04	0.001	-	-0.002
b	0.22	-	0.38	0.009	-	0.015
c	0.23	-	0.32	0.009	-	0.013
D	15.80	-	16.00	0.622	-	0.630
D1	9.40	-	9.80	0.370	-	0.386
D2	-	1.00	-	-	0.039	-
E	13.90	-	14.50	0.547	-	0.571
E1	10.90	-	11.10	0.429	-	0.437
E2	-	-	2.90	-	-	0.114
E3	5.80	-	6.20	0.228	-	0.244
E4	2.90	-	3.20	0.114	-	0.126
e	-	0.65	-	-	0.026	-
e3	-	11.05	-	-	0.435	-
G	0	-	0.08	0	-	0.003
H	15.50	-	15.90	0.610	-	0.626
h	-	-	1.10	-	-	0.043
L	0.80	-	1.10	0.031	-	0.043
M	2.25	-	2.60	0.089	-	0.102
N	-	-	10 degrees	-	-	10 degrees
R	-	0.6	-	-	0.024	-
s	-	-	8 degrees	-	-	8 degrees

8 Revision history

Table 10. Document revision history

Date	Revision	Changes
01-Feb-2007	1	Initial release.
19-Mar-2007	2	Update to reflect product maturity.
11-Aug-2009	3	Updated section Description on cover page.
16-Nov-2010	4	Modified presentation Updated Chapter 3: Electrical specifications on page 5 Added Chapter 5: Applications information on page 10
15-Jan-2014	5	Modified Section 4: Power supply and control sequencing on page 9
11-Feb-2014	6	Updated order code Table 1 on page 1

Please Read Carefully:

Information in this document is provided solely in connection with ST products. STMicroelectronics NV and its subsidiaries ("ST") reserve the right to make changes, corrections, modifications or improvements, to this document, and the products and services described herein at any time, without notice.

All ST products are sold pursuant to ST's terms and conditions of sale.

Purchasers are solely responsible for the choice, selection and use of the ST products and services described herein, and ST assumes no liability whatsoever relating to the choice, selection or use of the ST products and services described herein.

No license, express or implied, by estoppel or otherwise, to any intellectual property rights is granted under this document. If any part of this document refers to any third party products or services it shall not be deemed a license grant by ST for the use of such third party products or services, or any intellectual property contained therein or considered as a warranty covering the use in any manner whatsoever of such third party products or services or any intellectual property contained therein.

UNLESS OTHERWISE SET FORTH IN ST'S TERMS AND CONDITIONS OF SALE ST DISCLAIMS ANY EXPRESS OR IMPLIED WARRANTY WITH RESPECT TO THE USE AND/OR SALE OF ST PRODUCTS INCLUDING WITHOUT LIMITATION IMPLIED WARRANTIES OF MERCHANTABILITY, FITNESS FOR A PARTICULAR PURPOSE (AND THEIR EQUIVALENTS UNDER THE LAWS OF ANY JURISDICTION), OR INFRINGEMENT OF ANY PATENT, COPYRIGHT OR OTHER INTELLECTUAL PROPERTY RIGHT.

ST PRODUCTS ARE NOT DESIGNED OR AUTHORIZED FOR USE IN: (A) SAFETY CRITICAL APPLICATIONS SUCH AS LIFE SUPPORTING, ACTIVE IMPLANTED DEVICES OR SYSTEMS WITH PRODUCT FUNCTIONAL SAFETY REQUIREMENTS; (B) AERONAUTIC APPLICATIONS; (C) AUTOMOTIVE APPLICATIONS OR ENVIRONMENTS, AND/OR (D) AEROSPACE APPLICATIONS OR ENVIRONMENTS. WHERE ST PRODUCTS ARE NOT DESIGNED FOR SUCH USE, THE PURCHASER SHALL USE PRODUCTS AT PURCHASER'S SOLE RISK, EVEN IF ST HAS BEEN INFORMED IN WRITING OF SUCH USAGE, UNLESS A PRODUCT IS EXPRESSLY DESIGNATED BY ST AS BEING INTENDED FOR "AUTOMOTIVE, AUTOMOTIVE SAFETY OR MEDICAL" INDUSTRY DOMAINS ACCORDING TO ST PRODUCT DESIGN SPECIFICATIONS. PRODUCTS FORMALLY ESCC, QML OR JAN QUALIFIED ARE DEEMED SUITABLE FOR USE IN AEROSPACE BY THE CORRESPONDING GOVERNMENTAL AGENCY.

Resale of ST products with provisions different from the statements and/or technical features set forth in this document shall immediately void any warranty granted by ST for the ST product or service described herein and shall not create or extend in any manner whatsoever, any liability of ST.

ST and the ST logo are trademarks or registered trademarks of ST in various countries.

Information in this document supersedes and replaces all information previously supplied.

The ST logo is a registered trademark of STMicroelectronics. All other names are the property of their respective owners.

© 2014 STMicroelectronics - All rights reserved

STMicroelectronics group of companies

Australia - Belgium - Brazil - Canada - China - Czech Republic - Finland - France - Germany - Hong Kong - India - Israel - Italy - Japan - Malaysia - Malta - Morocco - Philippines - Singapore - Spain - Sweden - Switzerland - United Kingdom - United States of America

www.st.com