

## Excellent Integrated System Limited

Stocking Distributor

Click to view price, real time Inventory, Delivery & Lifecycle Information:

[Molex Connector Corporation](#)  
[0847290005](#)

For any questions, you can email us directly:

[sales@integrated-circuit.com](mailto:sales@integrated-circuit.com)

MATERIAL NO.	LENGTH
847290003	6.00 IN +.47 -0 ( 152.0mm +12mm-0 )
847290004	31.88 IN +1.00-0 ( 810.0mm +25.4mm-0 )
847290005	51.57 IN +1.00-0 ( 1310.0mm +25.4mm-0 )
847290006	81.89 IN +1.57-0 ( 2080.0mm +40.0mm-0 )
847290007	131.10 IN +3.15-0 ( 3330mm +80.0mm-0 )
847290008	196.90 IN +3.94-0 ( 5000mm +100.0mm-0 )
847290011	3.00 IN +.47 -0 ( 76.2mm +12mm-0 )
847290020	12.00 IN +1.0 -0 ( 304.8mm +25.4mm-0 )

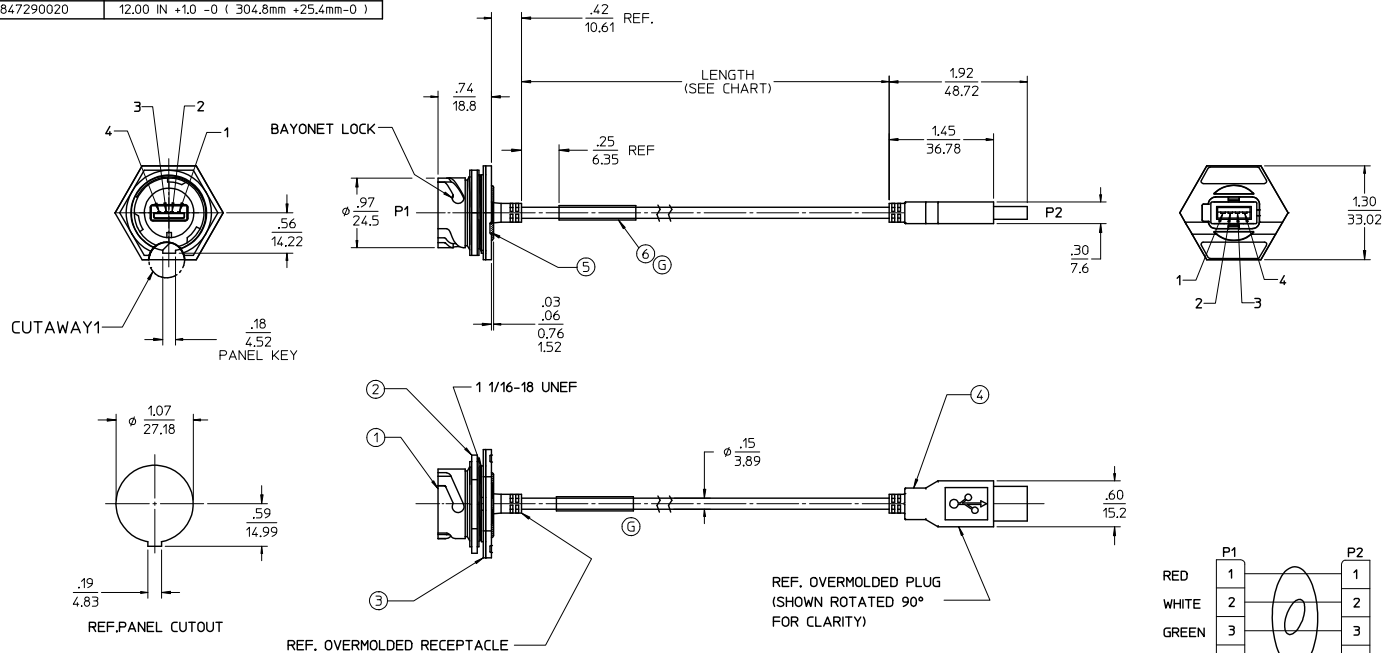

- NOTES:
1. MATERIAL: SEE TABLE
  2. FINISHES: SEE TABLE
  3. CABLE MATERIAL:  
OVERMOLD & JACKET: PVC  
SHELL: PHOSPHOR BRONZE, NI PLATED  
CONTACTS: PHOSPHOR BRONZE, GOLD PLATED  
WIRE: 28 AWG
  4. ASSEMBLY IS ROHS COMPLIANT

ITEM	QTY.	DESCRIPTION	MATERIAL	FINISH
6	1	WRAP LABEL	VINYL	YELLOW/BLACK
5	A/R	POTTING COMPOUND	EPOXY	BLACK
4	1	USB-A CABLE SUB-ASSEMBLY, SHIELDED	AS NOTED	AS NOTED
3	1	PANEL GASKET	NEOPRENE	BLACK
2	1	LOCKNUT	NYLON PA66, UL94HB	BLACK
1	1	RECEPTACLE HOUSING	PBT, UL94 V-0	BLACK

<b>ADDED LABEL</b> IEC NO: IFC2005-0785 DRAWING: DUSTAFSON 2014/10/28 CHK: KROBUPET 2014/11/30 APPR: BMOJMAN 2014/12/02 DESCRIPTION:	QUALITY SYMBOLS ▽=0 ▽=0	GENERAL TOLERANCES (UNLESS SPECIFIED) mm INCH 4 PLACES ± --- ± --- 3 PLACES ± --- ± --- 2 PLACES ± --- ± .01 1 PLACE ± 0.25 ± --- ANGULAR ± 1/2°	DIMENSION STYLE IN/MM DRAWN BY: R. STONE DATE: 2007/02/15 CHECKED BY: J. MACNEIL DATE: 2007/02/20 APPROVED BY: J. MACNEIL DATE: 2007/02/20	SCALE: 1:1 DESIGN UNITS: INCH THIRD ANGLE PROJECTION
	DRAFT WHERE APPLICABLE MUST REMAIN WITHIN DIMENSIONS		MATERIAL NO. SEE CHART SIZE C	TITLE: USB-A CORD ASSEMBLY PLUG & RECEPTACLE MOLEX INCORPORATED DOCUMENT NO. SD-84729-006 SHEET NO. 1 OF 1
	THIS DRAWING CONTAINS INFORMATION THAT IS PROPRIETARY TO MOLEX INCORPORATED AND SHOULD NOT BE USED WITHOUT WRITTEN PERMISSION			

MATERIAL NO.	LENGTH
847290010	6.00 IN +.47 -0 ( 152.0mm +12-0 )

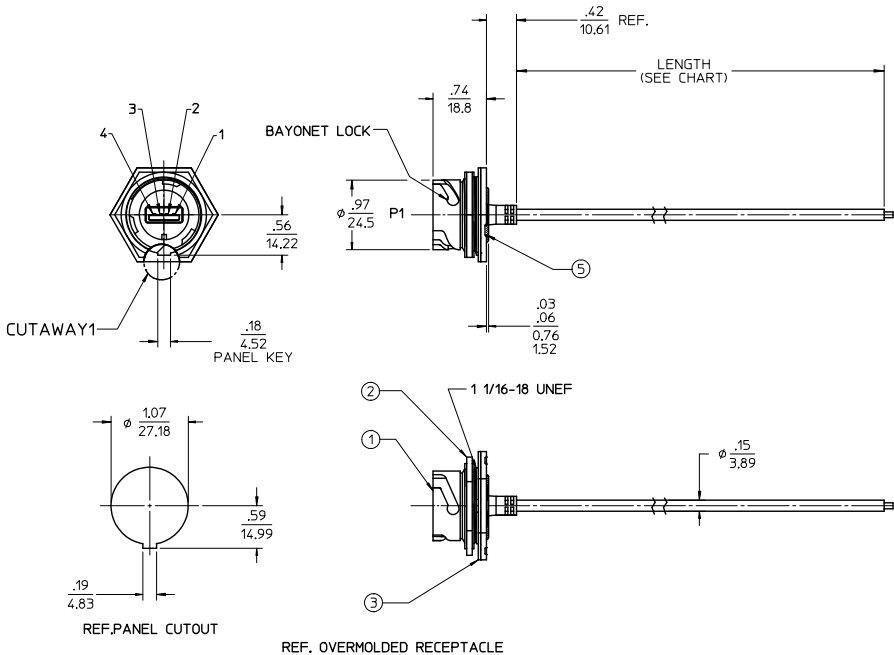

P1	
1	RED
2	WHITE
3	GREEN
4	BLACK
5	DRAIN

SHIELD

WIRING DIAGRAM

CUSTOMER PRODUCTION APPROVAL  
 APPROVED BY: \_\_\_\_\_  
 DATE: \_\_\_\_\_  
 MUST BE SIGNED AND RETURNED BEFORE  
 PRODUCTION WILL BEGIN.

SALES DRAWING

- NOTES:
1. MATERIAL: SEE TABLE
  2. FINISHES: SEE TABLE
  3. MATERIAL:  
CABLE: 28AWG, PVC, BLACK  
SHELL: PHOSPHOR BRONZE, NI PLATED  
CONTACTS: PHOSPHOR BRONZE, GOLD PLATED
  4. ASSEMBLY IS ROHS COMPLIANT
  5. PANEL THICKNESS: .10" MAX

ITEM	QTY.	DESCRIPTION	MATERIAL	FINISH
5		POTTING COMPOUND	EPOXY	BLACK
4	1	USB-A CABLE SUB-ASSEMBLY, SHIELDED	AS NOTED	AS NOTED
3	1	PANEL GASKET	NEOPRENE	BLACK
2	1	LOCKNUT	PBT, UL-94V-0	BLACK
1	1	RECEPTACLE HOUSING	PBT, UL-94V-0	BLACK

<b>UPDATED NOTES</b> EC NO: IFG2016-0788 DRAWING STAFF: SUN 2015/11/23 CHK: BARDEN 2015/12/15 APPR: BOLDMAN 2015/12/16	<b>QUALITY SYMBOLS</b> ▽=0 ▽=0	<b>GENERAL TOLERANCES (UNLESS SPECIFIED)</b>		<b>DIMENSION STYLE</b> IN/MM		SCALE 1:1	DESIGN UNITS INCH	THIRD ANGLE PROJECTION		
		4 PLACES ± --- ± ---	3 PLACES ± --- ± ---	2 PLACES ± --- ± .01	1 PLACE ± 0.25 ± ---	ANGULAR ± 1/2°	DRAWN BY R. STONE	DATE 2007/02/15	TITLE USB-A CORD ASSEMBLY RECEPTACLE	
		DRAFT WHERE APPLICABLE MUST REMAIN WITHIN DIMENSIONS		SEE CHART		APPROVED BY J. MACNEIL	DATE 2007/02/20	MOLEX INCORPORATED		
						MATERIAL NO. SD-84729-010	DOCUMENT NO.	SHEET NO. 1 OF 1		