

Excellent Integrated System Limited

Stocking Distributor

Click to view price, real time Inventory, Delivery & Lifecycle Information:

[Molex Connector Corporation](#)
[0638665000](#)

For any questions, you can email us directly:

sales@integrated-circuit.com

Fine Adjust Applicator for MX64 GET Crimp Terminals

**FineAdjust
Applicator**



**Application Tooling
Specification Sheet**

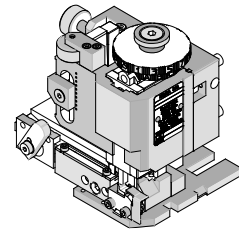

Order No. 63866-5000

FEATURES

- Quick punch removal with the push of a button for fast and easy tooling change
- Applicator designed to industry standard mounting and shut height 135.80mm (5.346")
- Quick set-up time; plus the crimp height, track and feed adjustments can be set without removing the applicator from the press
- Fine adjustment allows users to achieve target with little effort by adjusting in increments of .015mm (.0006") for conductor crimp height and .063mm (.0025") for insulation height
- Independent adjustment rings allow users to quickly adjust the conductor or insulation crimp height without affecting each other
- Directly adapts to most automatic wire processing machines

SCOPE

Products: MX64 GET Receptacle Terminal, 18-20 AWG and 0.50-0.75mm².

Terminal Order No.	Wire Size	Actual mm ²	Wire Specification		Insulation Diameter		Strip Length	
			Low Temp.	High Temp.	mm	In.	mm	In.
34230-0003	20 AWG	0.562	WSB-M1L134-A1	WSS-M1L135-A1	1.70-1.85	.067-.073	4.00-4.80	.157-.189
			ESB-M1L120-A	ESB-M1L123-A/A2				
	0.50mm ²	0.490	WSK-M1L124-A	S97GG-14401-AA	1.40-1.60	.055-.063	4.00-4.80	.157-.189
			WSB-M1L134-A1	WSS-M1L135-A1				
18AWG	0.806	0.806	WSB-M1L134-A1	WSS-M1L135-A1	1.91-2.06	.075-.081	4.00-4.80	.157-.189
			ESB-M1L120-A	ESB-M1L123-A/A2				
	0.75mm ²	0.737	WSK-M1L124-A	S97GG-14401-AA	1.70-1.90	.067-.075	4.00-4.80	.157-.189

DEFINITION OF TERMS

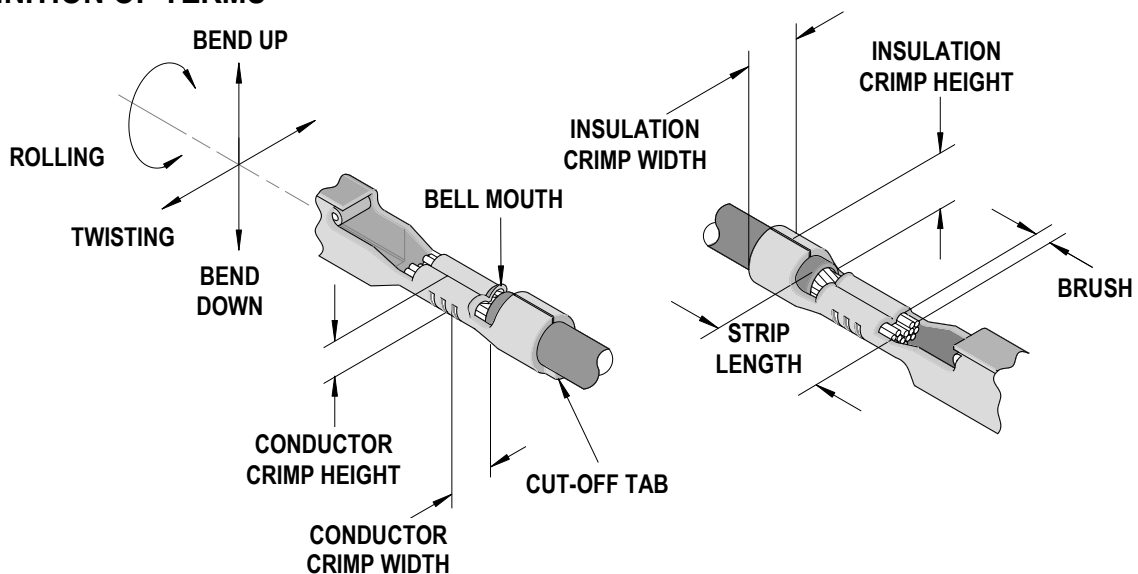

Fine Adjust Applicator for MX64 GET Crimp Terminals

CRIMP SPECIFICATION

Terminal Series No.	Bell mouth (Front Only)		Cut-off Tab Max.		Conductor Brush	
	mm	In.	mm	In.	mm	In.
34230-0003	0.20-0.50	.008-.020	0.50	.020	0.10-1.00	.004-.039

Terminal Order No.	Wire Size	Actual mm ²	Bend up	Bend down	Twist	Roll	Punch Width (Ref)				Seam Seam shall not be open and no wire allowed out of the crimping area
			Degree		Degree		Conductor		Insulation		
							mm	In	mm	In	
34230-0003	18 AWG	0.806	2.5	2.5	1.5	N/A	1.80	.070	1.85	.073	
	20 AWG	0.562	3	3	2.5	N/A	1.80	.070	1.85	.073	
	0.75mm ²	0.737	2.5	2.5	1.5	N/A	1.80	.070	1.85	.073	
	0.50mm ²	0.490	3	3	2.5	N/A	1.80	.070	1.85	.073	

After crimping, the conductor profile should measure the following.

Terminal Order No.	Wire Size	Actual mm ²	Wire Specification		Conductor				Pull Force Minimum	
			Low Temp	High Temp	Crimp Height		Crimp Width		N	Lb.
					mm	In.	mm	In.		
34230-0003	18 AWG	0.806	WSB-M1L134-A1	WSS-M1L135-A1	1.16-1.24	.046-.049	1.83-1.91	.072-.075	115.0	25.88
			ESB-M1L120-A	ESB-M1L123-A/A2	1.16-1.24	.046-.049	1.83-1.91	.072-.075	115.0	25.88
	20 AWG	0.562	WSB-M1L134-A1	WSS-M1L135-A1	1.04-1.12	.041-.044	1.82-1.90	.072-.075	75.0	16.88
			ESB-M1L120-A	ESB-M1L123-A/A2	1.04-1.12	.041-.044	1.82-1.90	.072-.075	75.0	16.88
	0.75mm ²	0.737	WSK-M1L124-A	S97GG-14401-AA	1.12-1.20	.044-.047	1.83-1.91	.072-.075	115.0	25.88
	0.50mm ²	0.490	WSK-M1L124-A	S97GG-14401-AA	1.02-1.10	.040-.043	1.82-1.90	.072-.075	75.0	16.88

Terminal Order No.	Wire Size	Actual mm ²	Wire Specification		Insulation			
			Low Temp	High Temp	Crimp Height		Crimp Width	
					mm	In.	mm	In.
34230-0003	18 AWG	0.806	WSB-M1L134-A1	WSS-M1L135-A1	1.90-2.10	.075-.083	1.85-2.05	.073-.081
			ESB-M1L120-A	ESB-M1L123-A/A2	1.90-2.10	.075-.083	1.85-2.05	.073-.081
	20 AWG	0.562	WSB-M1L134-A1	WSS-M1L135-A1	1.80-2.00	.071-.079	1.85-2.05	.073-.081
			ESB-M1L120-A	ESB-M1L123-A/A2	1.90-2.10	.075-.083	1.85-2.05	.073-.081
	0.75mm ²	0.737	WSK-M1L124-A	S97GG-14401-AA	1.90-2.10	.075-.083	1.85-2.05	.073-.081
	0.50mm ²	0.490	WSK-M1L124-A	S97GG-14401-AA	1.80-2.00	.071-.079	1.85-2.05	.073-.081

■ Tool Qualification Notes:

1. Pull Force should be measured with no influence from the insulation crimp.
2. The above specifications are guidelines to an optimum crimp.

Fine Adjust Applicator for MX64 GET Crimp Terminals

PARTS LIST

FineAdjust Applicator 63866-5000				
Item	Order No	Engineering No.	Description	Quantity
Perishable Tooling				
	63866-5070	63866-5070	Tool Kit (All "Y" Items)	REF
1	63457-0020	63457-0020	Conductor Punch	1 Y
2	63455-0020	63455-0020	Conductor Anvil	1 Y
3	63454-0032	63454-0032	Insulation Punch	1 Y
4	63456-0027	63456-0027	Insulation Anvil	1 Y
5	63461-0001	63461-0001	Cut-Off Plunger	1 Y
6	63443-0036	63443-0036	Front Plunger Retainer	1 Y
Other Components				
7	11-17-0022	1739-21	Hold Down Spring	1
8	11-18-4094	60709A111	Feed Guide	1
9	63443-0009	63443-0009	Front Scrap Chute	1
10	63443-0021	63443-0021	Lower Tooling Key	1
11	63443-0061	63443-0061	Wire Stop	1
12	63443-0093	63443-0093	Shank	1
13	63443-2510	63443-2510	Anvil Mount	1
14	63443-3160	63443-3160	Front Plunger Striker	1
15	63443-6009	63443-6009	Rear Cover	1
16	63443-7126	63443-7126	Terminal Hold-Down	1
17	63700-0539	63700-0539	Cut-Off Plunger Spring	1
Frame				
18	63800-4901	63800-4901	Top	1
19	63801-3281	63801-3281	Base	1
20	63801-4650	63801-4650	Track	1
Hardware				
21	N/A	N/A	M3 by 6 Long SHCS	2**
22	N/A	N/A	M3 by 8 Long SHCS	1**
23	N/A	N/A	M4 by 6 Long SHCS	1**
24	N/A	N/A	M4 by 12 Long BHCS	2**
25	N/A	N/A	M4 by 50 Long SHCS	2**
26	N/A	N/A	M5 by 12 Long SHCS	1**
27	N/A	N/A	#10-32 by 3/8" Long Flat Point SSS	1**
28	N/A	N/A	#10-32 Hex Jam Nut	1**
29	N/A	N/A	3MM by 6 Long Roll Pin	1**
** Available from an industrial supply company such as MSC (1-800-645-7270).				

Fine Adjust Applicator for MX64 GET Crimp Terminals

Assembly Drawing

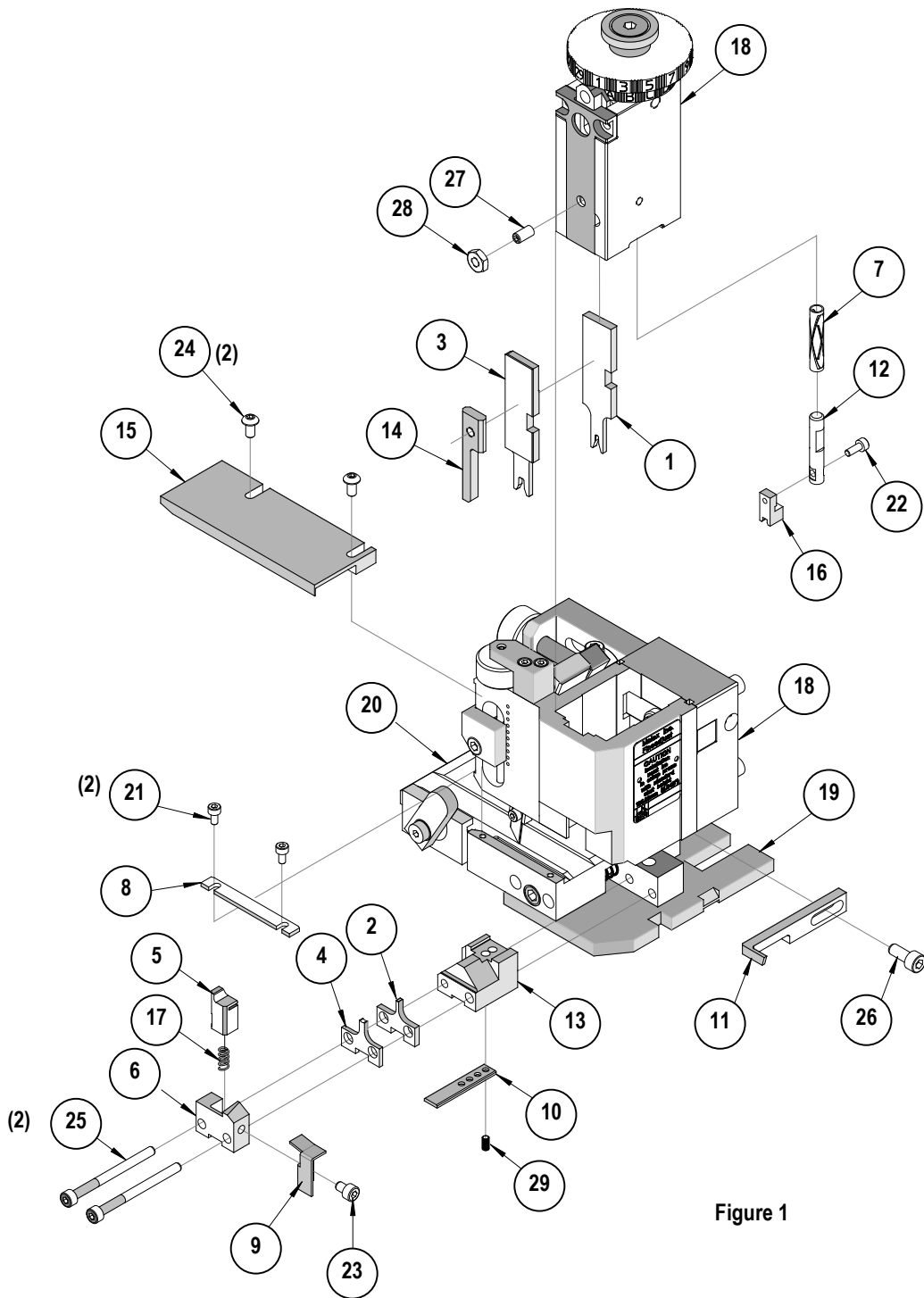

Figure 1

Fine Adjust Applicator for MX64 GET Crimp Terminals

NOTES

1. Molex recommends an extra perishable tooling kit be maintained at your facility.
2. Verify tooling alignment by manually cycling the press and Applicator before crimping under power. Check that all screws are tight.
3. Slugs, Terminals, Dirt and Oil should be kept clear of work area.
4. Wear safety glasses at all times.
5. For recommended maintenance refer to the FineAdjust Manual.

CAUTION: This applicator should only be used in a press with a shut height of 135.80 mm (5.346"). Tooling damage could result at a lower setting.

CAUTION: To prevent injury never operate this Applicator without the guards supplied with the press or wire-processing machine in place. Reference the press or wire processing manufacturer's instruction manual.

CAUTION: Molex crimp specifications are valid only when used with Molex terminals, applicators and tooling.

Visit our Web site at <http://www.molex.com>