

Excellent Integrated System Limited

Stocking Distributor

Click to view price, real time Inventory, Delivery & Lifecycle Information:

[Molex Connector Corporation](#)
[0638685070](#)

For any questions, you can email us directly:

sales@integrated-circuit.com

63868-5000 Fine Adjust Applicator



**FineAdjust Applicator
Specification Sheet
Part No. 63868-5000**

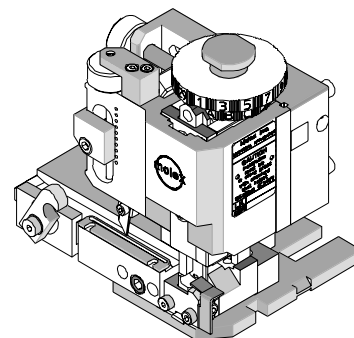

FEATURES

- Quick punch removal with the push of a button for fast and easy tooling change
- Applicator designed to industry standard mounting and shut height 135.80mm (5.346")
- Quick set-up time; plus the crimp height, track and feed adjustments can be set without removing the applicator from the press
- Fine adjustment allows users to achieve target with little effort by adjusting in increments of .015mm (.0006") for conductor crimp height and .063mm (.0025") for insulation height
- Independent adjustment rings allow users to quickly adjust the conductor or insulation crimp height without affecting each other
- Directly adapts to most automatic wire processing machines

SCOPE

Products: 2.50mm (.098") Pitch Board-In Terminal 22-28 AWG

Terminal Series No.	Wire Size		Insulation Diameter		Strip Length	
	AWG	mm ²	mm	In.	mm	In.
35047	22-28	0.08-0.32	1.15-1.90	.045-.075	3.00-3.50	.118-.138

Note: Terminal will accommodate UL1007 and UL1569 Wires

Terminals must be wound for a left to right feed applicator. Terminals 35047-9802 are wound in the opposite direction so they must be rewound to run through this applicator.

DEFINITION OF TERMS

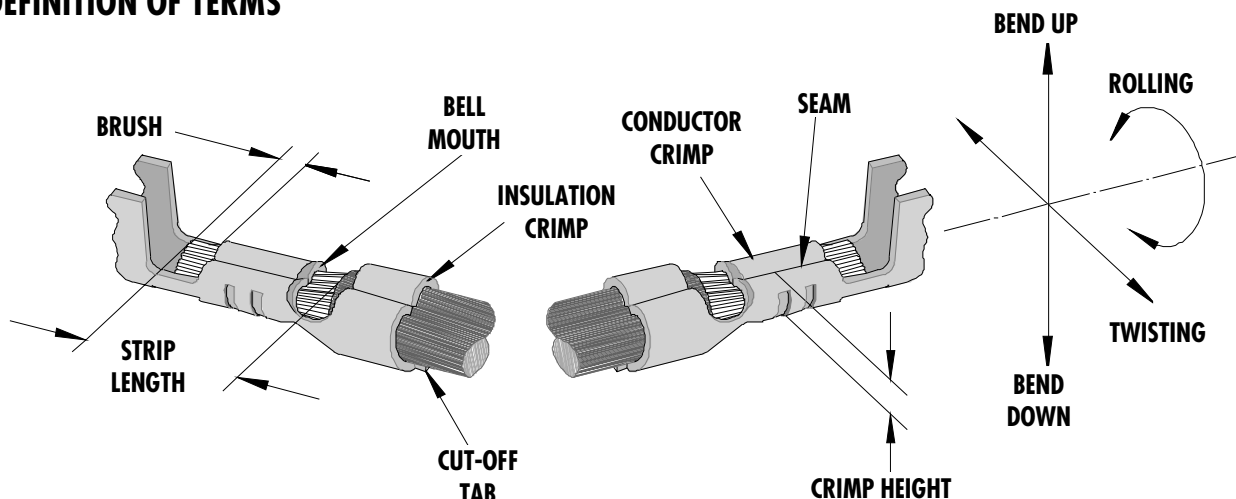

The above terminal drawing is a generic terminal representation. It is not an image of any terminal listed in the scope.

63868-5000 Fine Adjust Applicator

CRIMP SPECIFICATION

Terminal Series No.	Bell mouth		Cut-off Tab Max.		Conductor Brush	
	mm	In.	mm	In.	mm	In.
35047	0.20-0.50	.008-.020	0.30	.012	0.00-1.40	.000-.055

Terminal Series No.	Bend up	Bend down	Twist	Roll	Punch Width (Ref)				Seam Seam shall not be open and no wire allowed out of the crimping area
					Conductor		Insulation		
	Degree	Degree	mm	In	mm	In			
35047	3	3	3	3	1.40	.055	1.90	.075	

After crimping, the crimp profiles should measure the following:

Terminal Series No.	Wire Size		Conductor			
			Crimp Height		Crimp Width (Ref)	
	AWG	mm ²	mm	In.	mm	In.
35047	22	0.32	0.82-0.87	.032-.034	1.40 +/- 0.10	.055 +/- .004
35047	24	0.20	0.75-0.80	.029-.031	1.40 +/- 0.10	.055 +/- .004
35047	26	0.13	0.70-0.75	.027-.029	1.40 +/- 0.10	.055 +/- .004
35047	28	0.08	0.66-0.71	.026-.028	1.40 +/- 0.10	.055 +/- .004

Terminal Series No.	Wire Size		Insulation				Pull Force Min.	
			Crimp Height (Ref)		Crimp Width (Ref)			
	AWG	mm ²	mm	In.	mm	In.	N	Lb.
35047	22	0.32	1.60	.063	1.90 +/- 0.10	.075 +/- .004	39.1	8.8
35047	24	0.20	1.50	.059	1.90 +/- 0.10	.075 +/- .004	29.3	6.6
35047	26	0.13	1.45	.057	1.90 +/- 0.10	.075 +/- .004	19.6	4.4
35047	28	0.08	1.40	.055	1.90 +/- 0.10	.075 +/- .004	9.8	2.2

* Tool Qualification Notes:

1. This Applicator was qualified to the above specifications with UL1007 wire.
2. Pull Force should be measured with no influence from the insulation crimp.
3. The above specifications are guidelines to an optimum crimp.

63868-5000 Fine Adjust Applicator

PARTS LIST

FineAdjust Applicator 63868-5000				
Item	Order No	Engineering No.	Description	Quantity
Perishable Tooling				
	63868-5070	63868-5070	Tool Kit (All "Y" Items)	REF
1	63444-1407	63444-1407	Conductor Punch	1 Y
2	63445-1430	63445-1430	Conductor Anvil	1 Y
3	63446-1906	63446-1906	Insulation Punch	1 Y
4	63445-1906	63445-1906	Insulation Anvil	1 Y
5	63443-0002	63443-0002	Cut-Off Plunger Front	1 Y
6	63443-0012	63443-0012	Plunger Retainer Front	1 Y
Other Components				
7	11-24-1067	4996-4	Cut-off Plunger Spring	1
8	11-40-4039	8302-5	Plunger Striker Front	1
9	63443-0021	63443-0021	Lower Tooling Key	1
10	63443-6003	63443-6003	Rear Cover	1
11	11-18-4083	60707-8	Front Cover	1
12	63443-2430	63443-2430	Anvil Mount	1
13	63443-4005	63443-4005	Wire Stop	1
14	63443-0009	63443-0009	Scrap Chute Front	1
Frame				
15	63800-4900	63800-4900	Fine Adjust Applicator Frame	1
Hardware				
16	N/A	N/A	M3 by 6Lg. SHCS	2**
17	N/A	N/A	M4 by 6Lg. SHCS	1**
18	N/A	N/A	M4 by 12Lg. BHCS	2**
19	N/A	N/A	M4 by 16Lg SHCS	1**
20	N/A	N/A	M4 by 20Lg. SHCS	1**
21	N/A	N/A	M4 by 50Lg. SHCS	1**
22	N/A	N/A	3MM by 6Lg. Roll Pin	1**
23	N/A	N/A	#10-32 by 1/4"Lg. BHCS	1**

** Available from an industrial supply company such as MSC (1-800-645-7270).

63868-5000 Fine Adjust Applicator

Assembly Drawing

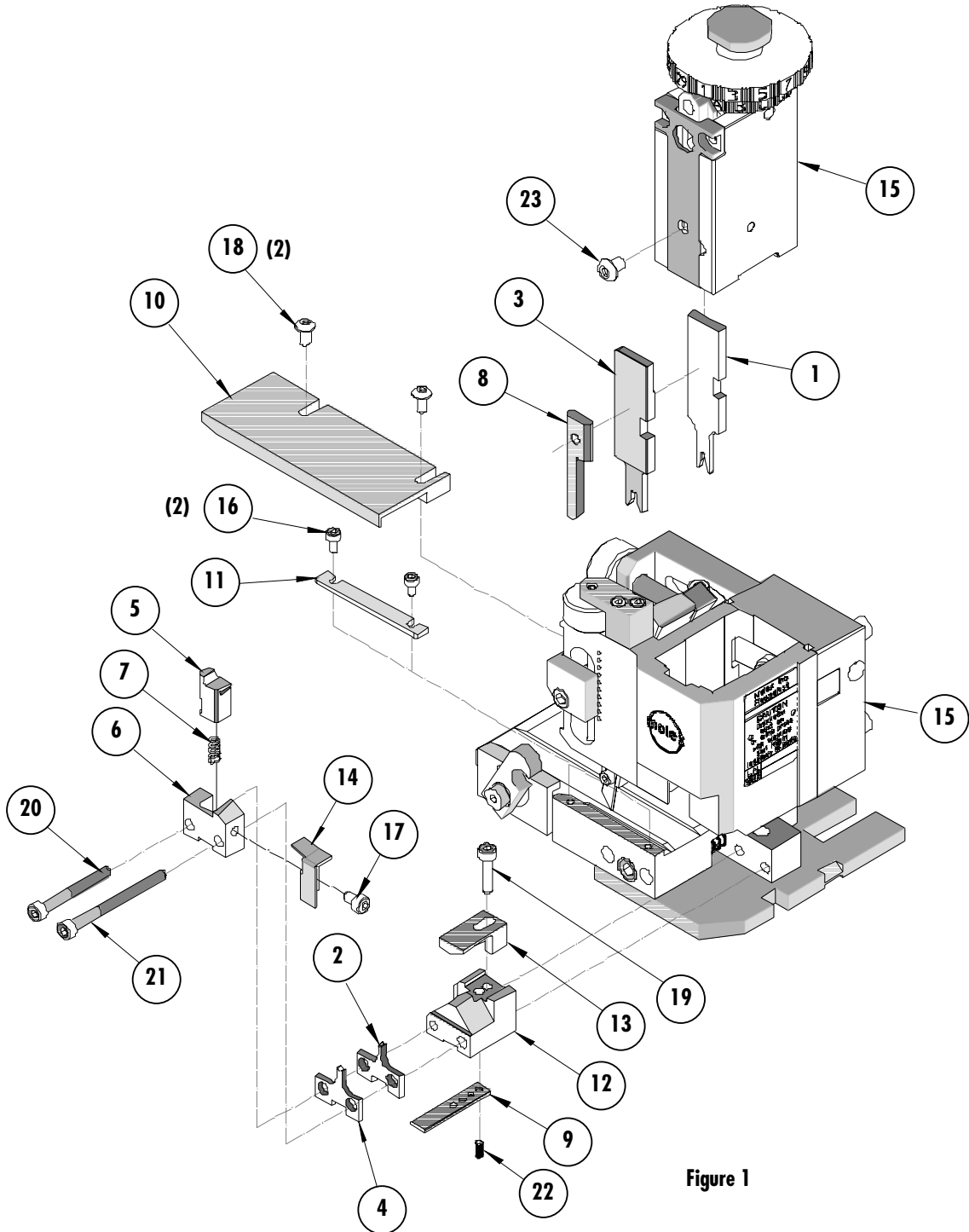

Figure 1

63868-5000 Fine Adjust Applicator

NOTES

1. Molex recommends an extra perishable tooling kit be maintained at your facility.
2. Verify tooling alignment by manually cycling the press and Applicator before crimping under power. Check that all screws are tight.
3. Slugs, Terminals, Dirt and Oil should be kept clear of work area.
4. Wear safety glasses at all times.
5. For recommended maintenance refer to the FineAdjust Manual.

CAUTION: This applicator should only be used in a press with a shut height of 135.80 mm (5.346"). Tooling damage could result at a lower setting.

CAUTION: To prevent injury never operate this Applicator without the guards supplied with the press or wire-processing machine in place. Reference the press or wire processing manufacturer's instruction manual.

CAUTION: Molex crimp specifications are valid only when used with Molex terminals, applicators and tooling.

Molex Application Tooling Group

2200 Wellington Court

Lisle, IL 60532

Tel: (630) 969-4550

Fax: (630) 505-0049

Visit our Web site at <http://www.molex.com>