

## Excellent Integrated System Limited

Stocking Distributor

Click to view price, real time Inventory, Delivery & Lifecycle Information:

[Molex Connector Corporation](#)  
[0638810100](#)

For any questions, you can email us directly:  
[sales@integrated-circuit.com](mailto:sales@integrated-circuit.com)

Mechanical Feed Metal Strip Applicator



**Mini-Mac Applicator  
 Application Tooling Specification  
 Mechanical Feed-Metal Strip  
 Order No. 63881-0100**

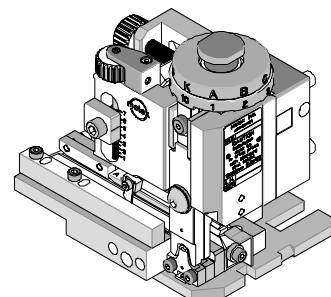

**FEATURES**

- | Directly adapts to most crimp presses and automatic wire processors
- | Applicator designed to industry standard mounting and shut height of 135.80mm (5.346")
- | Conductor and insulation rings allow quick adjustment for conductor and insulation crimp height change
- | Quick set-up time; plus the crimp height, track and feed adjustments can be set without removing the applicator from the crimp press

**SCOPE**

Products: Avikrimp® Metal strip fed Female Quick Disconnects Terminals 24-26 AWG

**Testing**

**Mechanical**

The tensile test, or pull test, is a means of evaluating the mechanical properties of the crimped connections. The following chart shows the UL and government specifications (MIL-T-7928) for various wire sizes. The tensile strength is shown in pounds and indicates the minimum acceptable force to break or separate the terminal from the conductor.

Color Code	Wire Size (AWG)	*UL - 486 A	*UL - 486 C	*UL - 310	*Military Class 2
Yellow	26	3	N/A	N/A	7
Yellow	24	5	N/A	N/A	10
Red	22	8	8	8	15
Red	20	13	10	13	19
Red	18	20	10	20	38
Blue	16	30	15	30	50
Blue	14	50	25	50	70
Yellow	12	70	35	70	110
Yellow	10	80	40	80	150
Red	8	90	45	N/A	225
Blue	6	100	50	N/A	300

\*UL - 486 A - Terminals (Copper conductors only)

\*UL - 486 C - Butt Splices, Parallel Splices, Closed End Connectors, and Wire Nuts

\*UL - 310 - Quick Disconnects, Flag and Couplers

\*Military Class 2- Military Approved Terminals only as listed

Mechanical Feed Metal Strip Applicator

**Product List**

The following is a partial list of the product order numbers and their specifications that this tool is designed to run. Updates to this list are available on [www.molex.com](http://www.molex.com).

Terminal No.	Terminal Eng. No.	Wire Size		Insulation Diameter Max.		Strip Length	
		AWG	mm <sup>2</sup>	mm	In.	mm	In.
19019-0047	MZ-8130	24-26	0.20-0.12	1.80	.071	4.76	.187
19019-0081	MZ-8133	24-26	0.20-0.12	1.80	.071	4.76	.187
19019-0082	MZ-8136	24-26	0.20-0.12	1.80	.071	4.76	.187
19019-0083	MZ-8136-032	24-26	0.20-0.12	1.80	.071	4.76	.187

**DEFINITION OF TERMS**

The following illustrations are a generic terminal representation and not an exact image of any terminal listed in the scope.

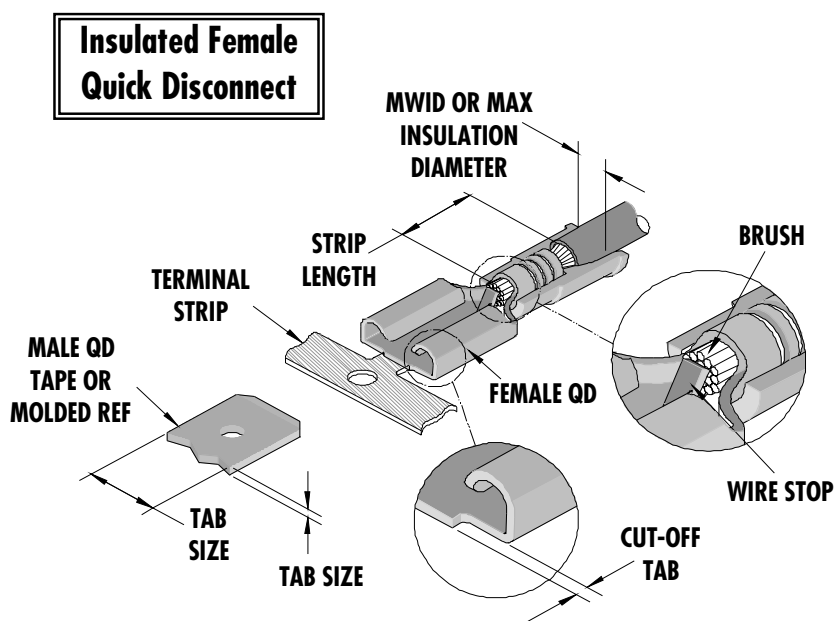

Figure 1

Mechanical Feed Metal Strip Applicator

### Tool Calibration

To recalibrate this applicator, make sure the power is completely shut off on the press.

1. The Mini-Mac applicator must be properly installed in the press.
2. Crimping dies must be properly installed in the Mini-Mac applicator.
3. The recommended method of measuring the crimp height of the conductor dies is the soft metal slug method, (See Figure 2).
4. The slug must have a diameter 0.51 mm (.020") larger than the "X" No Go dimension before crimping.
5. Place the soft metal slug (solder) into the nest of the bottom die and crimp (by hand cycling the press) similar to a terminal. The crimp height can be measured with a blade type micrometer or dial caliper, (Dimension "X").
6. Adjustment of the crimp height can be accomplished by indexing the conductor cam. The letter "A" gives the loosest position and "K" gives the tightest position. A total adjustment of 0.50mm (.020") can be achieved by adjusting the conductor cam.

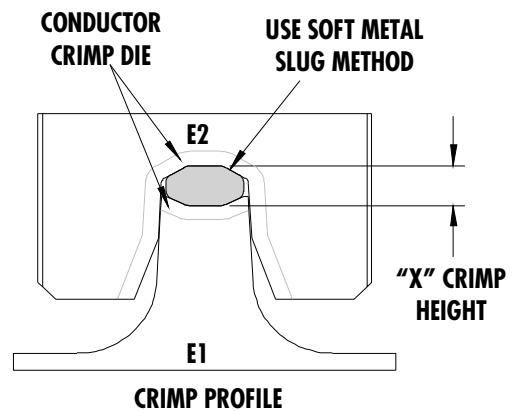

Use soft metal slug (solder) method to measure the "X" dimension. Verify tooling crimp height calibration by referring to the Go/No Go dimensions shown in the chart below.

Figure 2

Note: If the crimp height is too tight on the setting "A", check the shut height of the press. See the Industrial Mini-Mac Applicator Manual Section 2.1 for adjustments.

### CRIMP SPECIFICATIONS

Wire Size		"X" Dimension Conductor Crimp						Pull Force Min.	
AWG	mm <sup>2</sup>	Mean		Go		No Go		Lbs	N
		In	mm	In	mm	In	mm		
24	0.20	.070	1.78	.067	1.70	.075	1.91	5.0	22.0
26	0.12	.070	1.78	.067	1.70	.075	1.91	3.0	13.0

Terminal Series No.	Cut-off Tab Max.	
	mm	In.
19019-00**	0.25	.010

Pull Force should be measured with no influence from the insulation crimp. The above specifications are guidelines to an optimum crimp.

Mechanical Feed Metal Strip Applicator

**PARTS LIST**

Mini-Mac Applicator 63881-0100				
Item	Order No	Engineering No.	Description	Quantity
<b>Perishable Tooling</b>				
	<b>63881-0170</b>	<b>63881-0170</b>	<b>Tool Kit (All "Y" Items)</b>	<b>REF</b>
1	63465-0028	63465-0028	Conductor Punch	1 Y
2	63464-0026	63464-0026	Conductor Anvil	1 Y
3	63463-0026	63463-0026	Insulation Punch	1 Y
4	63462-0028	63462-0028	Insulation Anvil	1 Y
12	63466-0201	63466-0201	Cut-off Plunger Rear	1 Y
14	63466-0301	63466-0301	Rear Plunger Retainer	1 Y
16	63466-0002	63466-0002	Cut-Off Blade	1 Y
<b>Other Components (Ref. 10150)</b>				
22	63466-0403	63466-0403	Cut-off Plunger Striker (Rear)	1
24	63466-0101	63466-0101	Scrap Chute	1
25	63700-0539	63700-0539	Cut-Off Plunger Spring	1
33	63443-0021	63443-0021	Lower Tooling Key	1
35	63466-1058	63466-1058	Spacer	1
36	63466-1071	63466-1071	Spacer	1
42	63466-0921	63466-0921	Terminal Stripping Blade	1
51	63600-1290	63600-1290	Washer	1
52	63890-0866	63890-0866	Collar-6.40mm Lg.	1
53	63890-0867	63890-0867	Collar-7.70mm Lg.	1
72	63801-4510	63801-4510	Terminal Guide Front	1
96	63600-0110	63600-0110	M4 Washer, 3mm Thick	1
<b>Frame</b>				
81	63801-3201	63801-3201	Mechanical Feed Applicator Frame Head	REF
82	63801-3281	63801-3281	Base	REF
83	63801-4550	63801-4550	Track Assembly	REF
<b>Hardware</b>				
91	N/A	N/A	M4 by 10 Lg SHCS	2**
92	N/A	N/A	M4 by 12 Lg SHCS	1**
93	N/A	N/A	M4 by 20 Lg SHCS	4**
94	N/A	N/A	M4 by 40 Lg. SHCS	1**
95	N/A	N/A	M4 by 45 Lg. SHCS	1**
97	N/A	N/A	M8 by 30 Lg. BHCS	1**
98	N/A	N/A	3mm by 6 Lg. Roll Pin	1**

\*\* Available from an industrial supply company such as MSC (1-800-645-7270).

**Note:** Crimp profiles used in 63881-0100 are equivalent to 19287-0115/ASP-M-5QD1087.

Mechanical Feed Metal Strip Applicator

**Assembly Drawing**

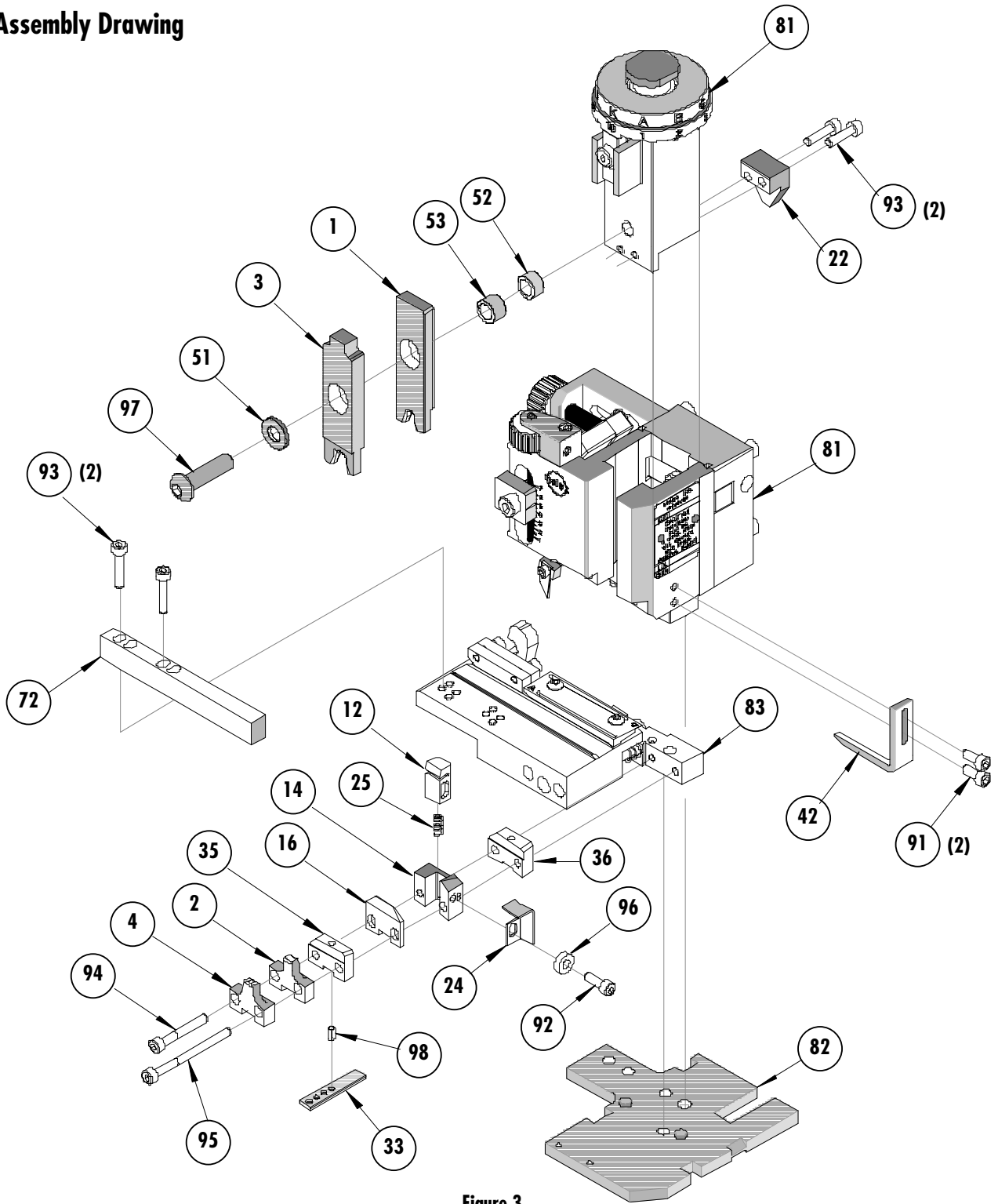

Figure 3

## Mechanical Feed Metal Strip Applicator

### NOTES

1. Molex recommends an extra perishable tooling kit be maintained at your facility.
2. Verify tooling alignment by manually cycling the press with applicator before crimping under power. Check that all screws are tight.
3. Slugs, terminals, dirt, and oil should be kept clear of work area.
4. Wear safety glasses at all times.
5. For recommended maintenance refer to the Mini-Mac Applicator Manual (Document no. 63880-0000).

**CAUTION:** This applicator should only be used in a press with a shut height of 135.80 mm (5.346"). Tooling damage could result at a lower setting.

**CAUTION:** To prevent injury, never operate this applicator without the guards supplied with the press or wire-processing machine in place. Reference the press or wire processing manufacturer's instruction manual.

**CAUTION:** Molex crimp specifications are valid only when used with Molex terminals, applicators and tooling.

### Contact Information

For more information on Molex application tooling please contact Molex at 1-800-786-6539.

#### Molex Application Tooling Group

1150 E. Diehl Road  
Naperville, IL 60563  
Tel: (630) 969-4550  
Fax: (630) 505-0049

Visit our Web site at <http://www.molex.com>