

## **Excellent Integrated System Limited**

Stocking Distributor

Click to view price, real time Inventory, Delivery & Lifecycle Information:

[Molex Connector Corporation](#)  
[0638837200](#)

For any questions, you can email us directly:  
[sales@integrated-circuit.com](mailto:sales@integrated-circuit.com)

Continuous Molded Strip Applicator



**Mini-Mac Applicator  
Application Tooling Specification  
Mechanical Feed - Continuous Molded Strip  
Order No. 63883-7200**

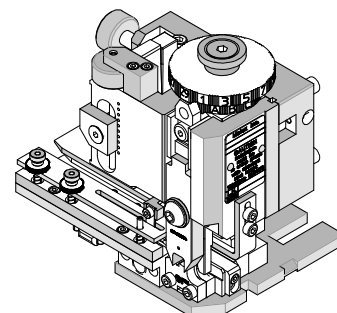

**FEATURES**

- Directly adapts to most crimp presses and automatic wire processors
- Applicator designed to industry-standard mounting and shut height of 135.80mm (5.346")
- Conductor and insulation rings allow quick adjustment for conductor and cut-off tooling height change
- Quick set-up time; plus the crimp height, track and feed adjustments can be set without removing the applicator from the crimp press

**SCOPE**

Products: InsulKrimp™ Quick Disconnect, (FIQD's) Female Terminals for 18-22 AWG.

**Testing**

**Mechanical**

The tensile test, or pull test, is a means of evaluating the mechanical properties of the crimped connections. The following charts show the UL and government specifications (MIL-T-7928) for various wire sizes. The tensile strength is shown in pounds. It indicates the minimum acceptable force to break or separate the terminal from the conductor.

Color Code	Wire Size (AWG)	*UL - 486 A	*UL - 486 C	*UL - 310	*Military Class 2
Yellow	26	3	N/A	N/A	7
Yellow	24	5	N/A	N/A	10
Red	22	8	8	8	15
Red	20	13	10	13	19
Red	18	20	10	20	38
Blue	16	30	15	30	50
Blue	14	50	25	50	70
Yellow	12	70	35	70	110
Yellow	10	80	40	80	150
Red	8	90	45	N/A	225
Blue	6	100	50	N/A	300

\*UL - 486 A - Terminals (Copper conductors only)

\*UL - 486 C - Butt Splices, Parallel Splices, Closed End Connectors, and Wire Nuts

\*UL - 310 - Quick Disconnects, Flag and Couplers

\*Military Class 2- Military Approved Terminals only as listed

Continuous Molded Strip Applicator

**Product List**

The following is a partial list of the product order numbers and their specifications that this tool is designed to run. Updates to this list are available on [www.molex.com](http://www.molex.com).

Terminal No.	Terminal Eng. No.	Wire Size		Insulation Diameter Maximum		Strip Length	
		AWG	mm <sup>2</sup>	mm	In.	mm	In.
19003-0009	AA-2201XC	22-18	0.35-0.80	5.84	.230	6.35	.250
19003-0015	AA-2202XC	22-18	0.35-.080	5.84	.230	6.35	.250
19003-0022	AA-2203XC	22-18	0.35-0.80	5.84	.230	6.35	.250
19003-0028	AA-2204XC	22-18	0.35-0.80	5.84	.230	6.35	.250
19003-0034	AA-2205XC	22-18	0.35-0.80	5.84	.230	6.35	.250

**DEFINITION OF TERMS**

The following illustration is a generic terminal representation and not an exact image of any terminal listed in the scope.

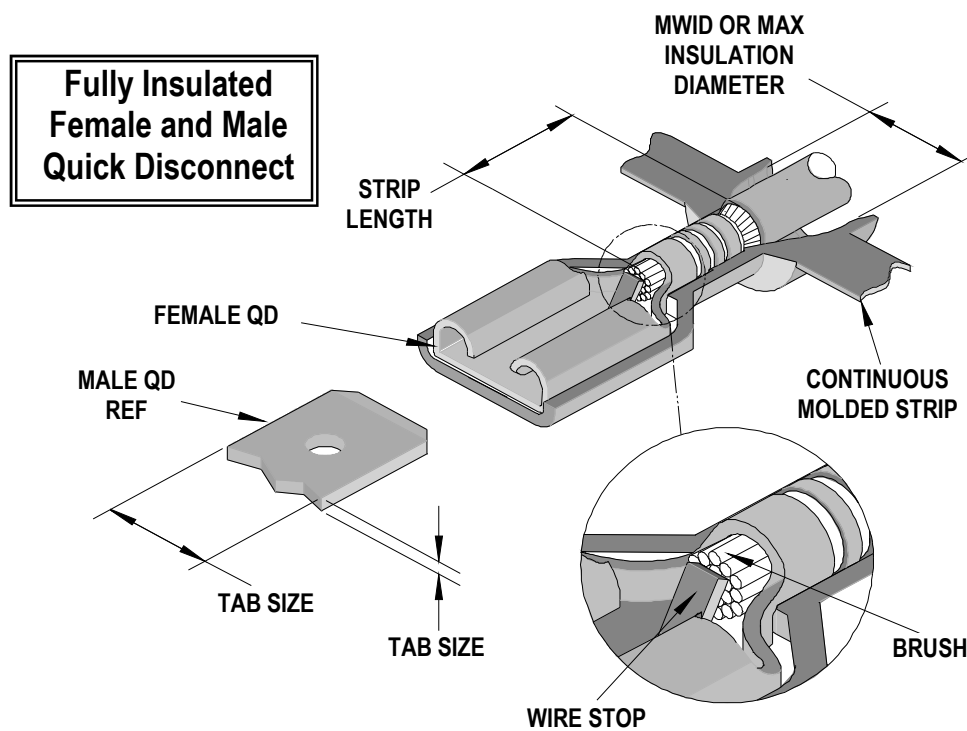

Figure 1

Continuous Molded Strip Applicator

### Tool Calibration

To recalibrate this applicator, make sure the power is completely shut off on the press.

1. The Mini-Mac applicator must be properly installed in the press.
2. Crimping dies must be properly installed in the Mini-Mac applicator.
3. The recommended method of measuring the crimp height of the conductor dies is the soft metal slug method, (See Figure 2).
4. The slug must have a diameter 0.51mm (.020") larger than the "X" No Go dimension before crimping.
5. Place the soft metal slug (solder) into the nest of the bottom die and crimp (by hand cycling the press) similar to a terminal. The crimp height can be measured with a blade type micrometer or dial caliper, (Dimension "X").
6. Adjustment of the crimp height can be accomplished by indexing the conductor cam. The letter "A" gives the loosest position and "K" gives the tightest position. A total adjustment of 0.50mm (.020") can be achieved by adjusting the conductor cam.

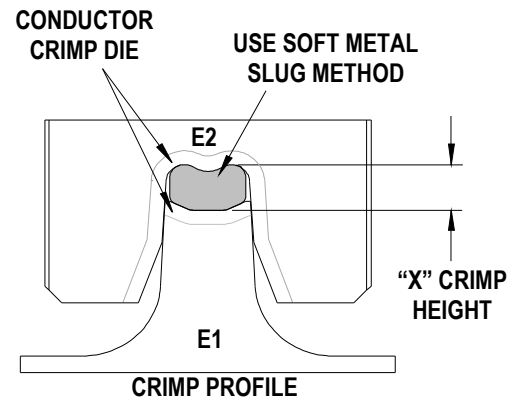

Use soft metal slug (solder) method to measure the "X" dimension. Verify tooling crimp height calibration by referring to the Go/No Go dimensions shown in the chart below.

Figure 2

Note: If the crimp height is too tight on the setting "A", check the shut height of the press. See the Industrial Mini-Mac Applicator Manual Section 2.1 for adjustments.

### CRIMP SPECIFICATIONS

Wire Size		"X" Dimension Conductor Crimp						Pull Force Minimum	
AWG	mm <sup>2</sup>	Mean		Go		No Go		Lbs	N
		In	mm	In	mm	In	mm		
22	0.35	.098	2.45	.095	2.41	.103	2.62	8.0	35.6
20	0.50	.098	2.45	.095	2.41	.103	2.62	13.0	57.8
18	0.80	.098	2.45	.095	2.41	.103	2.62	20.0	90.0

Pull Force should be measured with no influence from the insulation crimp. The above specifications are guidelines to an optimum crimp.

Continuous Molded Strip Applicator

**PARTS LIST**

Mini-Mac Applicator 63883-7200				
Item	Order No	Engineering No.	Description	Quantity
<b>Perishable Tooling</b>				
	<b>63883-7270</b>	<b>63883-7270</b>	<b>Tool Kit (All "Y" Items)</b>	<b>REF</b>
1	63465-0002	63465-0002	Conductor Punch	1 Y
2	63464-0002	63464-0002	Conductor Anvil	1 Y
3	63469-0002	63469-0002	Cut-off Punch	1 Y
4	63462-0043	63462-0043	Cut-off Anvil	1 Y
<b>Other Components (Ref. 30050)</b>				
5	63443-0021	63443-0021	Lower Tooling Key	1
6	63466-0912	63466-0912	Anvil Mount	1
7	63466-0913	63466-0913	Terminal Support	1
8	63466-0921	63466-0921	Terminal Stripping Blade	1
9	63466-0931	63466-0931	Terminal Nose Support	1
10	63600-1290	63600-1290	Washer	1
11	63890-0866	63890-0866	Collar-6.4 Long	1
12	63890-0868	63890-0868	Collar-9.5 Long	1
<b>Frame</b>				
13	63801-3201	63801-3201	Top	1
14	63801-3281	63801-3281	Base	1
15	63801-4450	63801-4450	Track	1
<b>Hardware</b>				
16	N/A	N/A	M3 by 12 Long SHCS	1**
17	N/A	N/A	M4 by 10 Long SHCS	2**
18	N/A	N/A	M4 by 20 Long SHCS	1**
19	N/A	N/A	M4 by 45 Long SHCS	1**
20	N/A	N/A	M5 by 12 Long SHCS	1**
21	N/A	N/A	M8 by 30 Long BHCS	1**
22	N/A	N/A	3mm by 6 Long Roll Pin	1**
** Available from an industrial supply company such as MSC (1-800-645-7270).				

**Note:** Crimp profiles used in 63883-7200 are equivalent to 19030-0072/MMC-AX-205, 19030-0054/MMC-AA-595X, and 19030-0069/MMC-AX-201 (UL file number E79133).

Continuous Molded Strip Applicator

**Assembly Drawing**

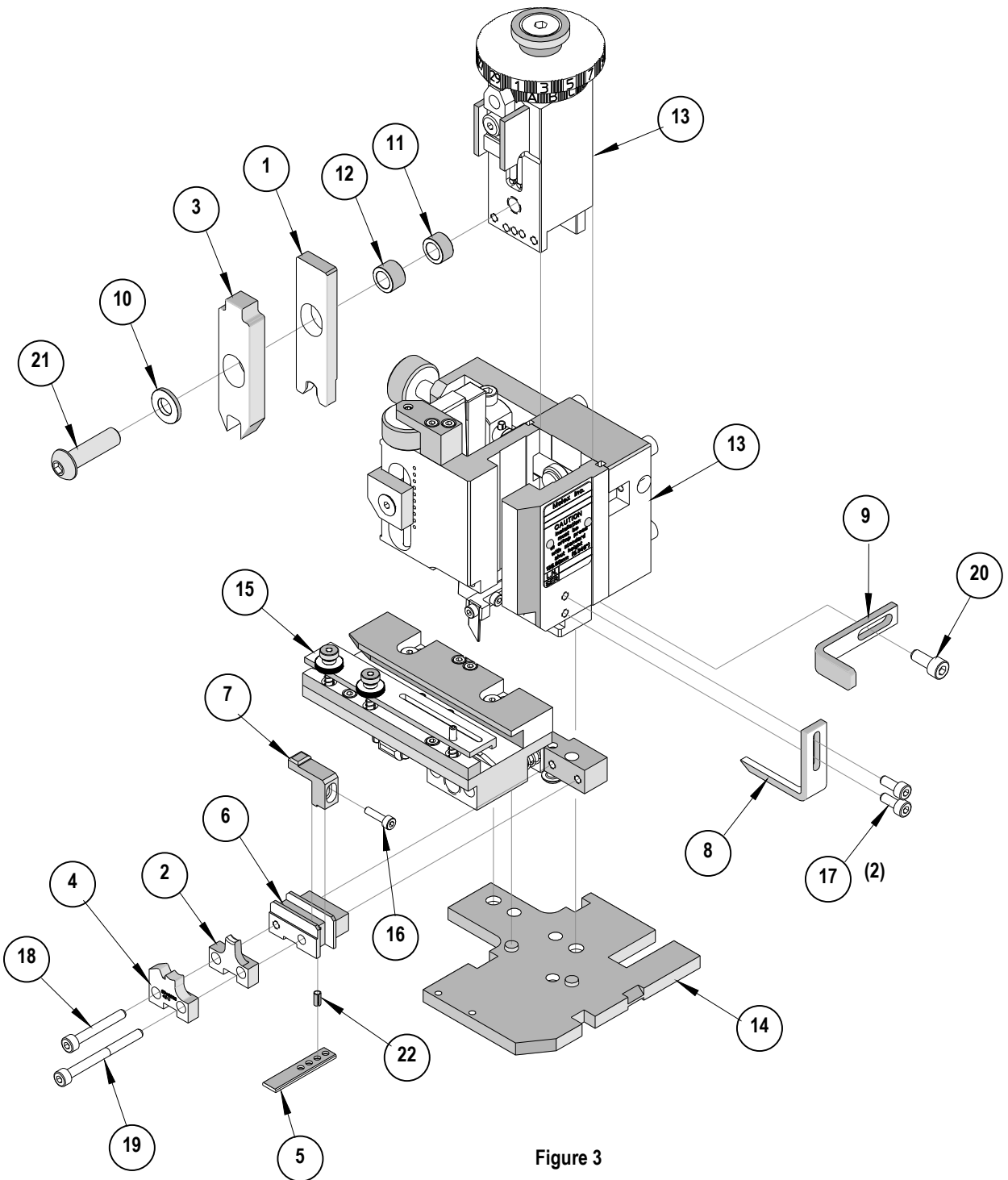

Figure 3

## Continuous Molded Strip Applicator

### NOTES

1. Molex recommends an extra perishable tooling kit be maintained at your facility.
2. Verify tooling alignment by manually cycling the press with applicator before crimping under power. Check that all screws are tight.
3. Slugs, terminals, dirt, and oil should be kept clear of work area.
4. Wear safety glasses at all times.
5. For recommended maintenance refer to the Mini-Mac Applicator Manual (Document no. 63880-0000).

**CAUTION:** This applicator should only be used in a press with a shut height of 135.80 mm (5.346"). Tooling damage could result at a lower setting.

**CAUTION:** To prevent injury, never operate this applicator without the guards supplied with the press or wire-processing machine in place. Reference the press or wire process manufacturer's instruction manual.

**CAUTION:** Molex crimp specifications are valid only when used with Molex terminals, applicators and tooling.

### Contact Information

For more information on Molex application tooling please contact Molex at 1-800-786-6539.

**Americas Headquarters**  
Lisle, Illinois 60532 U.S.A.  
1-800-78MOLEX  
amerinfo@molex.com

**Far East North Headquarters**  
Yamato, Kanagawa, Japan  
81-462-65-2324  
feninfo@molex.com

**Far East South Headquarters**  
Jurong, Singapore  
65-6-268-6868  
fesinfo@molex.com

**European Headquarters**  
Munich, Germany  
49-89-413092-0  
eurinfo@molex.com

**Corporate Headquarters**  
2222 Wellington Ct.  
Lisle, IL 60532 U.S.A.  
630-969-4550  
Fax: 630-969-1352

Visit our Web site at <http://www.molex.com>