

Excellent Integrated System Limited

Stocking Distributor

Click to view price, real time Inventory, Delivery & Lifecycle Information:

[Molex Connector Corporation](#)
[0638935070](#)

For any questions, you can email us directly:

sales@integrated-circuit.com

Mini-Mac Applicator for Disk Drive Power Connection System Terminal



**Mini-Mac Applicator
Specification Sheet
Order No. 63893-5000**

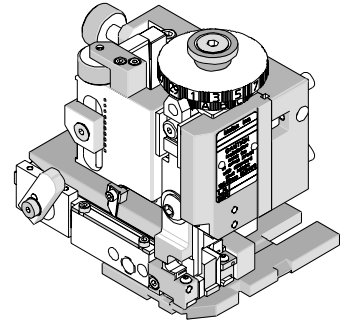

FEATURES

- Directly adapts to most automatic wire processing machines
- Applicator designed to industry standard mounting and shut height 135.80mm (5.346")
- Quick set-up time; plus the crimp height, track and feed adjustments can be set without removing the applicator from the press
- Fine adjustment allows users to achieve target with little effort by adjusting in increments of .015mm (.0006") for conductor crimp height and .063mm (.0025") for insulation height
- Independent adjustment rings allow users to quickly adjust the conductor or insulation crimp height without affecting each other

SCOPE

Products: Disk Drive Power Connection System, Female Crimp Terminal, 18-22 AWG.

Terminal Series No.	Terminal Order No.	Wire Size		Insulation Diameter		Strip Length	
		AWG	mm ²	mm	In.	mm	In.
8980	02-08-1203	18-22	0.80-0.32	1.52-2.29	.060-.090	3.96-5.54	.156-.218
	02-08-1217						
	02-08-1223						

DEFINITION OF TERMS

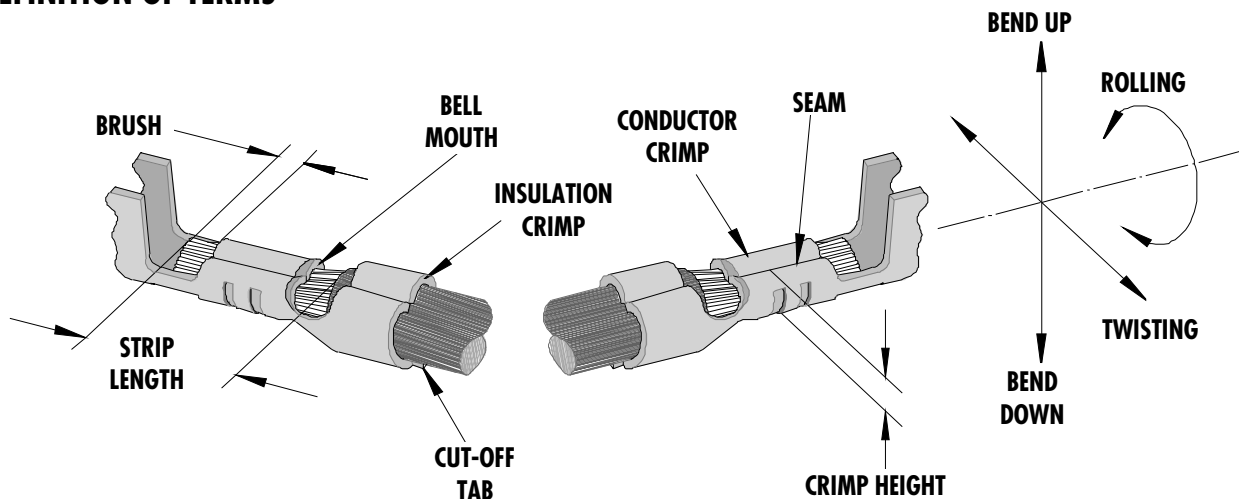

The above terminal drawing is a generic terminal representation. It is not an image of a terminal listed in the scope.

Mini-Mac Applicator for Disk Drive Power Connection System Terminal

CRIMP SPECIFICATIONS

Terminal Series No.	Bell mouth		Cut-off Tab Maximum		Conductor Brush	
	mm	In.	mm	In.	mm	In.
8980						

Terminal Series No.	Bend up	Bend down	Twist	Roll	Punch Width (Ref)				Seam Seam shall not be open and no wire allowed out of the crimping area
	Degree		Degree		Conductor		Insulation		
	mm	In.	mm	In.	mm	In.	mm	In.	
8980					1.70	.067	2.75	.108	

After crimping, the conductor profile should measure the following.

Terminal Series No.	Wire Size		Conductor				Pull Force Minimum	
			Crimp Height		Crimp Width (Ref)			
	AWG	mm ²	mm	In.	mm	In.	N	Lb.
8980	18	0.80	1.19-1.27	.047-.050	1.70	.067	106.8	24.0
	20	0.50	1.04-1.12	.041-.044	1.70	.067	71.2	16.0
	22	0.35	0.94-1.02	.037-.040	1.70	.067	53.4	12.0

NOTE: Some of the specifications in these charts above are intentionally left blank due to the fact that the information does not currently exist.

Pull Force should be measured with no influence from the insulation crimp.

The above specifications are guidelines to an optimum crimp.

Mini-Mac Applicator for Disk Drive Power Connection System Terminal

PARTS LIST

Mini-Mac Applicator 63893-5000				
Item	Order No	Engineering No.	Description	Quantity
Perishable Tooling				
	63893-5070	63893-5070	Tool Kit (All "Y" Items)	REF
1	11-18-5321	60835B06	Conductor Punch	1 Y
2	11-40-5423	63308B07	Conductor Anvil	1 Y
3	11-18-5322	60835B08	Insulation Punch	1 Y
4	11-40-5425	63308B09	Insulation Anvil	1 Y
5	11-40-5426	63308B28	Cut-Off Die Blade	1 Y
6	11-40-5427	63308B29	Cut-Off Plunger	2 Y
Other Components (REF 935050)				
7	11-18-4083	60708-8	Feed Guide	1
8	11-18-4091	60709A108	Rear Plunger Striker	1
9	11-18-4248	60709A115	Terminal Hold Down	1
10	11-18-4619	60752A104	Ejector Spring	1
11	11-18-5319	60835B03	Front Plunger Striker	1
12	11-18-5320	60835B15	Tooling Washer	1
13	11-18-5334	60835B16	Mounting Block	1
14	11-24-1067	4996-4	Compression Spring	2
15	11-40-5413	63308B01	Plunger Retainer	1
16	11-40-5414	63308B02	Spring Retainer	2
17	11-40-5415	63308B04	Rear Plunger Retainer	1
18	11-40-5417	63308B10	Spacer	1
19	63443-0090	63443-0090	Wire Stop	1
20	63443-6115	63443-6115	Cover Rear	1
21	63803-5105	63803-5105	Conductor Bushing	1
Frame				
22	63801-3201	63801-3201	Top	1
23	63801-3282	63801-3282	Base	1
24	63801-6550	63801-6550	Track	1
Hardware				
25	N/A	N/A	M3 by 6 Long SHCS	2**
26	N/A	N/A	M3 by 12 Long BHCS	2**
27	N/A	N/A	M4 by 6 Long SHCS	1**
28	N/A	N/A	M4 by 8 Long BHCS	2**
29	N/A	N/A	M4 by 12 Long BHCS	2**
30	N/A	N/A	M4 by 18 Long SHCS	2**
31	N/A	N/A	M4 by 40 Long SHCS	1**
32	N/A	N/A	M5 by 12 Long SHCS	1**
33	N/A	N/A	M8 by 20 Long BHCS	1**

** Available from an industrial supply company such as MSC (1-800-645-7270).

Mini-Mac Applicator for Disk Drive Power Connection System Terminal

Assembly Drawing

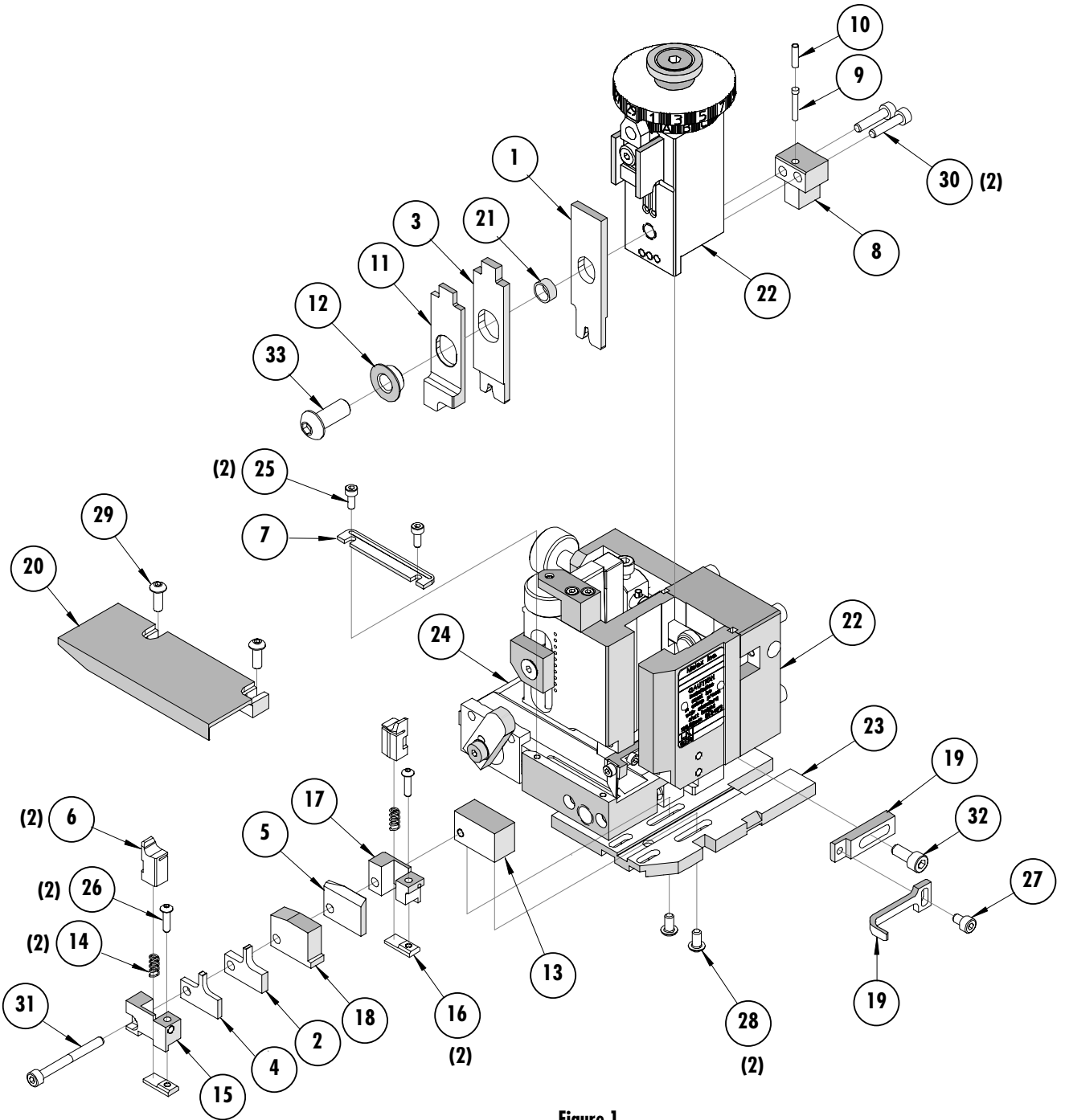

Figure 1

Mini-Mac Applicator for Disk Drive Power Connection System Terminal

NOTES

1. Molex recommends an extra perishable tooling kit be maintained at your facility.
2. Verify tooling alignment by manually cycling the press and applicator before crimping under power. Check that all screws are tight.
3. Slugs, terminals, dirt, and oil should be kept clear of work area.
4. Wear safety glasses at all times.
5. For recommended maintenance refer to the Mini-Mac Manual.

CAUTION: This applicator should only be used in a press with a shut height of 135.80 mm (5.346"). Tooling damage could result at a lower setting

CAUTION: To prevent injury, never operate this applicator without the guards supplied with the press or wire-processing machine in place. Reference the press or wire processing manufacturer's instruction manual.

CAUTION: Molex crimp specifications are valid only when used with Molex terminals, applicators and tooling.

Contact Information

For more information on Molex application tooling please contact Molex at 1-800-786-6539.

Americas Headquarters

Lisle, Illinois 60532 U.S.A.
1-800-78MOLEX
amerinfo@molex.com

Far East North Headquarters

Yamato, Kanagawa, Japan
81-462-65-2324
feninfo@molex.com

Far East South Headquarters

Jurong, Singapore
65-6-268-6868
fesinfo@molex.com

European Headquarters

Munich, Germany
49-89-413092-0
eurinfo@molex.com

Corporate Headquarters

2222 Wellington Ct.
Lisle, IL 60532 U.S.A.
630-969-4550
Fax: 630-969-1352

Visit our Web site at <http://www.molex.com>