

Excellent Integrated System Limited

Stocking Distributor

Click to view price, real time Inventory, Delivery & Lifecycle Information:

[Diodes Incorporated](#)
[ZDS1009TA](#)

For any questions, you can email us directly:

sales@integrated-circuit.com



ZDS1009

SM-8 COMPLEMENTARY CURRENT MIRROR

DESCRIPTION

The ZDS1009 current mirror has been developed specifically for high side, current sense plus level translation applications and as such will find a broad applications base including battery charge management, DC motor control and over current monitoring functions. It is of particular interest for current sense applications for feedback purposes in fast battery chargers for Li-Ion cell based systems.

The device functions by sensing the voltage developed across an external (user defined) high side current sense resistor, and by an arrangement of current mirrors refer this sensed voltage, with or without multiplication, to a low side referenced signal. This signal can then be used, for example, to close the control loop to a controller IC, for a DC-DC converter providing charge to a battery.

FEATURES

- Excellent Temperature Tracking Characteristics
- Compact Cost Effective Solution
- Simplifies Circuit Implementation
- Broad application base from Single Cell Li-ion High Side Current sense chargers to Multi-cell Lead-Acid systems
- Only 4 Connections required

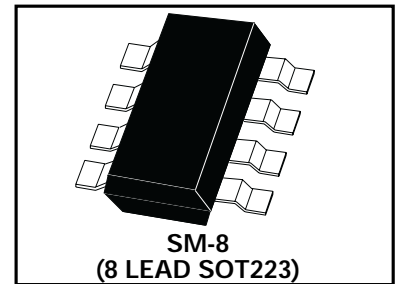

SCHEMATIC DIAGRAM

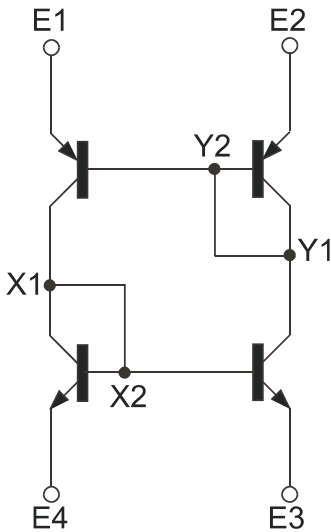

CONNECTION DIAGRAM

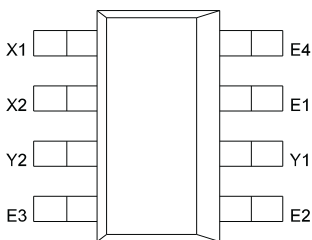

TYPICAL APPLICATION CIRCUIT

$$V_{\text{sense}} = I R_2 \frac{R_4}{R_1}$$

For balance $R_3=R_4$

eg

$$R_2=100\text{m}\Omega$$

$$R_1=R_3=R_4=100\Omega$$

$$V_{\text{sense}} \text{ sensitivity} = 100\text{mV/A}$$

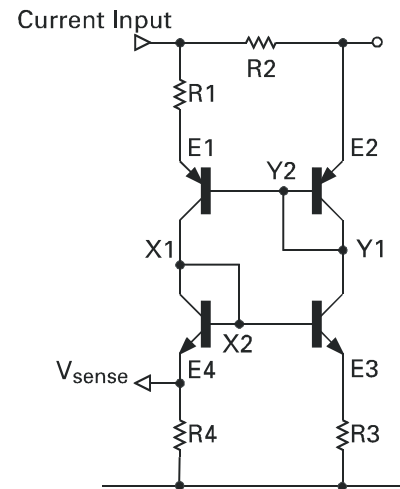

ZDS1009

ABSOLUTE MAXIMUM RATINGS.

PARAMETER	SYMBOL	VALUE	UNIT
Maximum Operating Voltage	V_{y1-x1}	120	V
Maximum Voltage (E1-E2,E3-E4)	$V_{E-E'}$	10	V
Peak Pulse Current	I_M	4	A
Continuous Current (E1-E4,E2-E3)	I_C	1	A
Total Power Dissipation at $T_{amb} = 25^{\circ}C^*$	P_{tot}	2	W
Operating and Storage Temperature Range	$T_j; T_{stg}$	-55 to +150	$^{\circ}C$

* The power which can be dissipated assuming the device is mounted in a typical manner on a PCB with copper equal to 2 inches square.

ELECTRICAL CHARACTERISTICS (at $T_{amb}=25^{\circ}C$)

Parameter	Symbol	Min	Max	Unit	Conditions
Breakdown Voltage	BV_{Y1-X1}	120		V	$I_{Y1}=100\mu A$
Breakdown Voltage	BV_{X1-E1}	-30		V	$I_{X1}=-10mA$
Breakdown Voltage	BV_{Y1-E3}	30		V	$I_{Y1}=10mA$
Breakdown Voltage	BV_{E1-Y1}	-12		V	$I_{E1}=-100\mu A$
Breakdown Voltage	BV_{E2-Y1}	-6		V	$I_{E2}=-100\mu A$
Breakdown Voltage	BV_{E3-X1}	12		V	$I_{E3}=100\mu A$
Breakdown Voltage	BV_{E4-X1}	6		V	$I_{E4}=100\mu A$
Leakage	I_{Y1}		50	nA	$V_{Y1-X1}=100V$
Leakage	I_{X1}		-10	μA	$V_{X1-E1}=-30V, V_{Y1}=V_{E1}$
Leakage	I_{Y1}		10	μA	$V_{Y1-E3}=30V, V_{X1}=V_{E3}$
Leakage	I_{E1}		-100	nA	$V_{E1-Y1}=-8V$
Leakage	I_{E2}		-100	nA	$V_{E2-Y1}=-4V$
Leakage	I_{E3}		100	nA	$V_{E3-X1}=8V$
Leakage	I_{E4}		100	nA	$V_{E4-X1}=4V$
Input Voltage	V_{Y1-E2}	-1.45	-1.65	V	$I_{Y1}=-1A$
Input Voltage	V_{Y1-E3}	1.45	1.75	V	$I_{Y1}=1A, V_{X1}=V_{Y1}$
Input Voltage	V_{X1-E1}	-1.45	-1.75	V	$I_{X1}=-1A, V_{X1}=V_{Y1}$
Input Voltage	V_{X1-E4}	1.45	1.65	V	$I_{X1}=1A$
Transfer Characteristic	V_{OUT}	0.99	1.01	V	See Fig 1. $V_{CC}=5V$ $R1=R3=R4=100\Omega, V_{IN}=1V$
Transfer Characteristic	V_{OUT}	1		mV	See Fig 1. $V_{CC}=5V$ $R1=R3=R4=100\Omega, V_{IN}=5mV$
Output Zero-Offset Voltage	V_{OFFSET}		4	mV	See Fig 2. $V_{CC}=5V, R2<1\Omega$ $R1=R3=R4=100\Omega$

ZDS1009

TYPICAL CHARACTERISTICS

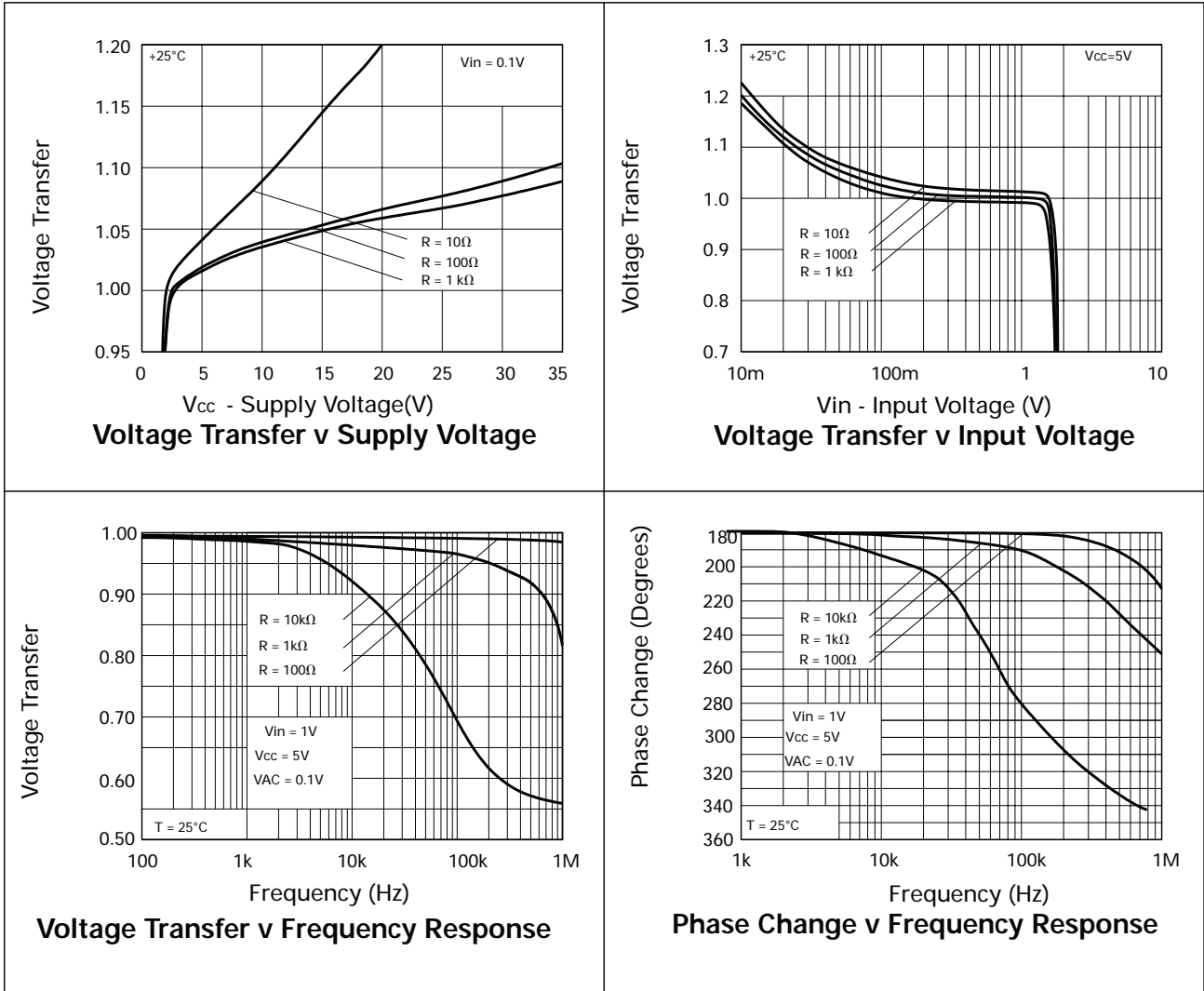

TEST CIRCUITS

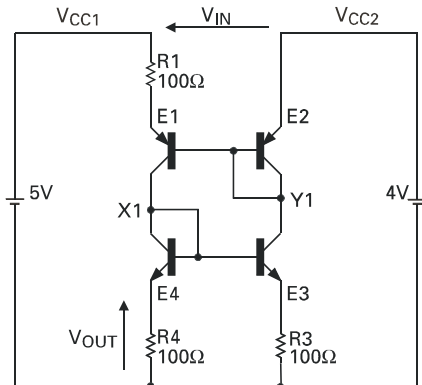

Figure 1
Transfer Characteristic Test Circuit

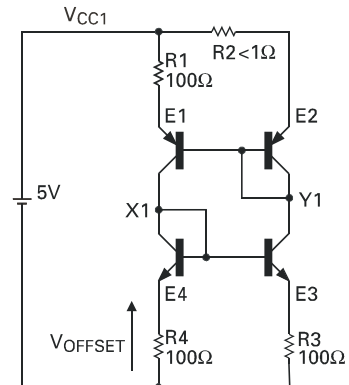
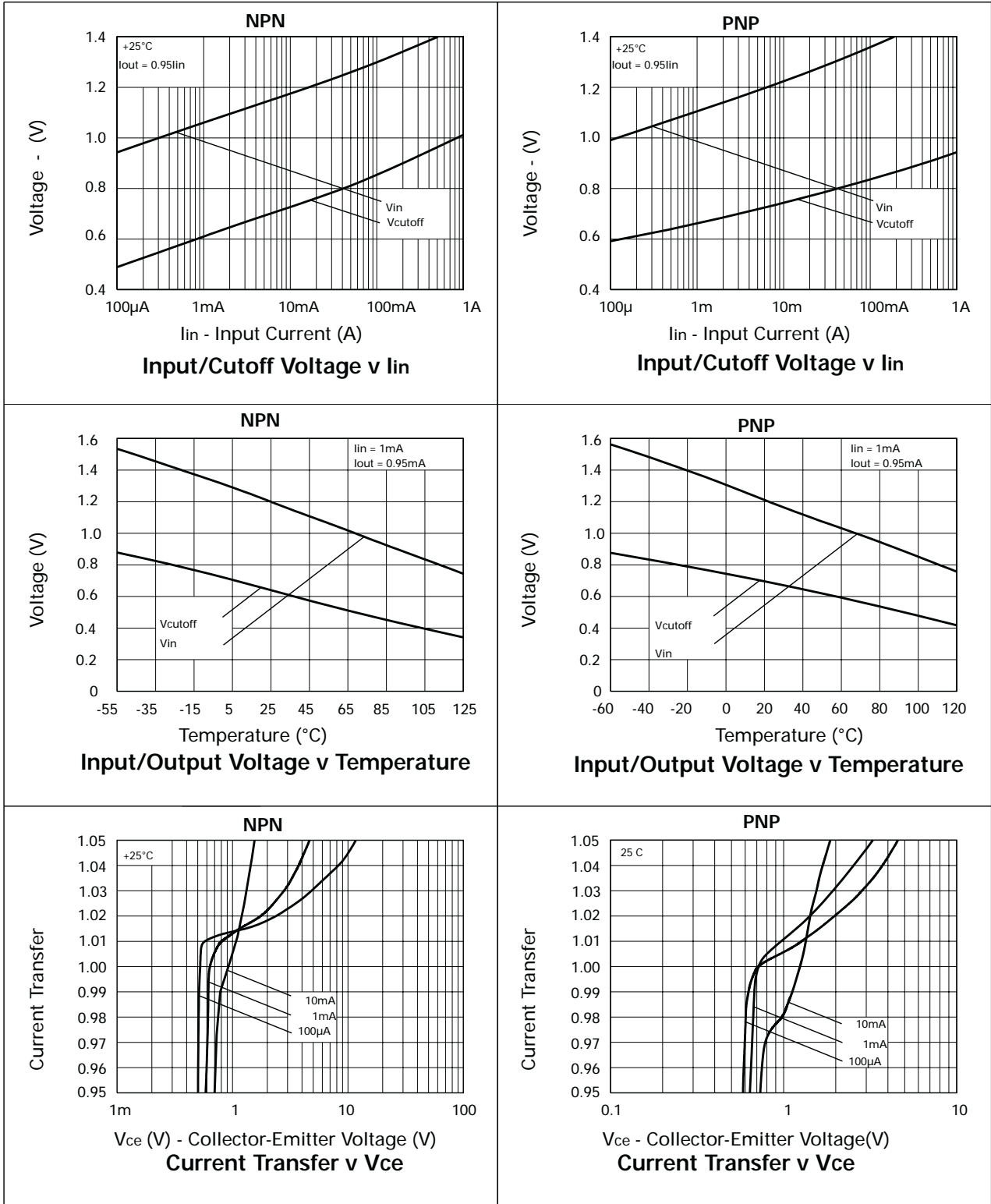

Figure 2
Output Zero-Offset Voltage Test Circuit

ZDS1009

TYPICAL CHARACTERISTICS



ZDS1009

PACKAGE DIMENSIONS

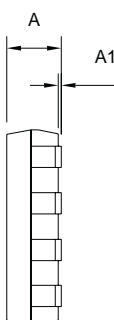
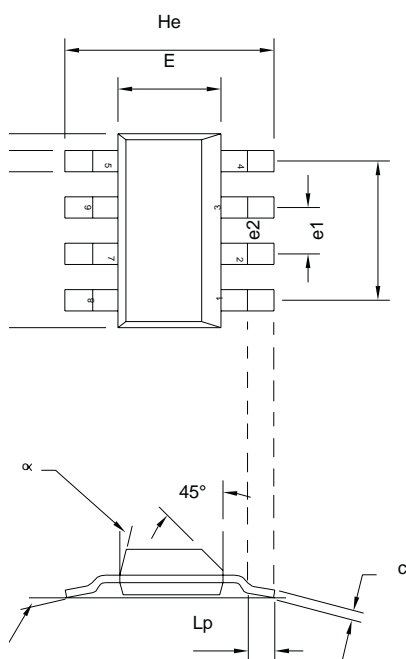

DIM	Millimetres			Inches		
	Min	Typ	Max	Min	Typ	Max
A	-	-	1.7	-	-	0.067
A1	0.02	-	0.1	0.0008	-	0.004
b	-	0.7	-	-	0.028	-
c	0.24	-	0.32	0.009	-	0.013
D	6.3	-	6.7	0.248	-	0.264
E	3.3	-	3.7	0.130	-	0.145
e1	-	4.59	-	-	0.180	-
e2	-	1.53	-	-	0.060	-
He	6.7	-	7.3	0.264	-	0.287
Lp	0.9	-	-	0.035	-	-
α	-	-	15°	-	-	15°
β	-	10°	-	-	10°	-

ORDERING INFORMATION

DEVICE	PARTMARKING
ZDS1009	S1009



Zetex plc.
 Fields New Road, Chadderton, Oldham, OL9 8NP, United Kingdom.
 Telephone: (44)161 622 4422 (Sales), (44)161 622 4444 (General Enquiries)
 Fax: (44)161 622 4420

Zetex GmbH
 Streitfeldstraße 19
 D-81673 München
 Germany
 Telefon: (49) 89 45 49 49 0
 Fax: (49) 89 45 49 49 49

Zetex Inc.
 47 Mall Drive, Unit 4
 Commack NY 11725
 USA
 Telephone: (631) 543-7100
 Fax: (631) 864-7630

Zetex (Asia) Ltd.
 3510 Metroplaza, Tower 2
 Hing Fong Road,
 Kwai Fong, Hong Kong
 Telephone: (852) 26100 611
 Fax: (852) 24250 494

These are supported by
 agents and distributors in
 major countries world-wide
 © Zetex plc 2000

Internet <http://www.zetex.com>

This publication is issued to provide outline information only which (unless agreed by the Company in writing) may not be used, applied or reproduced for any purpose or form part of any order or contract or be regarded as a representation relating to the products or services concerned. The Company reserves the right to alter without notice the specification, design, price or conditions of supply of any product or service.

