

Excellent Integrated System Limited

Stocking Distributor

Click to view price, real time Inventory, Delivery & Lifecycle Information:

[C&K Components](#)
[RS-022R05C1-PA](#)

For any questions, you can email us directly:

sales@integrated-circuit.com

附表

FORCE (gf)	KNOB COLOR	Operating Life With Load
A	GREY	100,000 Cycles
H	WHITE	
0	GREY	
1	BLACK C/RED	50,000 Cycles
3	IVORY	

L	
A	3.15
B	3.85
C	5.85
D	8.35
E	6.85
F	6.15
G	12.35
H	11.35

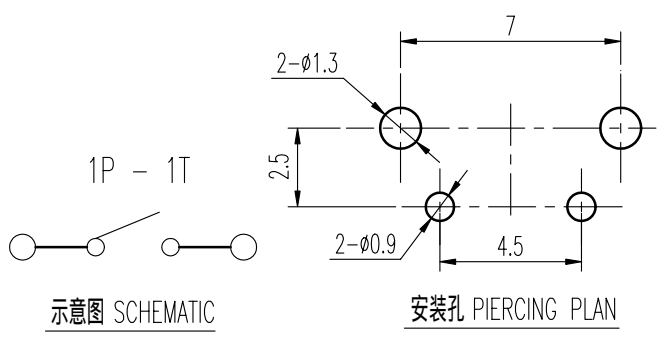
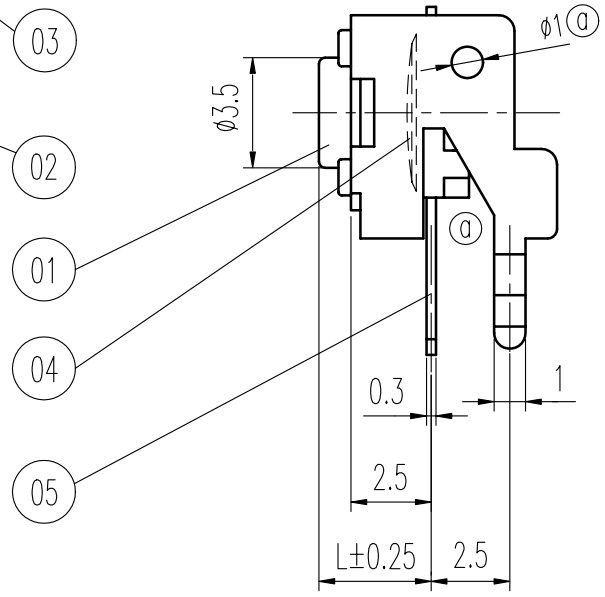
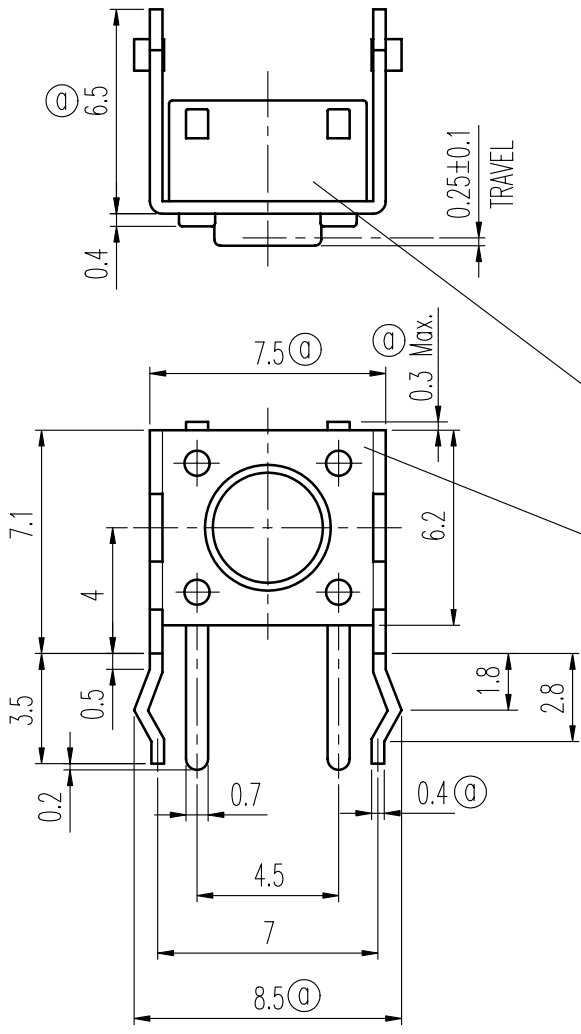

规格 Specifications

额定负荷 Ratings	DC 12 V 50 mA
初期接触电阻 Initial Contact Resistance	100 mΩ Max.
绝缘电阻 Insulation Resistance	DC 100 V 60±5 Sec. 100 MΩ Min.
抗电强度 Dielectric Voltage	AC 250 V(50~60HZ) 60±5 Sec.
操作力 Operating Force	见附表
负荷寿命 Operating Life With Load	见附表

序NO.	零件 PART	材料 MATERIAL	数量 QTY	备注 REMARKS	标号 REV	内容 DESCRIPTION	签名 SIGN.	日期 DATE
05	端子 TERMINAL	C2680R	2	Ag PLATED				
04	弹片 SPRING PLATE	C5210R	1	Ag CLAD				
03	胶壳 HOUSING	PA	1	BLACK C	A02	变更盖片厚度、形状及相关尺寸,见①	张渠江	2009-12-21
02	盖片 COVER	SPTe	1	NATURAL	A01		张渠江	2009-8-10
01	胶柄 KNOB	PA	1	见附表				
					DWG NO. ITEM3114			

TOLERANCES UNLESS OTHERWISE SPEC.		TITLE	TACT SWITCH		ITEM NO	RS-022R05__-PA		
UNDER 1	± 0.10	DRAWN	张渠江	2009-12-21	VERSION	A02	PAGE	1 OF 1
1 - 10	± 0.30	REVIEWED	王光云	2009-12-21	SCALE		UNIT	mm
OVER 10	± 0.50	APPROVED	马建和	2009-12-21	PROJECTION			