

Excellent Integrated System Limited

Stocking Distributor

Click to view price, real time Inventory, Delivery & Lifecycle Information:

[Honeywell Sensing and Productivity Solutions](#)
[V3L-3052](#)

For any questions, you can email us directly:

sales@integrated-circuit.com

MICRO SWITCH

FREEDPORT ILLINOIS, U.S.A
 A DIVISION OF HONEYWELL
 FED. MFG. CODE 91829

SWITCH-BASIC

CATALOG LISTING

V3L-3052

CQ-X1863

V3L-3052

REPLACES X48216 - V3L

RELEASE NO. PR-2659

M

DRAWING NUMBER

X 7

ISSUE

X 7

CHECK

REVISIONS

A	CO31198	JAH	8 NOV 72
B	CO55729	KEW	5 SEP 84
C	CO 30987	SMA	1 OCT 89
D	CO71543	JAS	6 FEB 91
E	CO 72552	DHD	2 SEP 92
F	CO 76232	DCS	9 NOV 93

CHECK

19 MAY 72

LS D

72

MAY

WIB

D B

FO-52848

DRAWN

.19 DIA X .19 WIDE OIL BRONZE ROLLER (CONCENTRICITY .005 TIR)

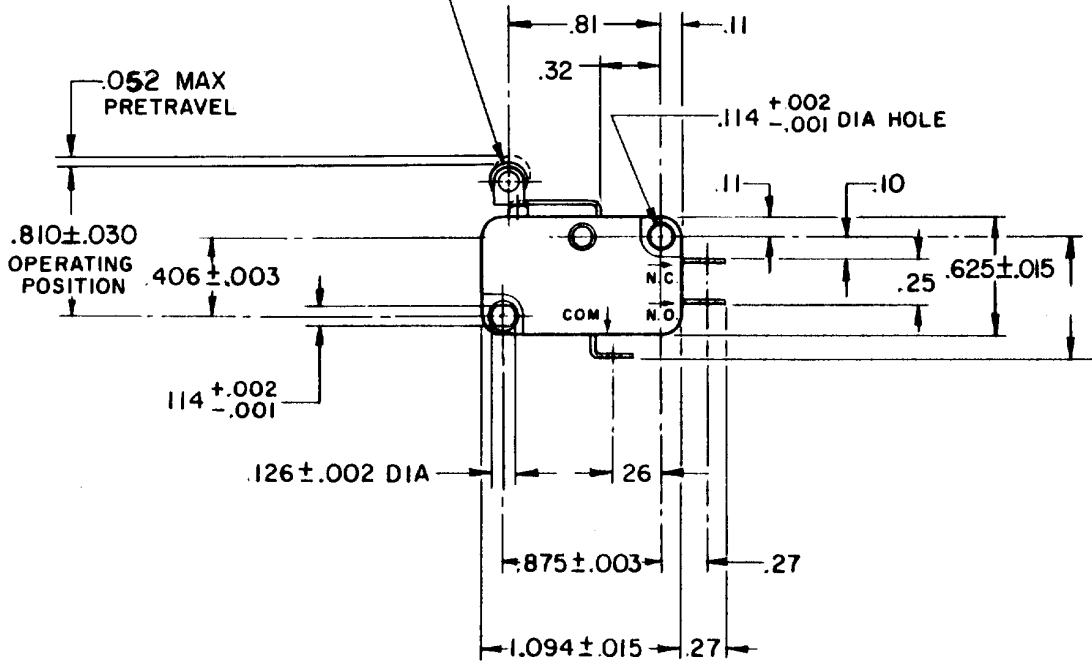
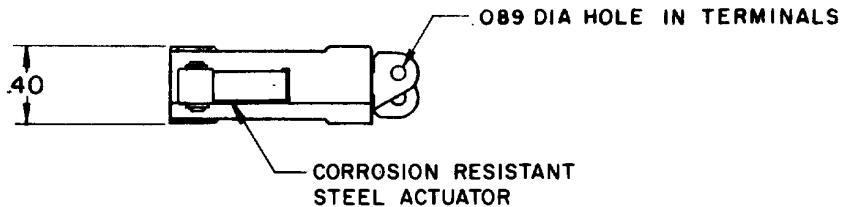

NOTES

- 1 SWITCH MATERIALS WILL WITHSTAND TEMPERATURE OF 300° F
- 2 CAUTION: OVERTRAVEL FORCE ON LEVER MUST NOT RESULT IN AN OVERTRAVEL FORCE ON PLUNGER EXCEEDING FIVE POUNDS
- 3 TERMINALS ARE PLATED FOR SOLDERING

THIS DRAWING COVERS A PROPRIETARY ITEM AND IS THE PROPERTY OF MICRO SWITCH, A DIVISION OF HONEYWELL. THIS DRAWING IS NOT TO BE COPIED OR USED WITHOUT THE APPROVAL OF MICRO SWITCH.

CHARACTERISTICS	ELECTRICAL DATA	SCALE FULL	
OPERATING FORCE - - - - - 180 GRAM MAX	CONTACT ARRANGEMENT S P D T	DO NOT SCALE PRINT	
RELEASE FORCE - - - - - 15 GRAM MIN	15.1A 1/2HP 125 OR 250 VAC 1/2A 125 VDC, 1/4A 250 VDC 5A 125 VAC "L" 	UNLESS OTHERWISE NOTED	
DIFFERENTIAL TRAVEL - - - - .012 MAX		DIMENSIONS ARE IN INCHES TOLERANCES ARE ONE PLACE (.0) ± .030 TWO PLACE (.00) ± .015 THREE PLACE (.000) ± .005 ANGLES ±	
OVERTRAVEL - - - - - .032 MIN			WEIGHT
RELEASE TRAVEL - - - - - .007 MIN			