

Excellent Integrated System Limited

Stocking Distributor

Click to view price, real time Inventory, Delivery & Lifecycle Information:

[Texas Instruments](#)
[TPS65053IRGERQ1](#)

For any questions, you can email us directly:

sales@integrated-circuit.com

5-CHANNEL POWER MGMT IC WITH TWO STEP DOWN CONVERTERS AND 3 LOW-INPUT VOLTAGE LDOs

Check for Samples: [TPS65053-Q1](#), [TPS650531-Q1](#), [TPS650532-Q1](#)

FEATURES

- Qualified for Automotive Applications
- Up To 95% Efficiency
- Output Current for DC/DC Converters:
 - TPS65053-Q1 : DCDC1 = 1 A; DCDC2 = 0.6 A
 - TPS650531-Q1 : DCDC1 = 1 A; DCDC2 = 1 A
 - TPS650532-Q1: DCDC1 = 1 A; DCDC2 = 1 A
- DC/DC Converters Externally Adjustable
- V_{IN} Range for DC/DC Converters From 2.5 V to 6 V
- 2.25-MHz Fixed Frequency Operation
- Power Save Mode at Light Load Current
- 180° Out-of-Phase Operation
- Output Voltage Accuracy in PWM Mode $\pm 1\%$
- Total Typical 32- μ A Quiescent Current for Both DC/DC Converters
- 100% Duty Cycle for Lowest Dropout
- One General-Purpose 400-mA LDO
- Two General-Purpose 200-mA LDOs
- V_{IN} Range for LDOs from 1.5 V to 6.5 V
- Output Voltage for LDO3:
 - TPS65053-Q1 : VLDO3 = 1.3 V
 - TPS650531-Q1 : VLDO3 = 1.2 V
 - TPS650532-Q1: VLDO3 = 1.5 V
- Available in a 4 mm x 4 mm 24-Pin QFN Package

DESCRIPTION

The TPS65053x are integrated Power Management ICs for applications powered by one Li-Ion or Li-Polymer cell, which require multiple power rails. The TPS65053x provide two highly efficient, 2.25MHz step-down converters targeted at providing the core voltage and I/O voltage in a processor based system. Both step-down converters enter a low power mode at light load for maximum efficiency across the widest possible range of load currents. For low noise applications the devices can be forced into fixed frequency PWM mode by pulling the MODE pin high. Both converters allow the use of small inductors and capacitors to achieve a small solution size. TPS65053-Q1 provides an output current of up to 1A on the DCDC1 converter and up to 0.6A on the DCDC2 converter. TPS650531-Q1 and TPS650532-Q1 provide up to 1A on both DCDC1 and DCDC2. The TPS65053x also integrate one 400mA LDO and two 200mA LDO voltage regulators, which can be turned on/off using separate enable pins on each LDO. Each LDO operates with an input voltage range between 1.5V and 6.5V allowing them to be supplied from one of the step-down converters or directly from the main battery. LDO1 and LDO2 are externally adjustable while LDO3 has a fixed output voltage of 1.3V on TPS65053-Q1, 1.2V on TPS650531-Q1 and 1.5V on TPS650532-Q1.

The TPS65053x come in a small 24-pin leadless package (4mm x 4mm QFN) with a 0,5mm pitch.

ORDERING INFORMATION⁽¹⁾

T _A	PACKAGE	OUTPUT VOLTAGE ON LDO3	ORDERABLE PART NUMBER	TOP-SIDE MARKING
-40°C to 85°C	QFN - RGE	1.3V	TPS650531RGERQ1	65053Q
		1.2V	TPS6505311RGERQ1	PREVIEW
		1.5V	TPS6505321RGERQ1	PREVIEW

(1) For the most current package and ordering information, see the *Package Option Addendum* at the end of this document, or see the TI web site at www.ti.com.



Please be aware that an important notice concerning availability, standard warranty, and use in critical applications of Texas Instruments semiconductor products and disclaimers thereto appears at the end of this data sheet.

PowerPAD is a trademark of Texas Instruments.



This integrated circuit can be damaged by ESD. Texas Instruments recommends that all integrated circuits be handled with appropriate precautions. Failure to observe proper handling and installation procedures can cause damage.

ESD damage can range from subtle performance degradation to complete device failure. Precision integrated circuits may be more susceptible to damage because very small parametric changes could cause the device not to meet its published specifications.

ABSOLUTE MAXIMUM RATINGS

over operating free-air temperature range (unless otherwise noted)⁽¹⁾

		UNITS
V _I	Input voltage range on all pins except AGND, PGND, and EN_LDO1 pins with respect to AGND	–0.3 V to 7 V
	Input voltage range on EN_LDO1 pin with respect to AGND	–0.3 V to V _{CC} + 0.5 V
I _I	Current at VINDCDC1/2, L1, PGND1, L2, PGND2	1800 mA
	Current at all other pins	1000 mA
V _O	Output voltage range for LDO1, LDO2 and LDO3	–0.3 V to 4.0 V
T _A	Operating free-air temperature	–40°C to 85°C
T _{stg}	Storage temperature range	–65°C to 150°C

(1) Stresses beyond those listed under *absolute maximum ratings* may cause permanent damage to the device. These are stress ratings only and functional operation of the device at these or any other conditions beyond those indicated under *recommended operating conditions* is not implied. Exposure to absolute-maximum-rated conditions for extended periods may affect device reliability.

DISSIPATION RATINGS

PACKAGE	R _{θJA} (1)	T _A ≤ 25°C POWER RATING	DERATING FACTOR ABOVE T _A = 25°C	T _A = 70°C POWER RATING	T _A = 85°C POWER RATING
RGE	35 K/W	2.8 W	28 mW/K	1.57 W	1.14 W

(1) The thermal resistance junction to case of the RGE package is 2 K/W measured on a high K board.

RECOMMENDED OPERATING CONDITIONS

		MIN	NOM	MAX	UNIT
V _{INDCDC1/2}	Input voltage range for step-down converters	2.5		6	V
V _{DCDC1}	Output voltage range for VDCDC1 step-down converter	0.6		V _{INDCDC1}	V
V _{DCDC2}	Output voltage range for VDCDC2 step-down converter	0.6		V _{INDCDC2}	V
V _{INLDO1} , V _{INLDO2/3}	Input voltage range for LDOs	1.5		6.5	V
V _{LDO1-2}	Output voltage range for LDO1 and LDO2	1		3.6	V
V _{LDO3}	Output voltage for LDO3 on TPS65053-Q1		1.3		V
	Output voltage for LDO3 on TPS650531-Q1		1.2		
	Output voltage for LDO3 on TPS650532-Q1		1.5		
I _{OUTDCDC1}	Output current at L1			1000	mA
L1	Inductor at L1 ⁽¹⁾	1.5	2.2		μH
C _{INDCDC1/2}	Input capacitor at V _{INDCDC1/2} ⁽¹⁾	22			μF
C _{OUTDCDC1}	Output capacitor at V _{DCDC1} ⁽¹⁾	10	22		μF
I _{OUTDCDC2}	Output current at L2 for TPS65053-Q1			600	mA
	Output current at L2 for TPS650531-Q1, TPS650532-Q1			1000	
L2	Inductor at L2 ⁽¹⁾	1.5	2.2		μH
C _{OUTDCDC2}	Output capacitor at V _{DCDC2} ⁽¹⁾	10	22		μF
C _{VCC}	Input capacitor at VCC ⁽¹⁾	1			μF
C _{in1-2}	Input capacitor at VINLDO1, VINLDO2/3 ⁽¹⁾	2.2			μF
C _{OUT1}	Output capacitor at VLDO1 ⁽¹⁾	4.7			μF
C _{OUT2-3}	Output capacitor at VLDO2-3 ⁽¹⁾	2.2			μF
I _{LDO1}	Output current at VLDO1			400	mA
I _{LDO2,3}	Output current at VLDO2,3			200	mA

(1) See the *Application Information* section of this data sheet for more details.

RECOMMENDED OPERATING CONDITIONS (continued)

		MIN	NOM	MAX	UNIT
T _A	Operating ambient temperature range	-40		85	°C
T _J	Operating junction temperature range	-40		125	°C
R _{CC}	Resistor from battery voltage to V _{CC} used for filtering ⁽²⁾		1	10	Ω

(2) Up to 2 mA can flow into V_{CC} when both converters are running in PWM, this resistor causes the UVLO threshold to be shifted accordingly.

ELECTRICAL CHARACTERISTICS

V_{CC} = VINDCDC1/2 = 3.6V, EN = V_{CC}, MODE = GND, L = 2.2μH, C_{OUT} = 22μF, T_A = -40°C to 85°C typical values are at T_A = 25°C (unless otherwise noted).

PARAMETER		TEST CONDITIONS	MIN	TYP	MAX	UNIT	
SUPPLY CURRENT							
V _{CC}	Input voltage range		2.5		6	V	
I _Q	Operating quiescent current Total current into V _{CC} : VINDCDC1/2, VINLDO1, VINLDO2/3	One converter, I _{OUT} = 0 mA, PFM mode enabled (Mode = GND) device not switching, EN_DCDC1 = Vin OR EN_DCDC2 = Vin; EN_LDO1 = EN_LDO2 = EN_LDO3 = GND		20	30	μA	
		Two converters, I _{OUT} = 0 mA, PFM mode enabled (Mode = 0) device not switching, EN_DCDC1 = Vin AND EN_DCDC2 = Vin; EN_LDO1 = EN_LDO2 = EN_LDO3 = GND		32	40	μA	
		One converter, I _{OUT} = 0 mA, PFM mode enabled (Mode = GND) device not switching, EN_DCDC1 = Vin OR EN_DCDC2 = Vin; EN_LDO1 = EN_LDO2 = EN_LDO3 = Vin		145	210	μA	
I _Q	Operating quiescent current into V _{CC}	One converter, I _{OUT} = 0 mA, Switching with no load (Mode = Vin), PWM operation EN_DCDC1 = Vin OR EN_DCDC2 = Vin; EN_LDO1 = EN_LDO2 = EN_LDO3 = GND		0.85		mA	
		Two converters, I _{OUT} = 0 mA, Switching with no load (Mode = Vin), PWM operation EN_DCDC1 = Vin AND EN_DCDC2 = Vin; EN_LDO1 = EN_LDO2 = EN_LDO3 = GND		1.25		mA	
I _(SD)	Shutdown current	EN_DCDC1 = EN_DCDC2 = GND EN_LDO1 = EN_LDO2 = EN_LDO3 = GND		9	12	μA	
UVLO	Undervoltage lockout threshold for DCDC converters and LDOs	Voltage at V _{CC}		1.8	2	V	
EN_DCDC1, EN_DCDC2, EN_LDO1, EN_LDO2, EN_LDO3, MODE							
V _{IH}	High-level input voltage	MODE, EN_DCDC1, EN_DCDC2, EN_LDO1, EN_LDO2, EN_LDO3	1.2		V _{CC}	V	
V _{IL}	Low-level input voltage	MODE, EN_DCDC1, EN_DCDC2, EN_LDO1, EN_LDO2, EN_LDO3	0		0.4	V	
I _{IN}	Input bias current	MODE, EN_DCDC1, EN_DCDC2, EN_LDO1, EN_LDO2, EN_LDO3, MODE = GND or VIN		0.01	1	μA	
POWER SWITCH							
r _{DS(on)}	P-channel MOSFET on resistance	DCDC1, DCDC2	VINDCDC1/2 = 3.6 V	280	630	mΩ	
			VINDCDC1/2 = 2.5 V	400			
I _{LD_P MOS}	P-channel leakage current		V _(DS) = 6 V		1	μA	
r _{DS(on)}	N-channel MOSFET on resistance	DCDC1, DCDC2	VINDCDC1/2 = 3.6 V	220	450	mΩ	
			VINDCDC1/2 = 2.5 V	320			
I _{LK_N MOS}	N-channel leakage current		V _(DS) = 6 V	7	10	μA	
I _(LIMF)	Forward Current Limit PMOS (High-Side) and NMOS (Low side)	DCDC1	2.5 V ≤ V _{IN} ≤ 6 V	1.1	1.4	1.8	A
		DCDC2 (TPS65053-Q1)		0.85	1	1.15	
		DCDC2 (TPS650531-Q1, TPS650532-Q1)		1.19	1.4	1.65	
T _{SD}	Thermal shutdown			150		°C	
	Thermal shutdown hysteresis			20		°C	

ELECTRICAL CHARACTERISTICS (continued)

$V_{CC} = V_{INDCDC1/2} = 3.6V$, $EN = V_{CC}$, MODE = GND, $L = 2.2\mu H$, $C_{OUT} = 22\mu F$, $T_A = -40^\circ C$ to $85^\circ C$ typical values are at $T_A = 25^\circ C$ (unless otherwise noted).

PARAMETER		TEST CONDITIONS	MIN	TYP	MAX	UNIT	
OSCILLATOR							
f_{SW}	Oscillator frequency		2.025	2.25	2.475	MHz	
OUTPUT							
V_{OUT}	Output voltage range		0.6		V_{IN}	V	
V_{ref}	Reference voltage			600		mV	
V_{OUT}	DC output voltage accuracy	DCDC1, DCDC2 ⁽¹⁾	$V_{IN} = 2.5 V$ to $6 V$, Mode = GND, PFM operation, $0 mA < I_{OUT} < I_{OUTMAX}$		-2%	0	2%
			$V_{IN} = 2.5 V$ to $6 V$, Mode = V_{IN} , PWM operation, $0 mA < I_{OUT} < I_{OUTMAX}$		-1%	0	1%
ΔV_{OUT}	Power save mode ripple voltage ⁽²⁾	$I_{OUT} = 1 mA$, Mode = GND, $V_O = 1.3 V$, Bandwidth = 20 MHz		25		mV _{PP}	
t_{start}	Start-up time	Time from active EN to Start switching		170		μs	
t_{ramp}	V_{OUT} Ramp up Time	Time to ramp from 5% to 95% of V_{OUT}		750		μs	
	RESET delay time	Input voltage at threshold pin rising	80	100	120	ms	
V_{OL}	RESET output low voltage	$I_{OL} = 1 mA$, $V_{threshold} < 1 V$			0.2	V	
	RESET sink current			1		mA	
	RESET output leakage current	$V_{threshold} > 1 V$		10		nA	
V_{th}	Threshold voltage	falling voltage	0.98	1	1.02	V	
V_LDO1, V_LDO2, V_LDO3 LOW DROPOUT REGULATORS							
V_{INLDO}	Input voltage range for LDO1, LDO2, LDO3		1.5		6.5	V	
V_{LDO1}	LDO1 output voltage range		1		3.6	V	
V_{LDO2}	LDO2 output voltage range		1		3.6	V	
V_{LDO3}	LDO3 output voltage for TPS65053-Q1			1.3		V	
	LDO3 output voltage for TPS650531-Q1			1.2			
	LDO3 output voltage for TPS650532-Q1			1.5			
$V_{(FB)}$	Feedback voltage for FB_LDO1, FB_LDO2			1		V	
I_O	Maximum output current for LDO1		400			mA	
	Maximum output current for LDO2, LDO3		200			mA	
$I_{(SC)}$	LDO1 short-circuit current limit	$V_{LDO1} = GND$			850	mA	
	LDO2 & LDO3 short-circuit current limit	$V_{LDO2} = GND$, $V_{LDO3} = GND$			420	mA	
	Dropout voltage at LDO1	$I_O = 400 mA$, $V_{INLDO1} = 1.8 V$			280	mV	
	Dropout voltage at LDO2, LDO3	$I_O = 200 mA$, $V_{INLDO2/3} = 1.8 V$			280	mV	
	Output voltage accuracy for LDO1, LDO2, LDO3 ⁽¹⁾	$I_O = 10 mA$	-2%		1%		
	Line regulation for LDO1, LDO2, LDO3	$V_{INLDO1,2} = V_{LDO1,2} + 0.5 V$ (min. 2.5 V) to 6.5V, $I_O = 10 mA$	-1%		1%		
	Load regulation for LDO1, LDO2, LDO3	$I_O = 0 mA$ to 400 mA for LDO1 $I_O = 0 mA$ to 200 mA for LDO2, LDO3	-1%		1%		
	Regulation time for LDO1, LDO2, LDO3	Load change from 10% to 90%		25		μs	
$R_{(DIS)}$	Internal discharge resistor at V_LDO1, V_LDO2, V_LDO3	Active when LDO is disabled		350		Ω	
	Thermal shutdown	Increasing junction temperature		140		$^\circ C$	
	Thermal shutdown hysteresis	Decreasing junction temperature		20		$^\circ C$	

(1) Output voltage specification does not include tolerance of external voltage programming resistors.

(2) In Power Save Mode, operation is typically entered at $I_{PSM} = V_{IN} / 32 \Omega$.

PIN ASSIGNMENTS

RGE PACKAGE (TOP VIEW)

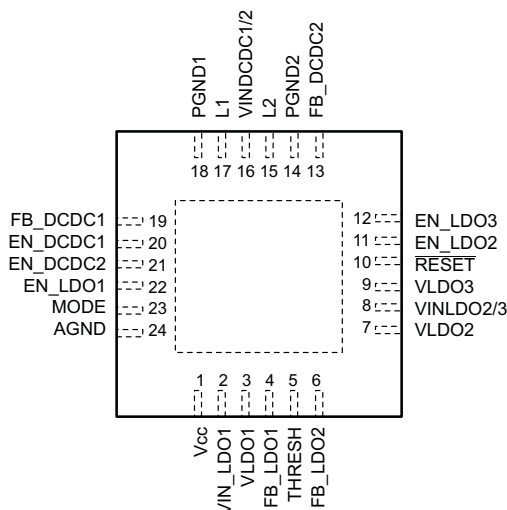

PIN FUNCTIONS

PIN		I/O	DESCRIPTION
NAME	NO.		
V _{CC}	1	I	Power supply for digital and analog circuitry of DCDC1, DCDC2 and LDOs. This pin must be connected to the same voltage supply as VINDCDC1/2.
FB_DCDC1	19	I	Input to adjust output voltage of converter 1 between 0.6 V and V _I . Connect external resistor divider between VOUT1, this pin and GND.
MODE	23	I	Select between Power Save Mode and forced PWM Mode for DCDC1 and DCDC2. In Power Save Mode, PFM is used at light loads, PWM for higher loads. If PIN is set to high level, forced PWM Mode is selected. If Pin has low level, then the device operates in Power Save Mode.
VINDCDC1/2	16	I	Input voltage for VDCDC1 and VDCDC2 step-down converter. This must be connected to the same voltage supply as V _{CC} .
FB_DCDC2	13	I	Input to adjust output voltage of converter 2 between 0.6V and VIN. Connect external resistor divider between VOUT2, this pin and GND.
L1	17	O	Switch pin of converter 1. Connected to Inductor
PGND1	18	I	GND for converter 1
PGND2	14	I	GND for converter 2
AGND	24	I	Analog GND, connect to PGND and PowerPAD™
L2	15	O	Switch Pin of converter 2. Connected to Inductor.
EN_DCDC1	20	I	Enable Input for converter 1, active high
EN_DCDC2	21	I	Enable Input for converter 2, active high
VINLDO1	2	I	Input voltage for LDO1
VINLDO2/3	8	I	Input voltage for LDO2 and LDO3
VLDO1	3	O	Output voltage of LDO1
VLDO2	7	O	Output voltage of LDO2
VLDO3	9	O	Output voltage of LDO3
FB_LDO1	4	I	Feedback input for the external voltage divider.
FB_LDO2	6	I	Feedback input for the external voltage divider.
EN_LDO1	22	I	Enable input for LDO1. Logic high enables the LDO, logic low disables the LDO.
EN_LDO2	11	I	Enable input for LDO2. Logic high enables the LDO, logic low disables the LDO.
EN_LDO3	12	I	Enable input for LDO3. Logic high enables the LDO, logic low disables the LDO.
THRESHOLD	5	I	Reset input
RESET	10	O	Open drain active low reset output, 100 ms reset delay time.
PowerPAD™	–		Connect to GND

TPS65053-Q1
TPS650531-Q1
TPS650532-Q1



SLVSAW1 – JUNE 2011

www.ti.com

FUNCTIONAL BLOCK DIAGRAM

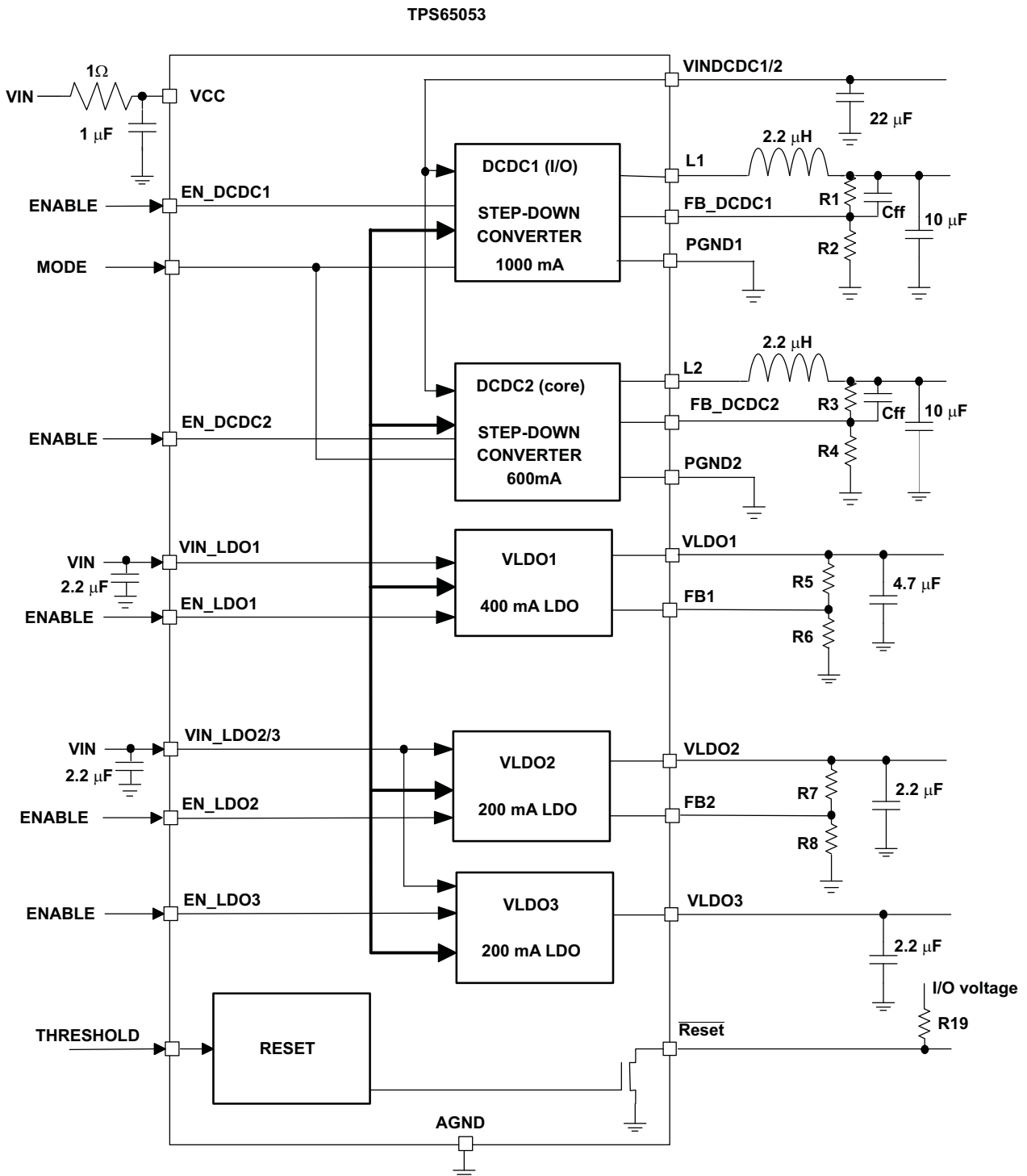

TYPICAL CHARACTERISTICS

Table of Graphs

			FIGURE
η	Efficiency converter 1	vs Load current PWM/PFM mode	1
η	Efficiency converter 1	vs Load current PWM mode	2
η	Efficiency converter 2	vs Load current PWM/PFM mode	3
η	Efficiency converter 2	vs Load current PWM mode	4
	Output voltage ripple in PFM mode	Scope plot	5
	Output voltage ripple in PWM mode	Scope plot	6
	DCDC1, DCDC2, LDO1 startup timing	Scope plot	7
	LDO1 to LDO3 startup timing	Scope plot	8
	DCDC1 Load transient response in PWM mode	Scope plot	9
	DCDC1 Load transient response in PFM mode	Scope plot	10
	DCDC2 Load transient response in PWM mode	Scope plot	11
	DCDC2 Load transient response in PFM mode	Scope plot	12
	DCDC1 Line transient response in PWM mode	Scope plot	13
	DCDC2 Line transient response in PWM mode	Scope plot	14
	LDO1 Load transient response	Scope plot	15
	LDO3 Load transient response	Scope plot	16
	LDO1 Line transient response	Scope plot	17
	LDO1 Power supply rejection ratio	vs frequency	18

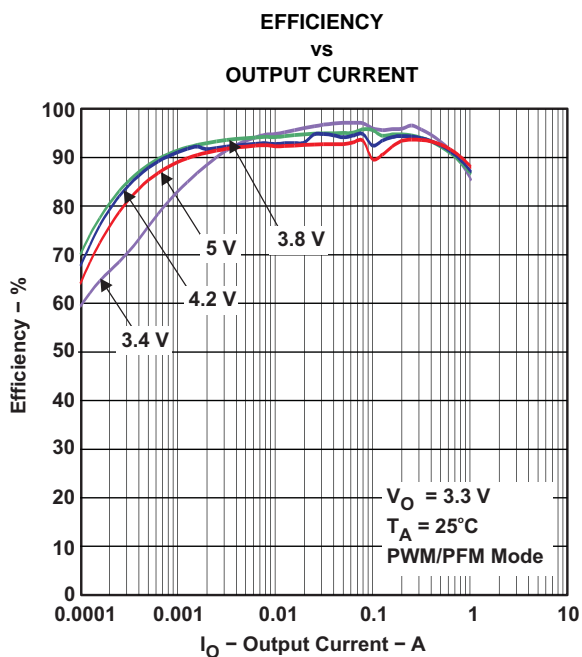

Figure 1.

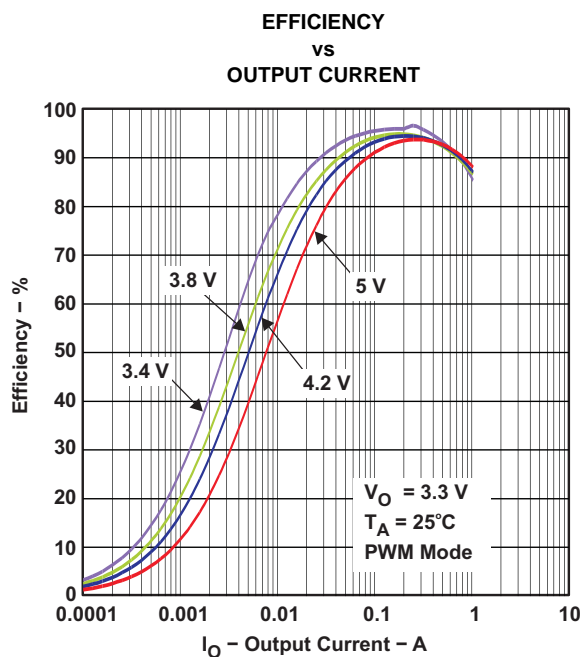

Figure 2.

TYPICAL CHARACTERISTICS (continued)

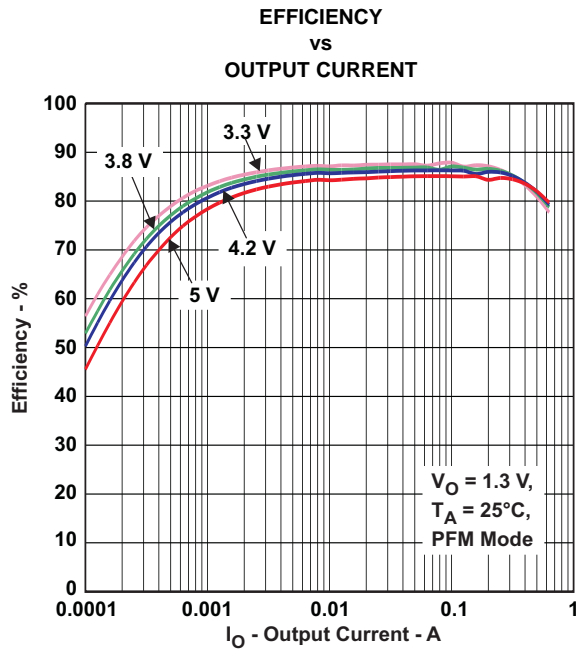

Figure 3.

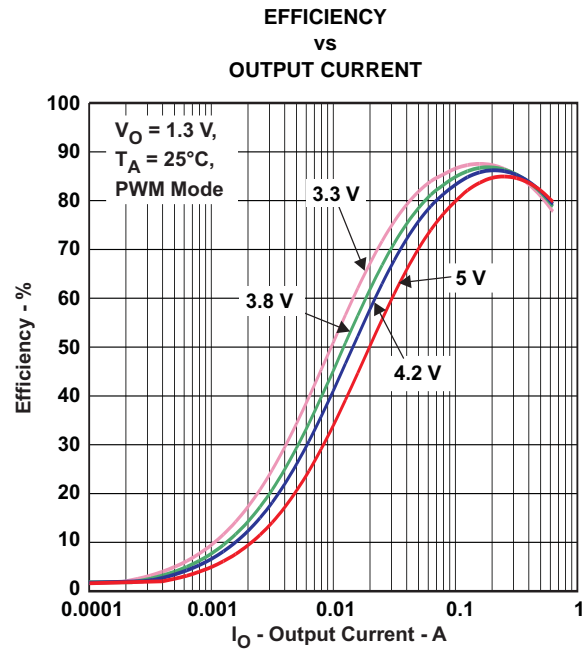

Figure 4.

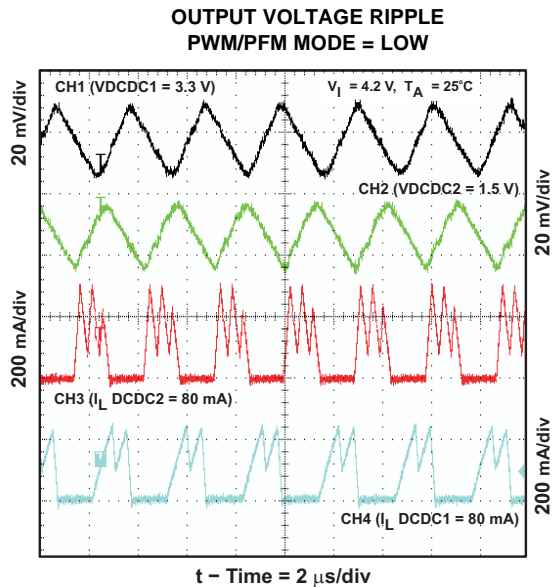

Figure 5.

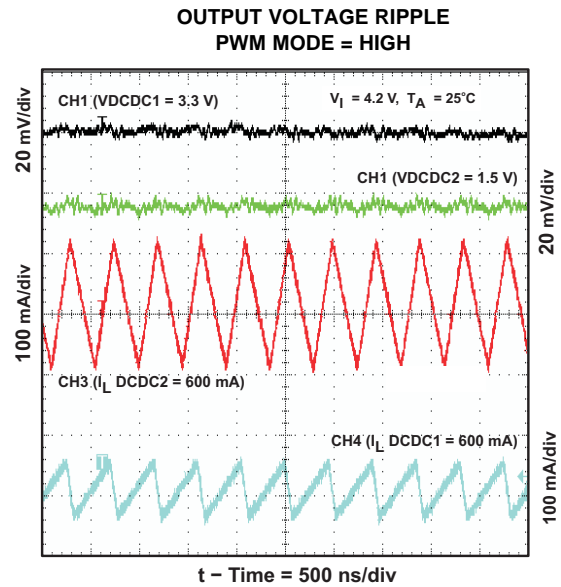

Figure 6.

TYPICAL CHARACTERISTICS (continued)

DCDC1 STARTUP TIMING

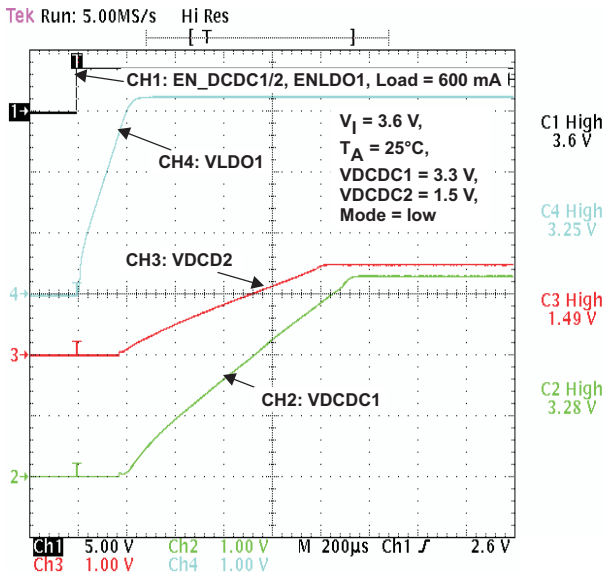

Figure 7.

LDO1 TO LDO3 STARTUP TIMING

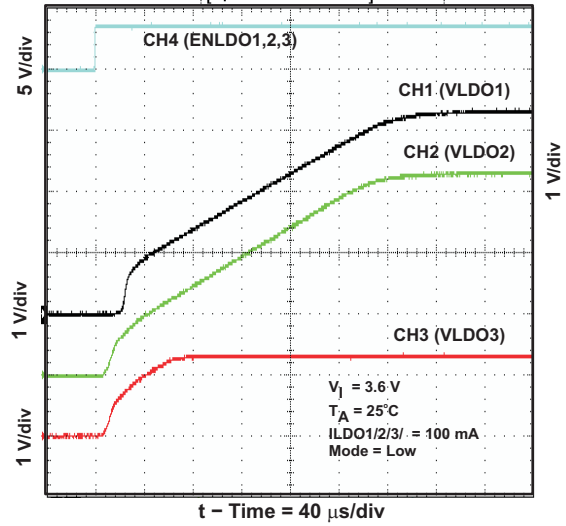

Figure 8.

DCDC1 LOAD TRANSIENT RESPONSE

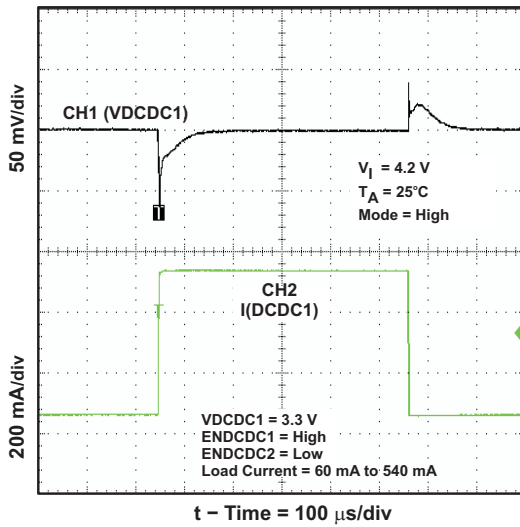

Figure 9.

DCDC1 LOAD TRANSIENT RESPONSE

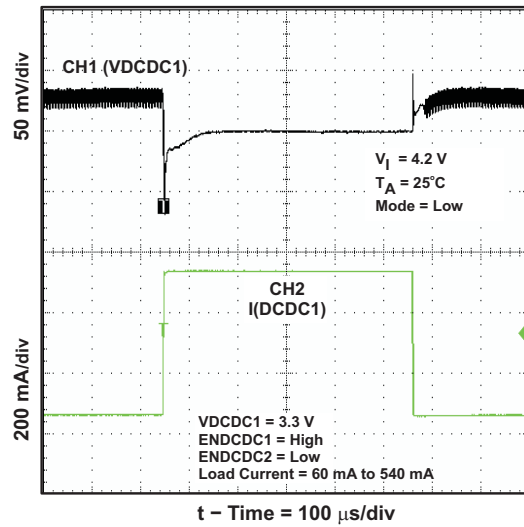
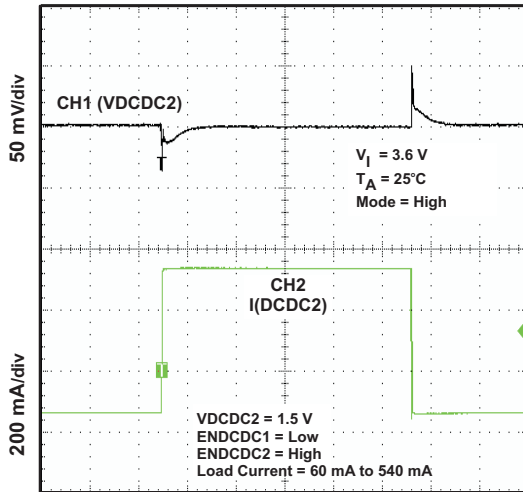

Figure 10.

TYPICAL CHARACTERISTICS (continued)

DCDC2 LOAD TRANSIENT RESPONSE



t – Time = 100 μ s/div

Figure 11.

DCDC2 LOAD TRANSIENT RESPONSE

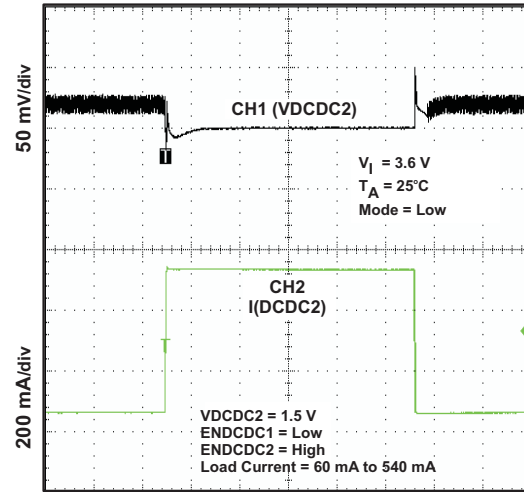

t – Time = 100 μ s/div

Figure 12.

DCDC1 LINE TRANSIENT RESPONSE

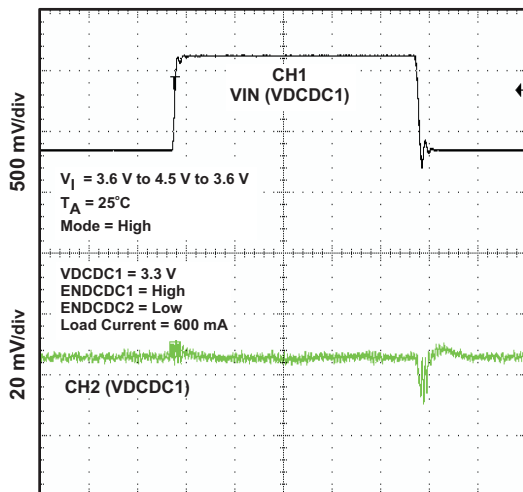

t – Time = 100 μ s/div

Figure 13.

DCDC2 LINE TRANSIENT RESPONSE

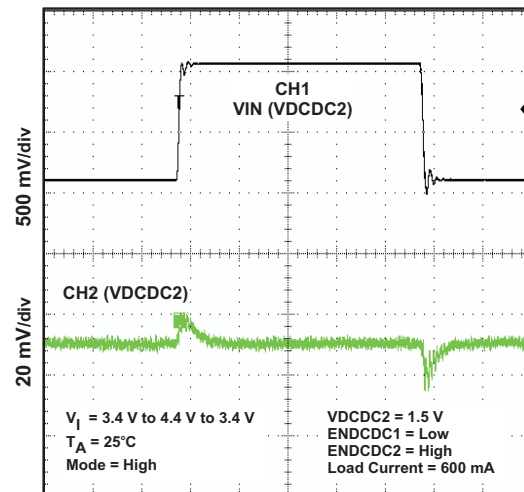

t – Time = 100 μ s/div

Figure 14.

TYPICAL CHARACTERISTICS (continued)

LDO1 LOAD TRANSIENT RESPONSE

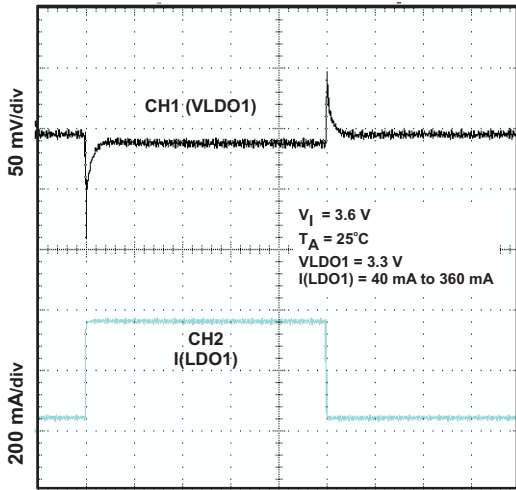

t – Time = 200 μ s/div

Figure 15.

LDO3 LOAD TRANSIENT RESPONSE

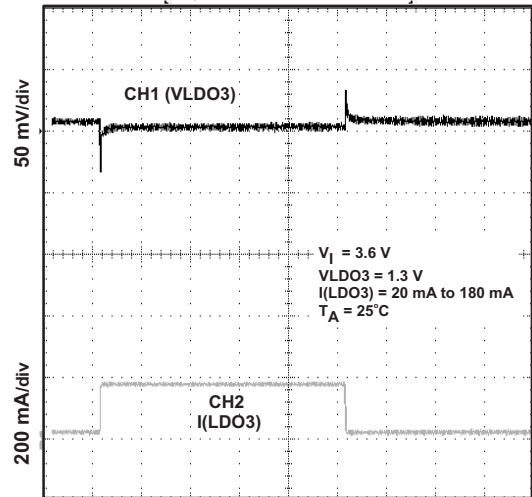

t – Time = 100 μ s/div

Figure 16.

LDO1 LINE TRANSIENT RESPONSE

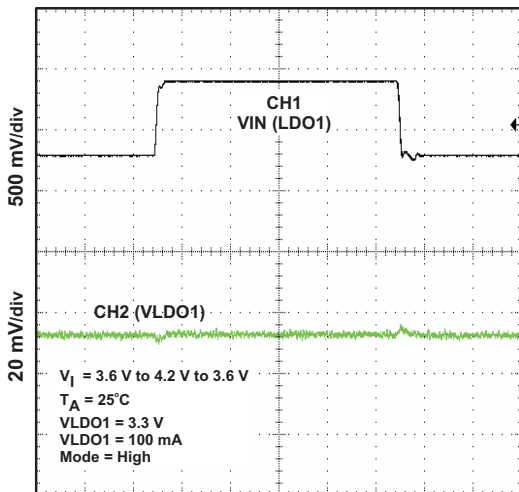

t – Time = 100 μ s/div

Figure 17.

**LDO1 POWER SUPPLY REJECTION RATIO
vs
FREQUENCY**

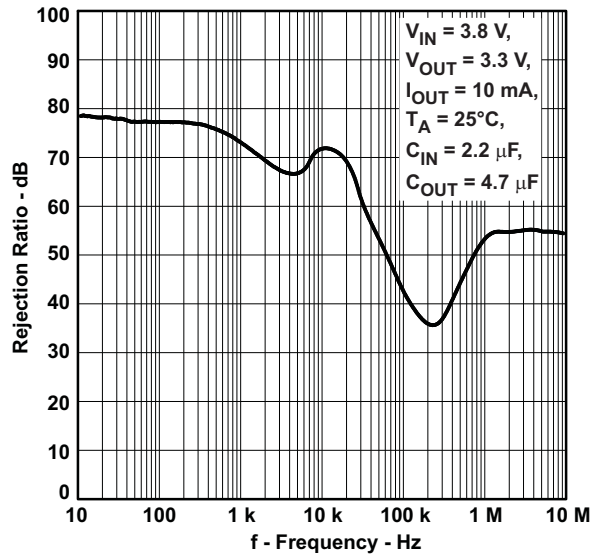

Figure 18.

DETAILED DESCRIPTION

OPERATION

The TPS65053x include two synchronous step-down converters. The converters operate with 2.25MHz fixed frequency pulse width modulation (PWM) at moderate to heavy load currents. At light load currents the converters automatically enter Power Save Mode and operate with PFM (Pulse Frequency Modulation).

During PWM operation the converters use a unique fast response voltage mode controller scheme with input voltage feed-forward to achieve good line and load regulation allowing the use of small ceramic input and output capacitors. At the beginning of each clock cycle initiated by the clock signal, the P-channel MOSFET switch is turned on and the inductor current ramps up until the comparator trips and the control logic turns off the switch. The current limit comparator will also turn off the switch in case the current limit of the P-channel switch is exceeded. After the adaptive dead time prevents shoot through current, the N-channel MOSFET rectifier is turned on and the inductor current ramps down. The next cycle is initiated by the clock signal again turning off the N-channel rectifier and turning on the P-channel switch.

The two DC-DC converters operate synchronized to each other, with converter 1 as the master. A 180° phase shift between Converter 1 and Converter 2 decreases the input RMS current. Therefore smaller input capacitors can be used.

The converters output voltage is set by an external resistor divider connected to FB_DCDC1 or FB_DCDC2, respectively. See application section for more details.

POWER SAVE MODE

The Power Save Mode is enabled with Mode Pin set to low. If the load current decreases, the converters will enter Power Save Mode operation automatically. During Power Save Mode the converters operate with reduced switching frequency in PFM mode and with a minimum quiescent current to maintain high efficiency. The converter will position the output voltage typically 1% above the nominal output voltage. This voltage positioning feature minimizes voltage drops caused by a sudden load step.

In order to optimize the converter efficiency at light load the average current is monitored and if in PWM mode the inductor current remains below a certain threshold, then Power Save Mode is entered. The typical threshold can be calculated according to:

Equation 1: Average output current threshold to enter PFM mode.

$$I_{\text{PFM_enter}} = \frac{V_{\text{IN_DCDC}}}{32 \Omega} \quad (1)$$

Equation 2: Average output current threshold to leave PFM mode.

$$I_{\text{PFM_leave}} = \frac{V_{\text{IN_DCDC}}}{24 \Omega} \quad (2)$$

During the Power Save Mode the output voltage is monitored with a comparator. As the output voltage falls below the skip comparator threshold (skip comp) of $V_{\text{OUTnominal}} + 1\%$, the P-channel switch will turn on and the converter effectively delivers a constant current as defined above. If the load is below the delivered current then the output voltage will rise until the same threshold is crossed again, whereupon all switching activity ceases, hence reducing the quiescent current to a minimum until the output voltage has dropped below the threshold again. If the load current is greater than the delivered current then the output voltage will fall until it crosses the skip comparator low (Skip Comp Low) threshold set to 1% below nominal V_{out} , whereupon Power Save Mode is exited and the converter returns to PWM mode.

These control methods reduce the quiescent current typically to 12µA per converter and the switching frequency to a minimum thereby achieving the highest converter efficiency. The PFM mode operates with very low output voltage ripple. The ripple depends on the comparator delay and the size of the output capacitor; increasing capacitor values will make the output ripple tend to zero.

The Power Save Mode can be disabled by driving the MODE pin high. Both converters will operate in fixed PWM mode. Power Save Mode Enable/Disable applies to both converters.

Dynamic Voltage Positioning

This feature reduces the voltage under/overshoots at load steps from light to heavy load and vice versa. It is activated in Power Save Mode operation when the converter runs in PFM Mode. It provides more headroom for both the voltage drop at a load step increase and the voltage increase at a load throw-off. This improves load transient behavior.

At light loads, in which the converters operate in PFM Mode, the output voltage is regulated typically 1% higher than the nominal value. In case of a load transient from light load to heavy load, the output voltage will drop until it reaches the skip comparator low threshold set to -1% below the nominal value and enters PWM mode. During a load throw off from heavy load to light load, the voltage overshoot is also minimized due to active regulation turning on the N-channel switch.

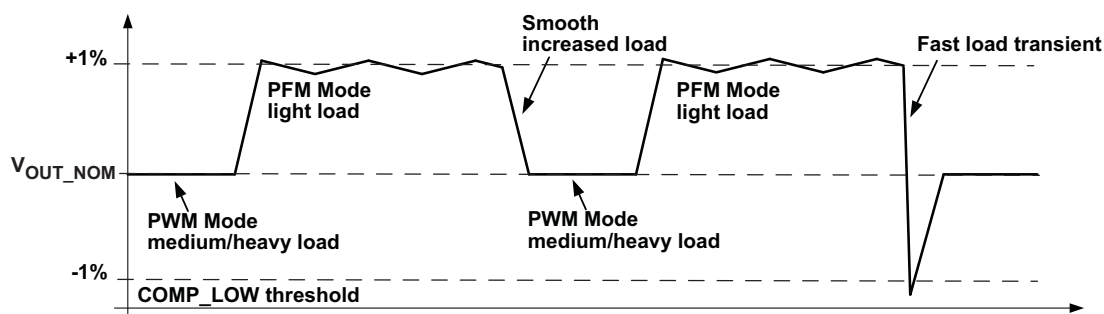

Figure 19. Dynamic Voltage Positioning

Soft Start

The two converters have an internal soft start circuit that limits the inrush current during start-up. During soft start, the output voltage ramp up is controlled as shown in Figure 20.

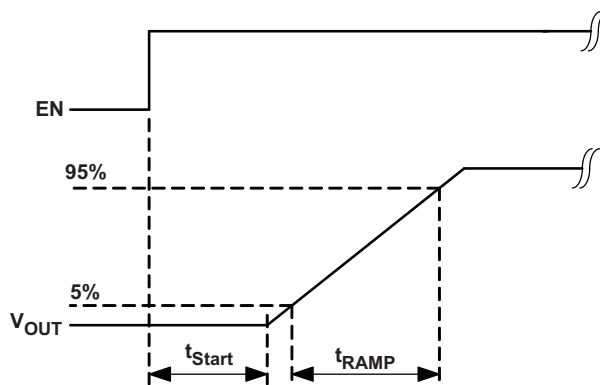

Figure 20. Soft Start

100% Duty Cycle Low Dropout Operation

The converters offer a low input to output voltage difference while still maintaining operation with the use of the 100% duty cycle mode. In this mode the P-channel switch is constantly turned on. This is particularly useful in battery-powered applications to achieve longest operation time by taking full advantage of the whole battery voltage range, i.e. The minimum input voltage to maintain regulation depends on the load current and output voltage and can be calculated as:

$$V_{in_{min}} = V_{out_{max}} + I_{out_{max}} \times (R_{DSon_{max}} + R_L) \quad (3)$$

with:

$I_{out_{max}}$ = maximum output current plus inductor ripple current

$R_{DSon_{max}}$ = maximum P-channel switch $r_{DS(on)}$

R_L = DC resistance of the inductor

$V_{out_{max}}$ = nominal output voltage plus maximum output voltage tolerance

With decreasing load current, the device automatically switches into pulse skipping operation in which the power stage operates intermittently based on load demand. By running cycles periodically the switching losses are minimized and the device runs with a minimum quiescent current maintaining high efficiency.

In power save mode the converter only operates when the output voltage trips below its nominal output voltage. It ramps up the output voltage with several pulses and goes again into power save mode once the output voltage exceeds the nominal output voltage.

Undervoltage Lockout

The undervoltage lockout circuit prevents the device from malfunctioning by disabling the converter at low input voltages and from excessive discharge of the battery. The undervoltage lockout threshold is typically 1.8 V, max 2 V.

MODE SELECTION

The MODE pin allows mode selection between forced PWM Mode and power Save Mode for both converters. Connecting this pin to GND enables the automatic PWM and power save mode operation. The converters operate in fixed frequency PWM mode at moderate to heavy loads and in the PFM mode during light loads, maintaining high efficiency over a wide load current range.

Pulling the MODE pin high forces both converters to operate constantly in the PWM mode even at light load currents. The advantage is the converters operate with a fixed frequency that allows simple filtering of the switching frequency for noise sensitive applications. In this mode, the efficiency is lower compared to the power save mode during light loads. For additional flexibility it is possible to switch from power save mode to forced PWM mode during operation. This allows efficient power management by adjusting the operation of the converter to the specific system requirements.

ENABLE

The devices have a separate enable pin for each of the dc/dc converters and for each of the LDO to start up independently. If EN_DCDC1, EN_DCDC2, EN_LDO1, EN_LDO2, EN_LDO3 are set to high, the corresponding converter starts up with soft start as previously described.

Pulling the enable pin low forces the device into shutdown, with a shutdown quiescent current as defined in the electrical characteristics. In this mode, the P and N-Channel MOSFETs are turned-off, and the entire internal control circuitry is switched-off. If disabled, the outputs of the LDOs are pulled low by internal 350Ω resistors, actively discharging the output capacitor. For proper operation the enable pins must be terminated and must not be left unconnected.

RESET

The TPS65053x contain circuitry that can generate a reset pulse for a processor with a 100ms delay time. The input voltage at a comparator is sensed at an input called THRESHOLD. When the voltage exceeds the 1V threshold, the output goes high after a 100ms delay time. This circuitry is functional as soon as the supply voltage at Vcc exceeds the undervoltage lockout threshold. The RESET circuitry is active even if all DCDC converters and LDOs are disabled.

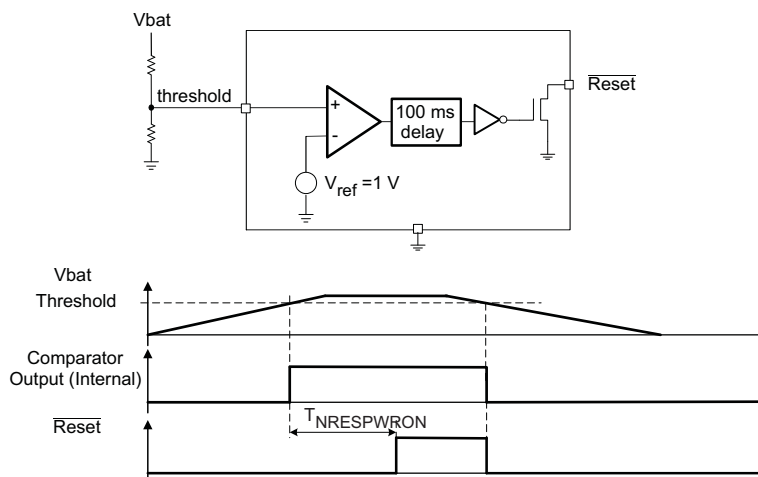

Figure 21. $\overline{\text{RESET}}$ Pulse Circuit

SHORT-CIRCUIT PROTECTION

All outputs are short circuit protected with a maximum output current as defined in the Electrical Characteristics.

THERMAL SHUTDOWN

As soon as the junction temperature, T_J , exceeds typically 150°C for the DCDC converters, the device goes into thermal shutdown. In this mode, the P and N-Channel MOSFETs are turned-off. The device continues its operation when the junction temperature falls below the thermal shutdown hysteresis again. A thermal shutdown for one of the DCDC converters will disable both converters simultaneously.

The thermal shutdown temperature for the LDOs are set to typically 140°C. Therefore a LDO which may be used to power an external voltage will never heat up the chip high enough to turn off the DCDC converters. If one LDO exceeds the thermal shutdown temperature, all LDOs will turn off simultaneously.

Low Dropout Voltage Regulators

The low dropout voltage regulators are designed to be stable with low value ceramic input and output capacitors. They operate with input voltages down to 1.5V. The LDOs offer a maximum dropout voltage of 280mV at rated output current. Each LDO supports a current limit feature. The LDOs are enabled by the EN_LDO1, EN_LDO2, and EN_LDO3 pin. The output voltage of LDO1 and LDO2 is set using an external resistor divider whereas LDO3 has a fixed output voltage of 1.30 V for TPS65053-Q1, 1.20V for TPS650531-Q1 and 1.50V for TPS650532-Q1.

APPLICATION INFORMATION

TYPICAL APPLICATION CIRCUIT

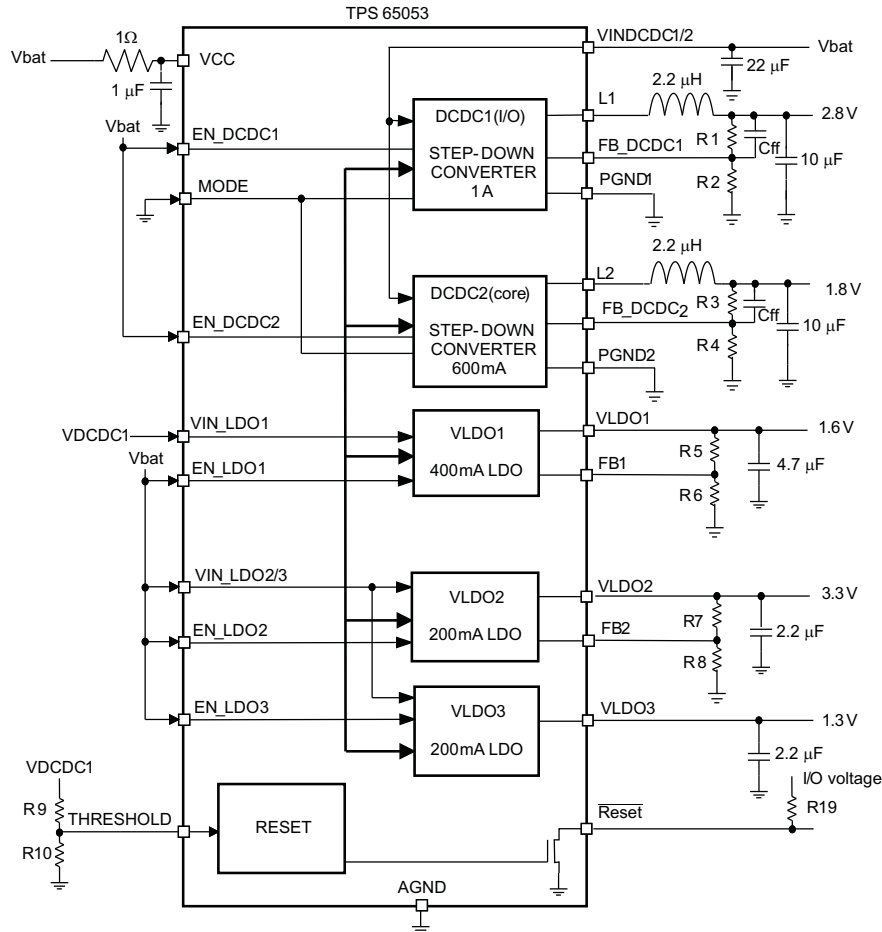

Output Voltage Setting

The output voltage of the DCDC converters can be set by an external resistor network and can be calculated to:

$$V_{OUT} = V_{REF} \times \left(1 + \frac{R1}{R2}\right) \quad (4)$$

with an internal reference voltage V_{ref} , 0.6 V (typical).

It is recommended to set the total resistance of $R1 + R2$ to less than 1MΩ. The resistor network connects to the input of the feedback amplifier; therefore, need some small feedforward capacitor in parallel to R1. A typical value of 47pF is sufficient.

$$R1 = R2 \times \left(\frac{V_{OUT}}{V_{FB_DCDC1}}\right) - R2 \quad (5)$$

Table 1. Typical Resistor Values

OUTPUT VOLTAGE	R1	R2	NOMINAL VOLTAGE	TYPICAL CFF
3.3 V	680 kΩ	150 kΩ	3.32 V	47 pF
3.0 V	510 kΩ	130 kΩ	2.95 V	47 pF
2.85 V	560 kΩ	150 kΩ	2.84 V	47 pF
2.5 V	510 kΩ	160 kΩ	2.51 V	47 pF
1.8 V	300 kΩ	150 kΩ	1.80 V	47 pF
1.6 V	200 kΩ	120 kΩ	1.60 V	47 pF
1.5 V	300 kΩ	200 kΩ	1.50 V	47 pF
1.2 V	330 kΩ	330 kΩ	1.20 V	47 pF

OUTPUT FILTER DESIGN (INDUCTOR AND OUTPUT CAPACITOR)

Inductor Selection

The two converters operate typically with 2.2μH output inductor. Larger or smaller inductor values can be used to optimize the performance of the device for specific operation conditions. For output voltages higher than 2.8V, an inductor value of 3.3μH minimum should be selected, otherwise the inductor current will ramp down too fast causing imprecise internal current measurement and therefore increased output voltage ripple under some operating conditions in PFM mode.

The selected inductor has to be rated for its DC resistance and saturation current. The DC resistance of the inductance will influence directly the efficiency of the converter. Therefore an inductor with lowest DC resistance should be selected for highest efficiency.

Equation 6 calculates the maximum inductor current under static load conditions. The saturation current of the inductor should be rated higher than the maximum inductor current as calculated with Equation 6. This is recommended because during heavy load transient the inductor current will rise above the calculated value.

$$\Delta I_L = V_{out} \times \frac{1 - \frac{V_{out}}{V_{in}}}{L \times f} \quad I_{Lmax} = I_{outmax} + \frac{\Delta I_L}{2} \tag{6}$$

with:

f = Switching Frequency (2.25-MHz typical)

L = Inductor Value

Δ I_L = Peak-to-peak inductor ripple current

I_{Lmax} = Maximum Inductor current

The highest inductor current occurs at maximum V_{in}. Open core inductors have a soft saturation characteristic, and they can normally handle higher inductor currents versus a comparable shielded inductor.

A more conservative approach is to select the inductor current rating just for the maximum switch current of the corresponding converter. It must be considered, that the core material from inductor to inductor differs and will have an impact on the efficiency especially at high switching frequencies. Refer to Table 2 and the typical applications for possible inductors.

Table 2. Tested Inductors

Inductor Type	Inductor Value	Supplier
LPS3010	2.2 μH	Coilcraft
LPS3015	3.3 μH	Coilcraft
LPS4012	2.2 μH	Coilcraft
VLF4012	2.2 μH	TDK

Output Capacitor Selection

The advanced Fast Response voltage mode control scheme of the two converters allow the use of small ceramic capacitors with a typical value of 10µF, without having large output voltage under and overshoots during heavy load transients. Ceramic capacitors having low ESR values result in lowest output voltage ripple and are therefore recommended. See the recommended components in [Table 4](#).

If ceramic output capacitors are used, the capacitor RMS ripple current rating will always meet the application requirements. Just for completeness, the RMS ripple current is calculated as:

$$I_{\text{RMSOut}} = V_{\text{out}} \times \frac{1 - \frac{V_{\text{out}}}{V_{\text{in}}}}{L \times f} \times \frac{1}{2 \times \sqrt{3}} \quad (7)$$

At nominal load current, the inductive converters operate in PWM mode and the overall output voltage ripple is the sum of the voltage spike caused by the output capacitor ESR plus the voltage ripple caused by charging and discharging the output capacitor:

$$\Delta V_{\text{out}} = V_{\text{out}} \times \frac{1 - \frac{V_{\text{out}}}{V_{\text{in}}}}{L \times f} \times \left(\frac{1}{8 \times C_{\text{out}} \times f} + \text{ESR} \right) \quad (8)$$

Where the highest output voltage ripple occurs at the highest input voltage V_{in} .

At light load currents, the converters operate in Power Save Mode and the output voltage ripple is dependent on the output capacitor value. The output voltage ripple is set by the internal comparator delay and the external capacitor. The typical output voltage ripple is less than 1% of the nominal output voltage.

Input Capacitor Selection

Because of the nature of the buck converter, having a pulsating input current, a low ESR input capacitor is required for best input voltage filtering and minimizing the interference with other circuits caused by high input voltage spikes. The converters need a ceramic input capacitor of 10 µF. The input capacitor can be increased without any limit for better input voltage filtering.

Table 3. Possible Capacitors For DCDC Converters And LDOs

Capacitor Value	Size	Supplier	Type
2.2 µF	0805	TDK C2012X5R0J226MT	Ceramic
2.2 µF	0805	Taiyo Yuden JMK212BJ226MG	Ceramic
10 µF	0805	Taiyo Yuden JMK212BJ106M	Ceramic
10 µF	0805	TDK C2012X5R0J106M	Ceramic

Low Drop Out Voltage Regulators (LDOs)

The output voltage of LDO1 and LDO2 can be set by an external resistor network and can be calculated to:

$$V_{\text{OUT}} = V_{\text{REF}} \times \left(1 + \frac{R5}{R6} \right) \quad (9)$$

with an internal reference voltage, V_{REF} , typical 1 V.

It is recommended to set the total resistance of $R5 + R6$ to less than 1MΩ. Typically, there is no feedforward capacitor needed at the voltage dividers for the LDOs.

$$V_{\text{OUT}} = V_{\text{FB_LDOx}} \times \frac{R5 + R6}{R6} \quad R5 = R6 \times \left(\frac{V_{\text{OUT}}}{V_{\text{FB_LDOx}}} \right) - R6 \quad (10)$$

Table 4. Typical Resistor Values

OUTPUT VOLTAGE	R5	R6	NOMINAL VOLTAGE
3.3 V	300 kΩ	130 kΩ	3.31 V
3 V	300 kΩ	150 kΩ	3.00 V
2.85 V	240 kΩ	130 kΩ	2.85 V
2.80 V	360 kΩ	200 kΩ	2.80 V
2.5 V	300 kΩ	200 kΩ	2.50 V
1.8 V	240 kΩ	300 kΩ	1.80 V
1.5 V	150 kΩ	300 kΩ	1.50 V
1.3 V	36 kΩ	120 kΩ	1.30 V
1.2 V	100 kΩ	510 kΩ	1.19 V
1.1 V	33 kΩ	330 kΩ	1.1 V

Input Capacitor and Output Capacitor Selection for the LDOs

The minimum input capacitor on VIN_LDO1 and on VIN_LDO2/3 is 2.2 μF minimum. LDO1 is designed to be stable with an output capacitor of 4.7 μF minimum; whereas, LDO2 and LDO3 are stable with a minimum capacitor value of 2.2 μF.



PACKAGING INFORMATION

Orderable Device	Status (1)	Package Type	Package Drawing	Pins	Package Qty	Eco Plan (2)	Lead/Ball Finish	MSL Peak Temp (3)	Op Temp (°C)	Top-Side Markings (4)	Samples
TPS65053IRGERQ1	ACTIVE	VQFN	RGE	24	3000	Green (RoHS & no Sb/Br)	CU NIPDAU	Level-3-260C-168 HR	-40 to 85	TPS 65053Q	

(1) The marketing status values are defined as follows:

ACTIVE: Product device recommended for new designs.

LIFEBUY: TI has announced that the device will be discontinued, and a lifetime-buy period is in effect.

NRND: Not recommended for new designs. Device is in production to support existing customers, but TI does not recommend using this part in a new design.

PREVIEW: Device has been announced but is not in production. Samples may or may not be available.

OBSOLETE: TI has discontinued the production of the device.

(2) Eco Plan - The planned eco-friendly classification: Pb-Free (RoHS), Pb-Free (RoHS Exempt), or Green (RoHS & no Sb/Br) - please check <http://www.ti.com/productcontent> for the latest availability information and additional product content details.

TBD: The Pb-Free/Green conversion plan has not been defined.

Pb-Free (RoHS): TI's terms "Lead-Free" or "Pb-Free" mean semiconductor products that are compatible with the current RoHS requirements for all 6 substances, including the requirement that lead not exceed 0.1% by weight in homogeneous materials. Where designed to be soldered at high temperatures, TI Pb-Free products are suitable for use in specified lead-free processes.

Pb-Free (RoHS Exempt): This component has a RoHS exemption for either 1) lead-based flip-chip solder bumps used between the die and package, or 2) lead-based die adhesive used between the die and leadframe. The component is otherwise considered Pb-Free (RoHS compatible) as defined above.

Green (RoHS & no Sb/Br): TI defines "Green" to mean Pb-Free (RoHS compatible), and free of Bromine (Br) and Antimony (Sb) based flame retardants (Br or Sb do not exceed 0.1% by weight in homogeneous material)

(3) MSL, Peak Temp. -- The Moisture Sensitivity Level rating according to the JEDEC industry standard classifications, and peak solder temperature.

(4) Multiple Top-Side Markings will be inside parentheses. Only one Top-Side Marking contained in parentheses and separated by a "-" will appear on a device. If a line is indented then it is a continuation of the previous line and the two combined represent the entire Top-Side Marking for that device.

Important Information and Disclaimer: The information provided on this page represents TI's knowledge and belief as of the date that it is provided. TI bases its knowledge and belief on information provided by third parties, and makes no representation or warranty as to the accuracy of such information. Efforts are underway to better integrate information from third parties. TI has taken and continues to take reasonable steps to provide representative and accurate information but may not have conducted destructive testing or chemical analysis on incoming materials and chemicals. TI and TI suppliers consider certain information to be proprietary, and thus CAS numbers and other limited information may not be available for release.

In no event shall TI's liability arising out of such information exceed the total purchase price of the TI part(s) at issue in this document sold by TI to Customer on an annual basis.

OTHER QUALIFIED VERSIONS OF TPS65053-Q1 :

- Catalog: [TPS65053](#)



Distributor of Texas Instruments: Excellent Integrated System Limited

Datasheet of TPS65053IRGERQ1 - IC PWR MGT 5CH W/3 LDO 24VQFN

Contact us: sales@integrated-circuit.com Website: www.integrated-circuit.com

PACKAGE OPTION ADDENDUM



www.ti.com

11-Apr-2013

NOTE: Qualified Version Definitions:

- Catalog - TI's standard catalog product

TAPE AND REEL INFORMATION

REEL DIMENSIONS

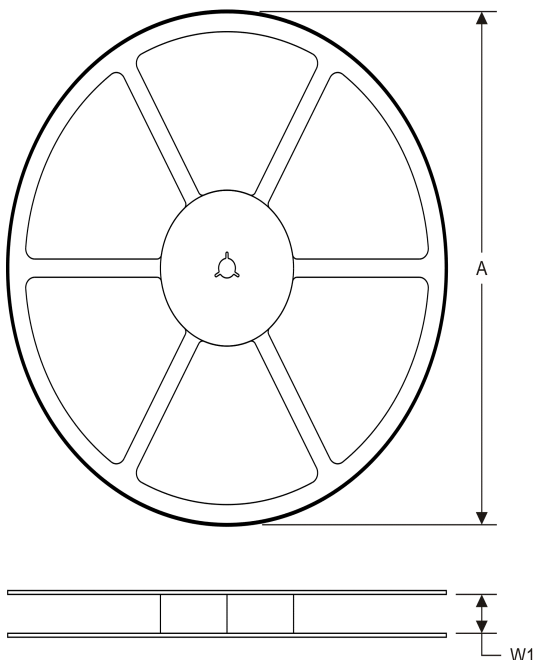

TAPE DIMENSIONS

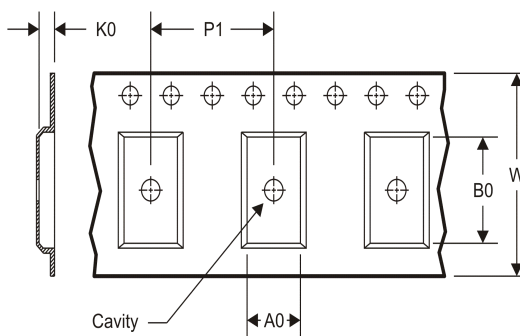

A0	Dimension designed to accommodate the component width
B0	Dimension designed to accommodate the component length
K0	Dimension designed to accommodate the component thickness
W	Overall width of the carrier tape
P1	Pitch between successive cavity centers

TAPE AND REEL INFORMATION

*All dimensions are nominal

Device	Package Type	Package Drawing	Pins	SPQ	Reel Diameter (mm)	Reel Width W1 (mm)	A0 (mm)	B0 (mm)	K0 (mm)	P1 (mm)	W (mm)	Pin1 Quadrant
TPS65053IRGERQ1	VQFN	RGE	24	3000	330.0	12.4	4.25	4.25	1.15	8.0	12.0	Q2

TAPE AND REEL BOX DIMENSIONS

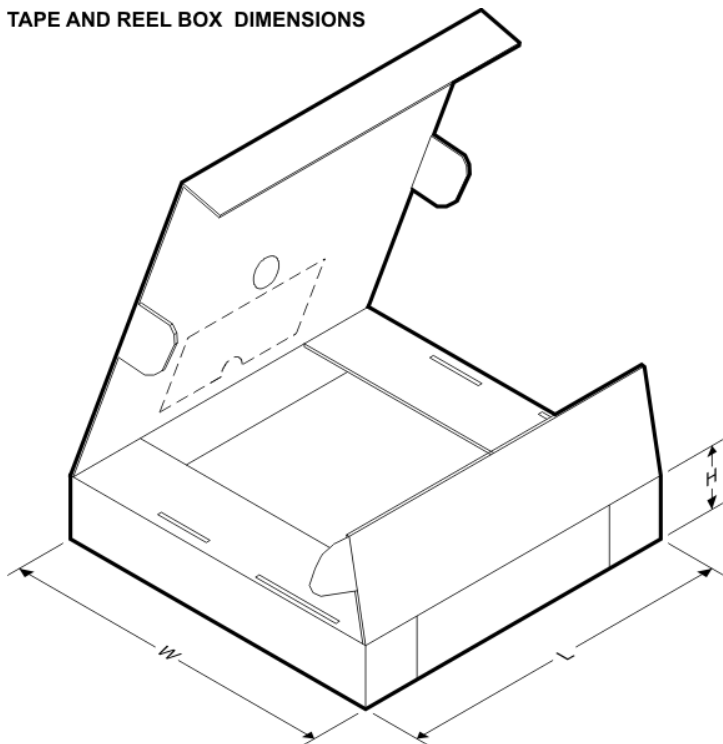

*All dimensions are nominal

Device	Package Type	Package Drawing	Pins	SPQ	Length (mm)	Width (mm)	Height (mm)
TPS65053IRGERQ1	VQFN	RGE	24	3000	367.0	367.0	35.0

MECHANICAL DATA

RGE (S-PVQFN-N24)

PLASTIC QUAD FLATPACK NO-LEAD

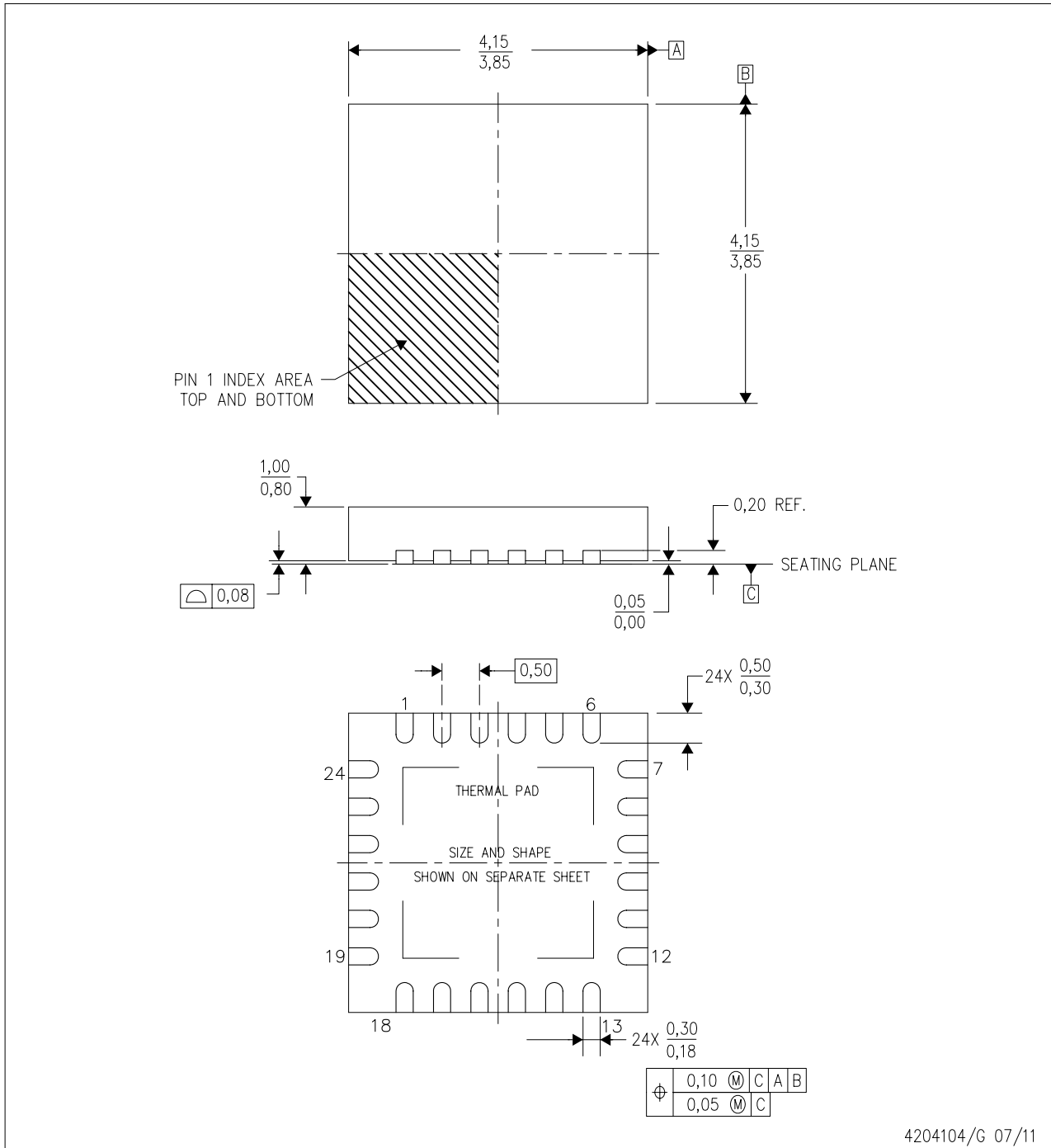

4204104/G 07/11

- NOTES:
- A. All linear dimensions are in millimeters. Dimensioning and tolerancing per ASME Y14.5M-1994.
 - B. This drawing is subject to change without notice.
 - C. Quad Flatpack, No-Leads (QFN) package configuration.
 - D. The package thermal pad must be soldered to the board for thermal and mechanical performance.
 - E. See the additional figure in the Product Data Sheet for details regarding the exposed thermal pad features and dimensions.
 - F. Falls within JEDEC MO-220.

THERMAL PAD MECHANICAL DATA

RGE (S-PVQFN-N24)

PLASTIC QUAD FLATPACK NO-LEAD

THERMAL INFORMATION

This package incorporates an exposed thermal pad that is designed to be attached directly to an external heatsink. The thermal pad must be soldered directly to the printed circuit board (PCB). After soldering, the PCB can be used as a heatsink. In addition, through the use of thermal vias, the thermal pad can be attached directly to the appropriate copper plane shown in the electrical schematic for the device, or alternatively, can be attached to a special heatsink structure designed into the PCB. This design optimizes the heat transfer from the integrated circuit (IC).

For information on the Quad Flatpack No-Lead (QFN) package and its advantages, refer to Application Report, QFN/SON PCB Attachment, Texas Instruments Literature No. SLUA271. This document is available at www.ti.com.

The exposed thermal pad dimensions for this package are shown in the following illustration.

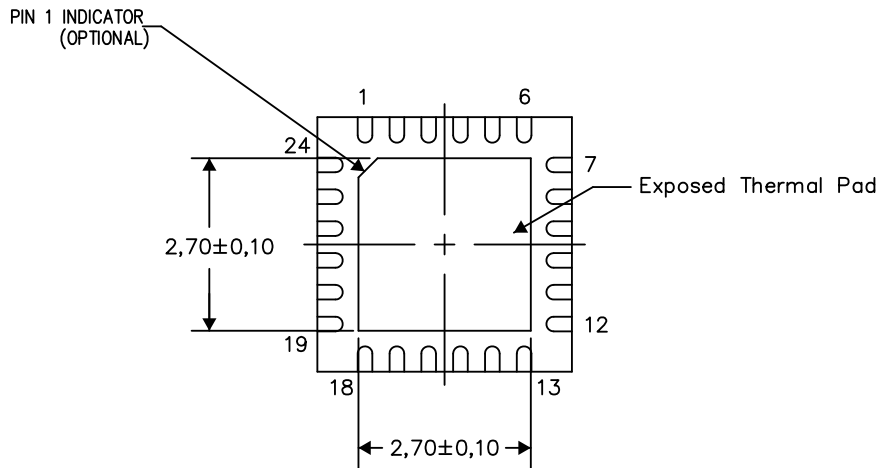

Bottom View

Exposed Thermal Pad Dimensions

4206344-5/AK 08/15

NOTES: A. All linear dimensions are in millimeters

LAND PATTERN DATA

RGE (S-PVQFN-N24)

PLASTIC QUAD FLATPACK NO-LEAD

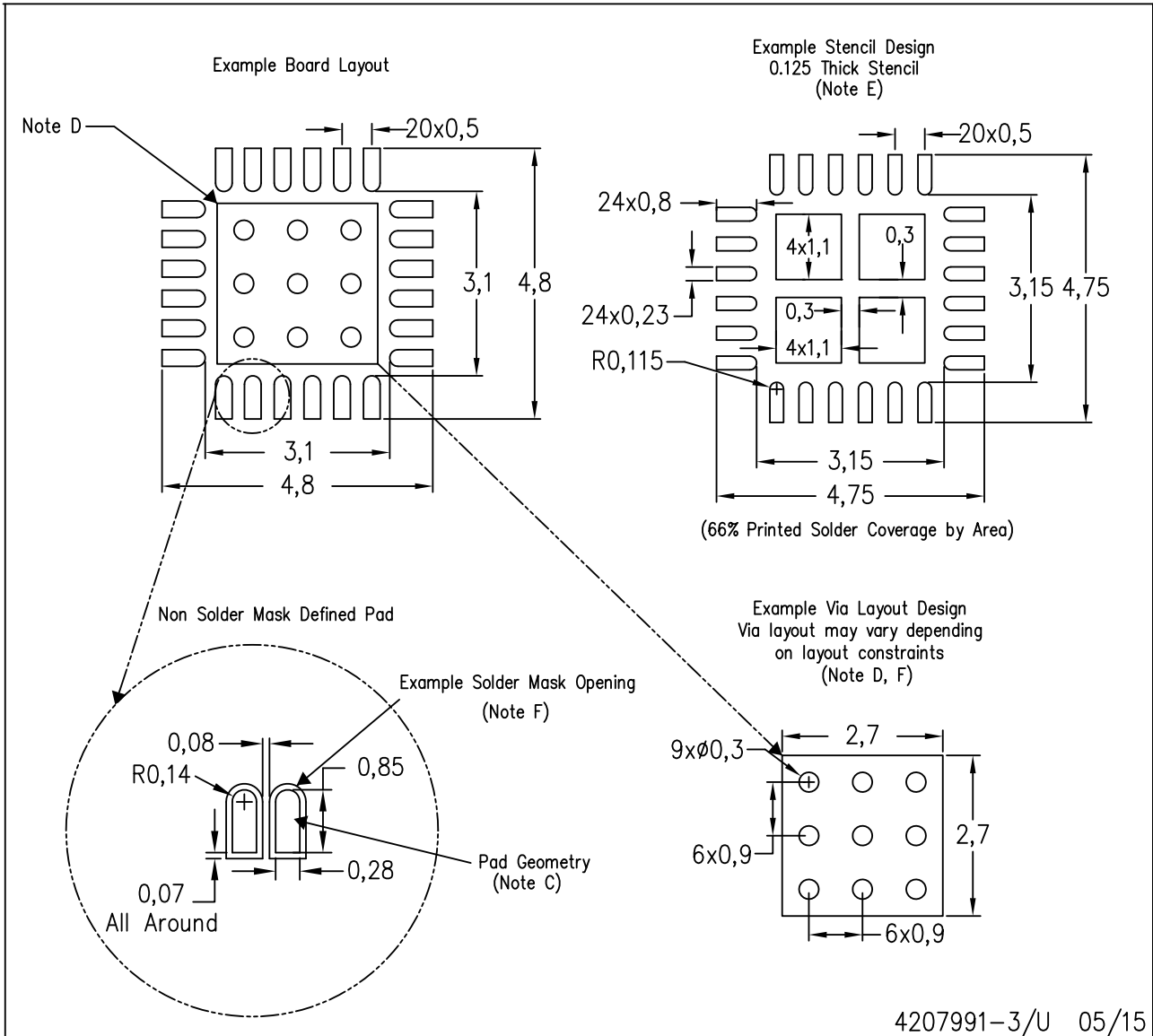

- NOTES:
- All linear dimensions are in millimeters.
 - This drawing is subject to change without notice.
 - Publication IPC-7351 is recommended for alternate designs.
 - This package is designed to be soldered to a thermal pad on the board. Refer to Application Note, Quad Flat-Pack Packages, Texas Instruments Literature No. SLUA271, and also the Product Data Sheets for specific thermal information, via requirements, and recommended board layout. These documents are available at www.ti.com <<http://www.ti.com>>.
 - Laser cutting apertures with trapezoidal walls and also rounding corners will offer better paste release. Customers should contact their board assembly site for stencil design recommendations. Refer to IPC 7525 for stencil design considerations.
 - Customers should contact their board fabrication site for recommended solder mask tolerances and via tenting recommendations for vias placed in the thermal pad.

IMPORTANT NOTICE

Texas Instruments Incorporated and its subsidiaries (TI) reserve the right to make corrections, enhancements, improvements and other changes to its semiconductor products and services per JESD46, latest issue, and to discontinue any product or service per JESD48, latest issue. Buyers should obtain the latest relevant information before placing orders and should verify that such information is current and complete. All semiconductor products (also referred to herein as “components”) are sold subject to TI’s terms and conditions of sale supplied at the time of order acknowledgment.

TI warrants performance of its components to the specifications applicable at the time of sale, in accordance with the warranty in TI’s terms and conditions of sale of semiconductor products. Testing and other quality control techniques are used to the extent TI deems necessary to support this warranty. Except where mandated by applicable law, testing of all parameters of each component is not necessarily performed.

TI assumes no liability for applications assistance or the design of Buyers’ products. Buyers are responsible for their products and applications using TI components. To minimize the risks associated with Buyers’ products and applications, Buyers should provide adequate design and operating safeguards.

TI does not warrant or represent that any license, either express or implied, is granted under any patent right, copyright, mask work right, or other intellectual property right relating to any combination, machine, or process in which TI components or services are used. Information published by TI regarding third-party products or services does not constitute a license to use such products or services or a warranty or endorsement thereof. Use of such information may require a license from a third party under the patents or other intellectual property of the third party, or a license from TI under the patents or other intellectual property of TI.

Reproduction of significant portions of TI information in TI data books or data sheets is permissible only if reproduction is without alteration and is accompanied by all associated warranties, conditions, limitations, and notices. TI is not responsible or liable for such altered documentation. Information of third parties may be subject to additional restrictions.

Resale of TI components or services with statements different from or beyond the parameters stated by TI for that component or service voids all express and any implied warranties for the associated TI component or service and is an unfair and deceptive business practice. TI is not responsible or liable for any such statements.

Buyer acknowledges and agrees that it is solely responsible for compliance with all legal, regulatory and safety-related requirements concerning its products, and any use of TI components in its applications, notwithstanding any applications-related information or support that may be provided by TI. Buyer represents and agrees that it has all the necessary expertise to create and implement safeguards which anticipate dangerous consequences of failures, monitor failures and their consequences, lessen the likelihood of failures that might cause harm and take appropriate remedial actions. Buyer will fully indemnify TI and its representatives against any damages arising out of the use of any TI components in safety-critical applications.

In some cases, TI components may be promoted specifically to facilitate safety-related applications. With such components, TI’s goal is to help enable customers to design and create their own end-product solutions that meet applicable functional safety standards and requirements. Nonetheless, such components are subject to these terms.

No TI components are authorized for use in FDA Class III (or similar life-critical medical equipment) unless authorized officers of the parties have executed a special agreement specifically governing such use.

Only those TI components which TI has specifically designated as military grade or “enhanced plastic” are designed and intended for use in military/aerospace applications or environments. Buyer acknowledges and agrees that any military or aerospace use of TI components which have **not** been so designated is solely at the Buyer’s risk, and that Buyer is solely responsible for compliance with all legal and regulatory requirements in connection with such use.

TI has specifically designated certain components as meeting ISO/TS16949 requirements, mainly for automotive use. In any case of use of non-designated products, TI will not be responsible for any failure to meet ISO/TS16949.

Products

Audio	www.ti.com/audio
Amplifiers	amplifier.ti.com
Data Converters	dataconverter.ti.com
DLP® Products	www.dlp.com
DSP	dsp.ti.com
Clocks and Timers	www.ti.com/clocks
Interface	interface.ti.com
Logic	logic.ti.com
Power Mgmt	power.ti.com
Microcontrollers	microcontroller.ti.com
RFID	www.ti-rfid.com
OMAP Applications Processors	www.ti.com/omap
Wireless Connectivity	www.ti.com/wirelessconnectivity

Applications

Automotive and Transportation	www.ti.com/automotive
Communications and Telecom	www.ti.com/communications
Computers and Peripherals	www.ti.com/computers
Consumer Electronics	www.ti.com/consumer-apps
Energy and Lighting	www.ti.com/energy
Industrial	www.ti.com/industrial
Medical	www.ti.com/medical
Security	www.ti.com/security
Space, Avionics and Defense	www.ti.com/space-avionics-defense
Video and Imaging	www.ti.com/video

TI E2E Community

e2e.ti.com