

Excellent Integrated System Limited

Stocking Distributor

Click to view price, real time Inventory, Delivery & Lifecycle Information:

[Molex Connector Corporation](#)
[0760556608](#)

For any questions, you can email us directly:
sales@integrated-circuit.com

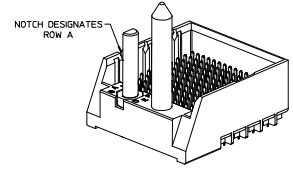
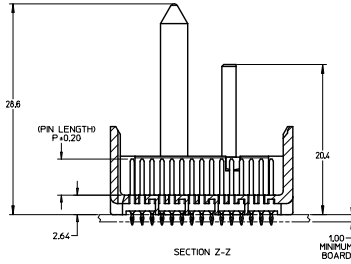
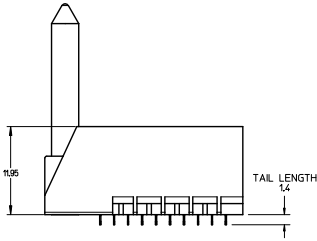
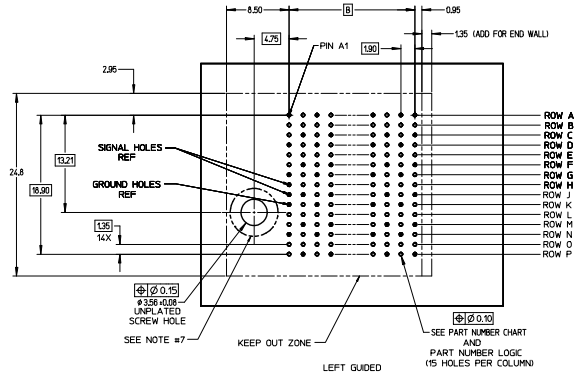
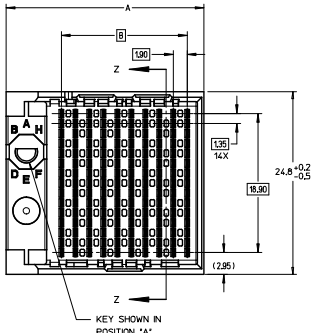

- NOTES:**
1. MATERIALS: HOUSING - LIQUID CRYSTAL POLYMER (LCP) GLASS-FILLED, UL94V-0
 2. TERMINALS - HIGH PERFORMANCE COPPER ALLOY
FINISH 5 MICRONCH MINIMUM GOLD FLASH OVER 20 MICRONCH MINIMUM
Pd-Ni IN CONTACT AREA, SELECTIVE TIN ON PCB TAILS, NICKEL OVERALL.
 3. REFER TO MOLEX PRODUCT SPECIFICATION PS-76060-999 FOR PERFORMANCE SPECIFICATIONS AND ADDITIONAL PCB INFORMATION.
 4. THIS PART CONFORMS TO CLASS B REQUIREMENTS OF MOLEX COSMETIC SPEC PS-45499-002.
 5. PACKAGE PER: PK-70873-759.
 6. SEE SHEETS 2 & 3 FOR PART NUMBERS AND BOARD RELATIONSHIPS.
 7. FOR GROUNDED GUIDE PINS USE DIA. 3.56 +/-0.08 (PTH) DIA. 3.66 (DRILL) AND DIA 6.5 (PAD).
 8. MATES WITH IMPACT DC SERIES NO. 76060.
 9. KEEP OUT ZONE FOR BP HOUSING LENGTH INCLUDES AN ADDITIONAL 10MM TO ACCOMMODATE FOR SPACE REQUIRED BY DC FRONT HOUSING.
 10. REFER TO MOLEX PCB ROUTING GUIDE AS-76060-990 FOR ANTPAD AND ROUTING RECOMMENDATIONS.
 11. CONNECTORS SUPPLIED WITH A 2-56 UNC-2A SCREW.
 12. THESE DIMENSIONS REPRESENT THE AREA NEEDED TO ACCOMMODATE CONNECTOR INSERTION AND REPAIR ON THE PCB BOARD, THIS IS REFERRED TO AS THE 'CONNECTOR KEEP OUT ZONE' AND DOES NOT REPRESENT THE ACTUAL PERIMETER OF THE CONNECTOR, WHEN LAYING OUT A PCB BOARD FOR CONNECTORS STACK TOGETHER, USE A 1.9mm PROGRESSION.

Pd-Ni
PLATING

INITIAL RELEASE EC NO. UEP27016-2332 DRAWN: SVANG01 CHECKED: CHOKOMALLE APPROVED: SMILLER DATE: 2015/12/09 DATE: 2015/12/09 DATE: 2015/12/17	QUALITY SYMBOLS 4 PLACES ±0 3 PLACES ±0 2 PLACES ±0.13 1 PLACE ±0.25 0 PLACE ±	GENERAL TOLERANCES (UNLESS SPECIFIED) mm INCH		DIMENSION STYLE MM ONLY		SCALE 4:1	DESIGN UNITS METRIC	THIRD ANGLE PROJECTION
		DRAWN BY SVANG01 DATE 2015/12/09		CHECKED BY MWOLFE DATE 2015/12/09		APPROVED BY SMILLER DATE 2015/12/17		MATERIAL NO. SEE TABLE
DRAFT WHERE APPLICABLE MUST REMAIN WITHIN DIMENSIONS				SEE TABLE		DOCUMENT NO. RSD-173430-002		SHEET NO. 1 OF 3

PART NUMBER LOGIC

173430-****

MODULE TYPE

- 3 = GUIDE LEFT, TIN
- 7 = GUIDE LEFT END WALL, TIN

PIN LENGTH (P)

- 3 = 4.50 (SHORT COMPLIANT, 0.46±0.05 PTH)
- 4 = 4.90 (SHORT COMPLIANT, 0.46±0.05 PTH)
- 5 = 5.50 (SHORT COMPLIANT, 0.46±0.05 PTH)
- 6 = 4.50 (MICRO COMPLIANT, 0.39±0.05 PTH)
- 7 = 4.90 (MICRO COMPLIANT, 0.39±0.05 PTH)
- 8 = 5.50 (MICRO COMPLIANT, 0.39±0.05 PTH)

OF COLUMNS

- 1 = 10 COL
- 2 = 12 COL
- 6 = 16 COL
- 7 = 14 COL

KEY ORIENTATION

- 0 = NO KEY
- 1 = A
- 2 = B
- 3 = C
- 4 = D
- 5 = E
- 6 = F
- 7 = G
- 8 = H

PART NUMBER TABLE

MATERIAL NUMBER	# OF COLUMNS	# OF DIFF PAIR	DIM 'A'	DIM 'B'	
173430-#1**	10	50	26.9	17.10	GUIDE LEFT END WALL OPTION
173430-#2**	12	60	30.7	20.90	
173430-#7**	14	70	34.5	24.70	
173430-#6**	16	80	38.3	28.50	

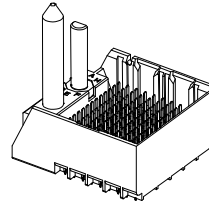

GUIDE LEFT
END WALL
OPTION

MATERIAL NUMBER	# OF COLUMNS	# OF DIFF PAIR	DIM 'A'	DIM 'B'	
173430-#1**	10	50	25.5	17.10	GUIDE LEFT OPEN WALL OPTION
173430-#2**	12	60	29.3	20.90	
173430-#7**	14	70	33.1	24.70	
173430-#6**	16	80	36.9	28.50	

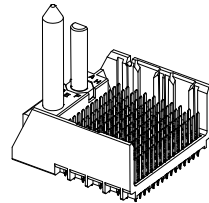

GUIDE LEFT
OPEN WALL
OPTION

SEE SHEET 1 EC NO: UCP2016-2332 DRW: SVANG01 2015/12/09 CHK: MWOLFE 2015/12/09 APPR: SMILLER 2015/12/17	QUALITY SYMBOLS ∇=0 ∇=0.13 ∇=0.25	GENERAL TOLERANCES (UNLESS SPECIFIED)		DIMENSION STYLE		SCALE	DESIGN UNITS	THIRD ANGLE PROJECTION	
				MM ONLY		2:1	METRIC		
		4 PLACES ± --- ± ---		DRAWN BY DATE		TITLE IMPACT 5 PAIR HEADER LEFT GUIDED PDNI ASSEMBLY SALES DRAWING 			
		3 PLACES ± --- ± ---		SVANG01 2015/12/09					
2 PLACES ± 0.13 ± ---		CHECKED BY DATE							
1 PLACE ± 0.25 ± ---		MWOLFE 2015/12/09							
0 PLACE ± ±		APPROVED BY DATE		MATERIAL NO.		DOCUMENT NO.	SHEET NO.		
ANGULAR ± 1/2°		SMILLER 2015/12/17		SEE TABLE		RSD-173430-002	2 OF 3		
DRAFT WHERE APPLICABLE MUST REMAIN WITHIN DIMENSIONS		THIS DRAWING CONTAINS INFORMATION THAT IS PROPRIETARY TO MOLEX INCORPORATED AND SHOULD NOT BE USED WITHOUT WRITTEN PERMISSION							

IMPACT 5 PAIR
BOARD RELATIONSHIPS

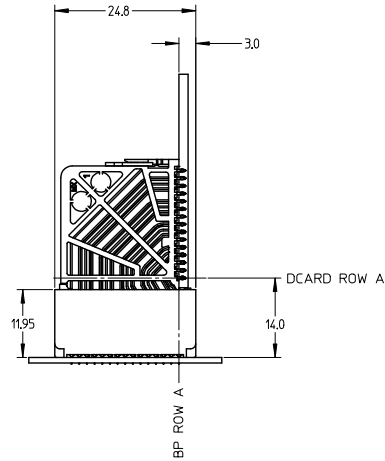
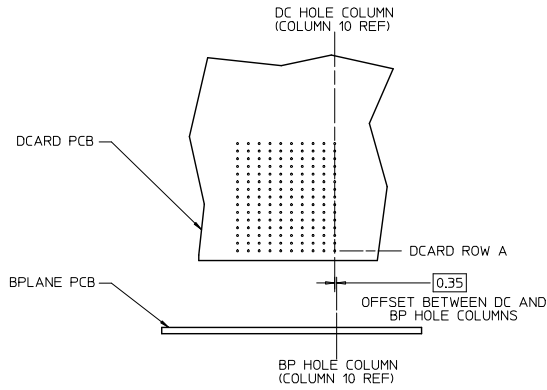
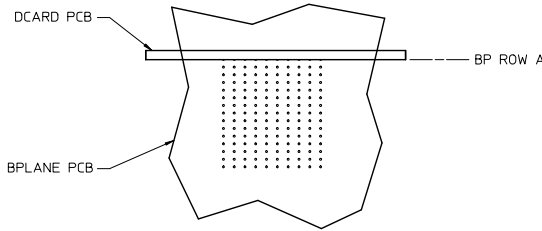

SEE SHEET 1 EC NO: UCP2016-2332 DRWNSVANG01 2015/12/09 CHKRMOLFE 2015/12/09 APPR:SMILLER 2015/12/17 A REV	QUALITY SYMBOLS	GENERAL TOLERANCES (UNLESS SPECIFIED)	DIMENSION STYLE	SCALE	DESIGN UNITS	THIRD ANGLE PROJECTION
	∇=0 ∇=0 ∇=0	4 PLACES ± --- ± --- 3 PLACES ± --- ± --- 2 PLACES ± 0.13 ± --- 1 PLACE ± 0.25 ± --- 0 PLACE ± ±	MM ONLY	2:1	METRIC	TITLE IMPACT 5 PAIR HEADER LEFT GUIDED PDNI ASSEMBLY SALES DRAWING molex MATERIAL NO. SEE TABLE DOCUMENT NO. RSD-173430-002 SHEET NO. 3 OF 3
		ANGULAR ± 1/2°				
		DRAFT WHERE APPLICABLE MUST REMAIN WITHIN DIMENSIONS				

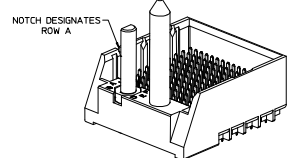
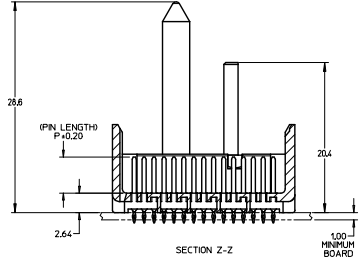
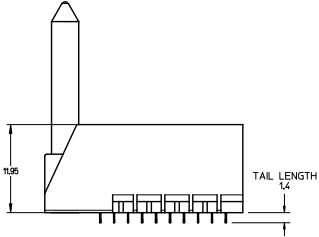
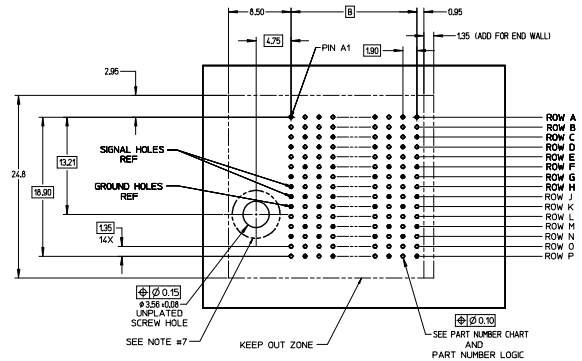
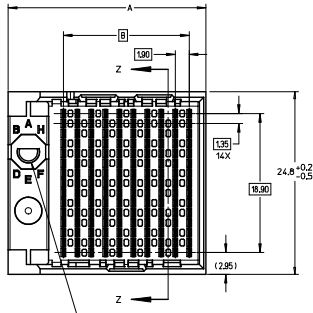

- NOTES:
1. MATERIALS: HOUSING - LIQUID CRYSTAL POLYMER (LCP) GLASS-FILLED, UL94V-0
TERMINALS - HIGH PERFORMANCE COPPER ALLOY
 2. FINISH: 30μ MIN GOLD IN CONTACT AREA, SELECTIVE TIN ON PCB TAILS, NICKEL OVERALL.
 3. REFER TO MOLEX PRODUCT SPECIFICATION PS-76060-999 FOR PERFORMANCE SPECIFICATIONS AND ADDITIONAL PCB INFORMATION.
 4. THIS PART CONFORMS TO CLASS B REQUIREMENTS OF MOLEX COSMETIC SPEC PS-45499-002.
 5. PACKAGE PER: PK-70873-759.
 6. SEE SHEETS 2 & 3 FOR PART NUMBERS AND BOARD RELATIONSHIPS.
 7. FOR GROUNDED GUIDE PINS USE DIA. 3.56 +/-0.08 (PTH) DIA. 3.66 (DRILL) AND DIA. 6.5 (PAD).
 8. MATES WITH IMPACT DC SERIES NO. 76060.
 9. KEEP OUT ZONE FOR BP HOUSING LENGTH INCLUDES AN ADDITIONAL 10MM TO ACCOMMODATE FOR SPACE REQUIRED BY DC FRONT HOUSING.
 10. REFER TO MOLEX PCB ROUTING GUIDE AS-76060-990 FOR ANTI-PAD AND ROUTING RECOMMENDATIONS.
 11. CONNECTORS SUPPLIED WITH A 2-56 UNC-2A SCREW.
 12. THESE DIMENSIONS REPRESENT THE AREA NEEDED TO ACCOMMODATE CONNECTOR INSERTION AND REPAIR ON THE PCB BOARD. THIS IS REFERRED TO AS THE "CONNECTOR KEEP OUT ZONE" AND DOES NOT REPRESENT THE ACTUAL PERIMETER OF THE CONNECTOR. WHEN LAYING OUT A PCB BOARD FOR CONNECTORS STACK TOGETHER, USE A 1.9mm PROGRESSION.

CONVERT TO LEAD-FREE EC NO. LFP2013-2018 DRAWN BY: BARBA 2017/11/26 CHECKED BY: INGHAM 2017/12/18 APPROVED BY: SHILLER 2017/12/21 DATE:	QUALITY SYMBOLS 4 PLACES ±0 3 PLACES ±0 2 PLACES ±0.13 1 PLACE ±0.25 0 PLACE ±	GENERAL TOLERANCES (UNLESS SPECIFIED) mm INCH ±0.13 ±0.005 ±0.25 ±0.010 ±0.50 ±0.020 ±1.00 ±0.040 ±1.50 ±0.060 ±2.00 ±0.080 ±3.00 ±0.120 ±4.00 ±0.160 ±5.00 ±0.200 ±6.00 ±0.240 ±8.00 ±0.320 ±10.00 ±0.400 ±15.00 ±0.600 ±20.00 ±0.800 ±30.00 ±1.200 ±40.00 ±1.600 ±50.00 ±2.000 ±60.00 ±2.400 ±80.00 ±3.200 ±100.00 ±4.000	DIMENSION STYLE MM ONLY DRAWN BY: MSANDBERG CHECKED BY: JLAURX APPROVED BY: JLAURX DATE: 05/24/2007 DATE: 05/24/2007 DATE: 2010/10/15	SCALE 4:1 DESIGN UNITS METRIC THIRD ANGLE PROJECTION	TITLE IMPACT 5 PAIR HEADER LEFT GUIDED ASSEMBLY SALES DRAWING molex DOCUMENT NO. SD-76055-002 SHEET NO. 1 OF 3
	DRAFT WHERE APPLICABLE MUST REMAIN WITHIN DIMENSIONS ANGULAR ±1/2° SEE TABLE THIS DRAWING CONTAINS INFORMATION THAT IS PROPRIETARY TO MOLEX INCORPORATED AND SHOULD NOT BE USED WITHOUT WRITTEN PERMISSION				

PART NUMBER LOGIC

76055-****

MODULE TYPE

- 3 = GUIDE LEFT, TIN
- 7 = GUIDE LEFT END WALL, TIN

PIN LENGTH (P)

- 3 = 4.50 (SHORT COMPLIANT, 0.46±0.05 PTH)
- 4 = 4.90 (SHORT COMPLIANT, 0.46±0.05 PTH)
- 5 = 5.50 (SHORT COMPLIANT, 0.46±0.05 PTH)
- 6 = 4.50 (MICRO COMPLIANT, 0.39±0.05 PTH)
- 7 = 4.90 (MICRO COMPLIANT, 0.39±0.05 PTH)
- 8 = 5.50 (MICRO COMPLIANT, 0.39±0.05 PTH)

OF COLUMNS

- 1 = 10 COL
- 2 = 12 COL
- 6 = 16 COL
- 7 = 14 COL

KEY ORIENTATION

- 0 = NO KEY
- 1 = A
- 2 = B
- 3 = C
- 4 = D
- 5 = E
- 6 = F
- 7 = G
- 8 = H

PART NUMBER TABLE

MATERIAL NUMBER	# OF COLUMNS	# OF DIFF PAIR	DIM 'A'	DIM 'B'	
76055- <i>x1**</i>	10	50	26.9	17.10	GUIDE LEFT END WALL OPTION
76055- <i>x2**</i>	12	60	30.7	20.90	
76055- <i>x7**</i>	14	70	34.5	24.70	
76055- <i>x6**</i>	16	80	38.3	28.50	

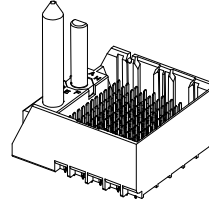

GUIDE LEFT
END WALL
OPTION

MATERIAL NUMBER	# OF COLUMNS	# OF DIFF PAIR	DIM 'A'	DIM 'B'	
76055- <i>x1**</i>	10	50	25.5	17.10	GUIDE LEFT OPEN WALL OPTION
76055- <i>x2**</i>	12	60	29.3	20.90	
76055- <i>x7**</i>	14	70	33.1	24.70	
76055- <i>x6**</i>	16	80	36.9	28.50	

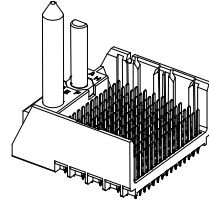

GUIDE LEFT
OPEN WALL
OPTION

SEE SHEET 1 EC NO: UCP2015-2078 DRAWN: IBARRA 2012/11/26 CHKD: BINGHAM 2012/12/18 APPR: SMILLER 2012/12/21	QUALITY SYMBOLS ∇=0 ∇=0 ∇=0	DESCRIPTION	GENERAL TOLERANCES (UNLESS SPECIFIED)		DIMENSION STYLE MM ONLY		SCALE 2:1	DESIGN UNITS METRIC	THIRD ANGLE PROJECTION		
					DRAWN BY MSANDBERG		DATE 05/24/2007		TITLE IMPACT 5 PAIR HEADER LEFT GUIDED ASSEMBLY SALES DRAWING 		
					CHECKED BY JLAURX		DATE 05/24/2007				
					APPROVED BY JLAURX		DATE 2010/10/15				
		MATERIAL NO.		DOCUMENT NO.		SHEET NO.					
DRAFT WHERE APPLICABLE MUST REMAIN WITHIN DIMENSIONS			ANGULAR ±1/2°		SEE TABLE		SD-76055-002		2 OF 3		
THIS DRAWING CONTAINS INFORMATION THAT IS PROPRIETARY TO MOLEX INCORPORATED AND SHOULD NOT BE USED WITHOUT WRITTEN PERMISSION											

IMPACT 5 PAIR
BOARD RELATIONSHIPS

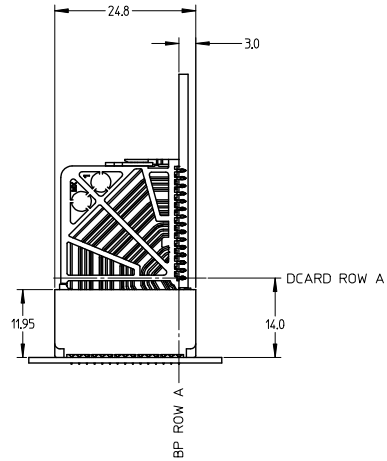
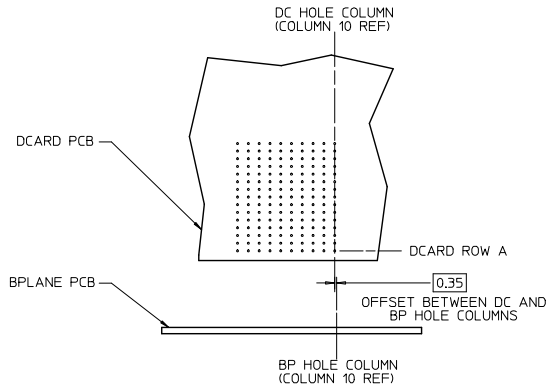
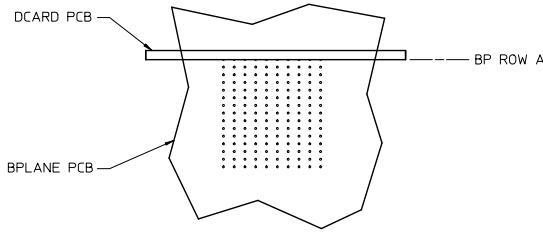

SEE SHEET 1 EC NO: UCP2013-2078 DRAWN BY: BARRA 2012/11/28 CHECKED BY: INGHAM 2012/12/18 APPROVED BY: MILLER 2012/12/31	QUALITY SYMBOLS ∇=0 ∇=0 ∇=0	GENERAL TOLERANCES (UNLESS SPECIFIED)		DIMENSION STYLE MM ONLY		SCALE 2:1	DESIGN UNITS METRIC	THIRD ANGLE PROJECTION	
			mm	INCH	DRAWN BY MSANDBERG	DATE 05/24/2007	TITLE IMPACT 5 PAIR HEADER LEFT GUIDED ASSEMBLY SALES DRAWING		
		4 PLACES ±	---	---	CHECKED BY JLAURX	DATE 05/24/2007	molex DOCUMENT NO. SD-76055-002 SHEET NO. 3 OF 3		
		3 PLACES ±	---	---	APPROVED BY JLAURX	DATE 2010/10/15			
2 PLACES ±	0.13	---	ANGULAR ±1/2°		MATERIAL NO.		SIZE C		
1 PLACE ±	0.25	---	DRAFT WHERE APPLICABLE MUST REMAIN WITHIN DIMENSIONS		THIS DRAWING CONTAINS INFORMATION THAT IS PROPRIETARY TO MOLEX INCORPORATED AND SHOULD NOT BE USED WITHOUT WRITTEN PERMISSION				
0 PLACE ±		---							