

Excellent Integrated System Limited

Stocking Distributor

Click to view price, real time Inventory, Delivery & Lifecycle Information:

[STMicroelectronics](#)
[STEVAL-ISB012V1](#)

For any questions, you can email us directly:

sales@integrated-circuit.com



STEVAL-ISB012V1

Battery monitoring system demonstration board based on the STC3105

Data brief

Features

- The STC3105 device uses the Coulomb counter method to track state-of-charge (SOC) or to track when the battery is charging or discharging
- Accurate measurements of the battery voltage to estimate the battery state-of-charge
- Battery parameters are sent to the PC via USB using a virtual COM port and can be observed using HyperTerminal as well as a GUI
- The board can also display parameters on the LCD
- Charging and discharging status is displayed by the + and - sign respectively on both the LCD and LED
- The board also shows low voltage and SOC alarms
- The board can monitor a battery with a capacity up to +/-10950 mAh
- RoHS compliant

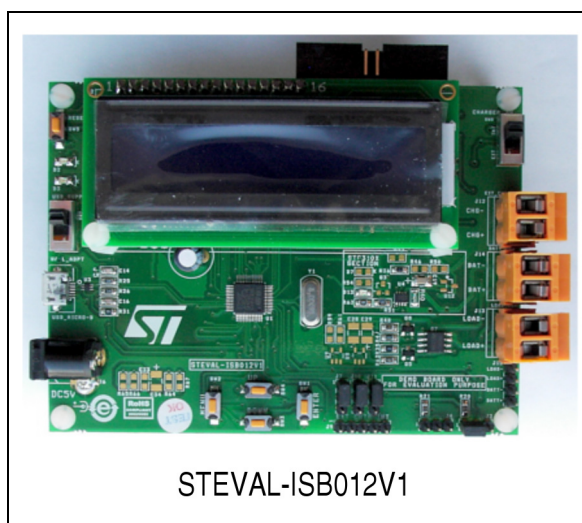

Description

The STEVAL-ISB012V1 demonstration board provides a simple, compact solution to monitor voltage, current, and capacity of single cell Li-Ion batteries using the STC3105, which has a highly efficient gas gauge.

The STEVAL-ISB012V1 demonstration board has an internal charger in order to charge the battery and can be powered through a USB port or by using a DC adaptor.

Circuit schematic

STEVAL-ISB012V1

1 Circuit schematic

Figure 1. Circuit schematic (1 of 3)

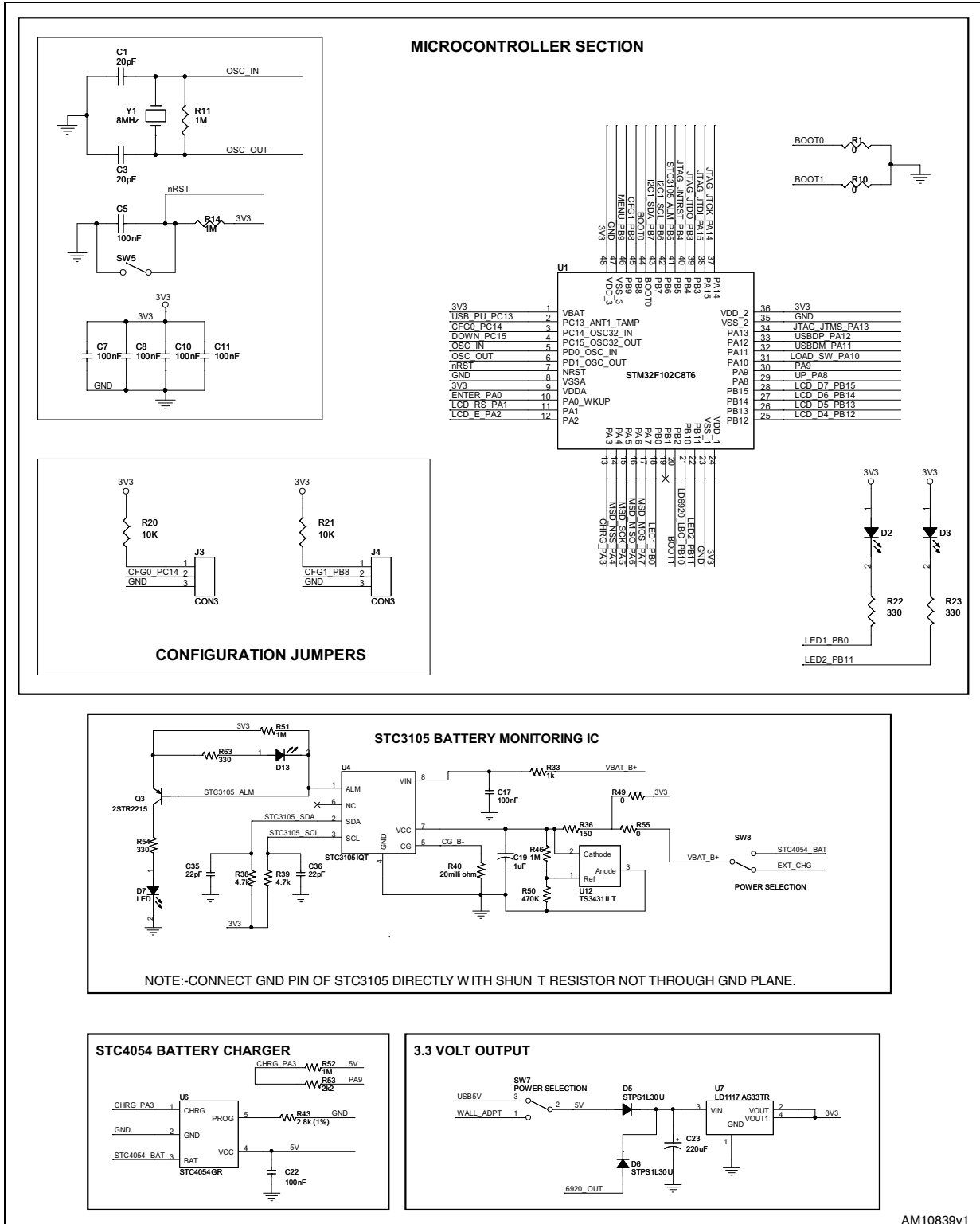

AM10839v1

STEVAL-ISB012V1

Circuit schematic

Figure 2. Circuit schematic (2 of 3)

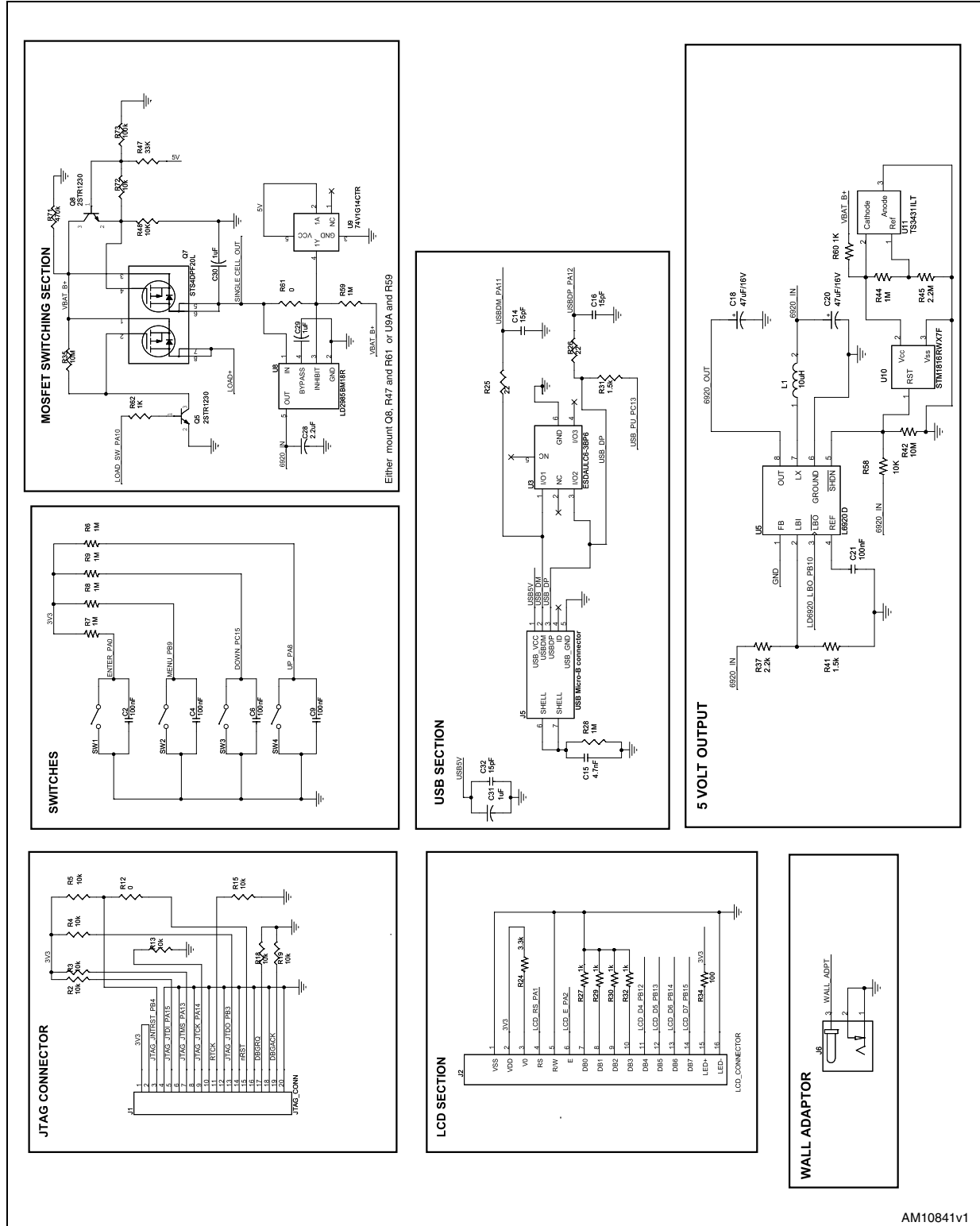

AM10841v1

Circuit schematic

STEVAL-ISB012V1

Figure 3. Circuit schematic (3 of 3)

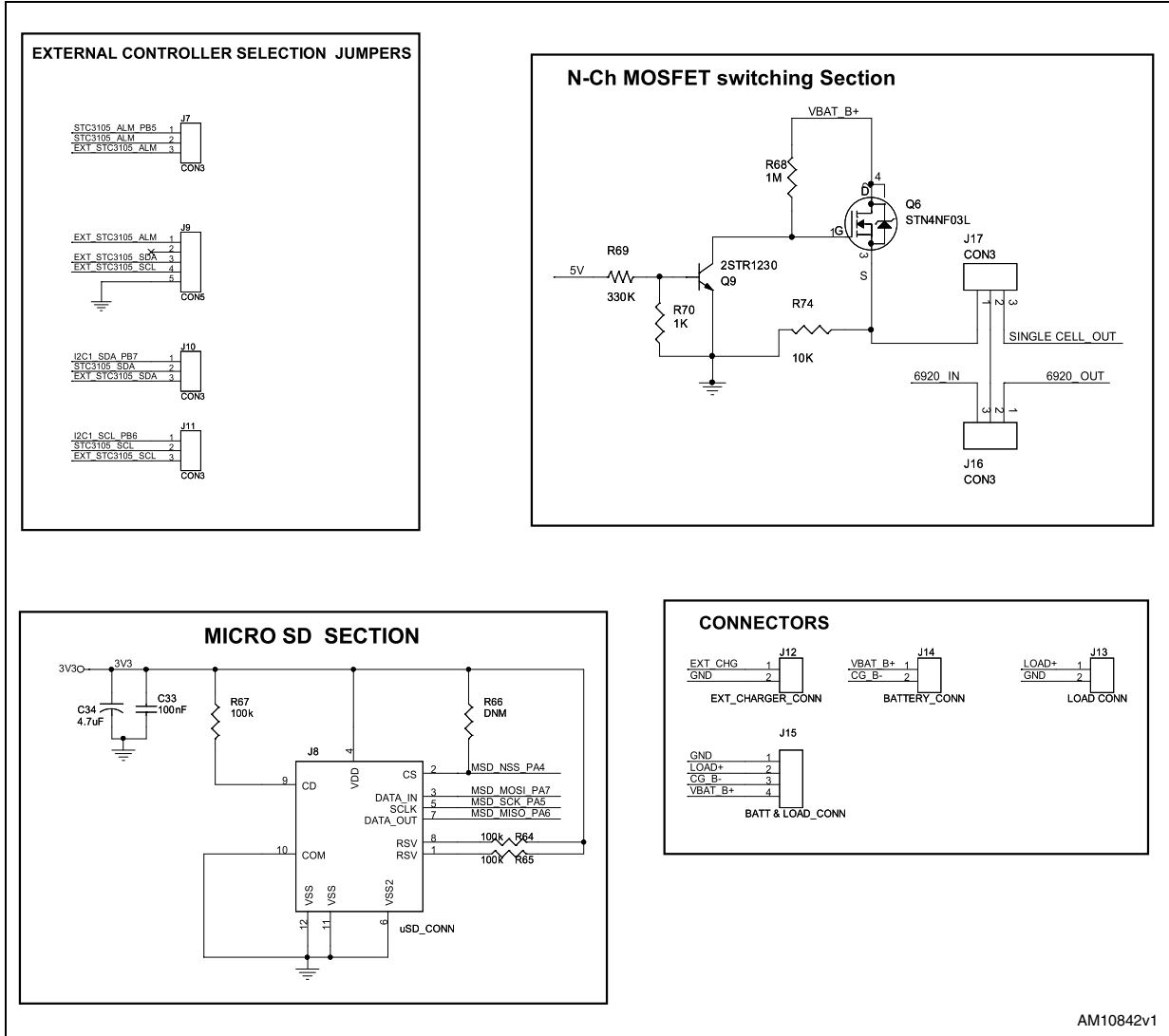

AM10842v1

2 Revision history

Table 1. Document revision history

Date	Revision	Changes
23-Nov-2011	1	Initial release.

STEVAL-ISB012V1

Please Read Carefully:

Information in this document is provided solely in connection with ST products. STMicroelectronics NV and its subsidiaries ("ST") reserve the right to make changes, corrections, modifications or improvements, to this document, and the products and services described herein at any time, without notice.

All ST products are sold pursuant to ST's terms and conditions of sale.

Purchasers are solely responsible for the choice, selection and use of the ST products and services described herein, and ST assumes no liability whatsoever relating to the choice, selection or use of the ST products and services described herein.

No license, express or implied, by estoppel or otherwise, to any intellectual property rights is granted under this document. If any part of this document refers to any third party products or services it shall not be deemed a license grant by ST for the use of such third party products or services, or any intellectual property contained therein or considered as a warranty covering the use in any manner whatsoever of such third party products or services or any intellectual property contained therein.

UNLESS OTHERWISE SET FORTH IN ST'S TERMS AND CONDITIONS OF SALE ST DISCLAIMS ANY EXPRESS OR IMPLIED WARRANTY WITH RESPECT TO THE USE AND/OR SALE OF ST PRODUCTS INCLUDING WITHOUT LIMITATION IMPLIED WARRANTIES OF MERCHANTABILITY, FITNESS FOR A PARTICULAR PURPOSE (AND THEIR EQUIVALENTS UNDER THE LAWS OF ANY JURISDICTION), OR INFRINGEMENT OF ANY PATENT, COPYRIGHT OR OTHER INTELLECTUAL PROPERTY RIGHT.

UNLESS EXPRESSLY APPROVED IN WRITING BY TWO AUTHORIZED ST REPRESENTATIVES, ST PRODUCTS ARE NOT RECOMMENDED, AUTHORIZED OR WARRANTED FOR USE IN MILITARY, AIR CRAFT, SPACE, LIFE SAVING, OR LIFE SUSTAINING APPLICATIONS, NOR IN PRODUCTS OR SYSTEMS WHERE FAILURE OR MALFUNCTION MAY RESULT IN PERSONAL INJURY, DEATH, OR SEVERE PROPERTY OR ENVIRONMENTAL DAMAGE. ST PRODUCTS WHICH ARE NOT SPECIFIED AS "AUTOMOTIVE GRADE" MAY ONLY BE USED IN AUTOMOTIVE APPLICATIONS AT USER'S OWN RISK.

Resale of ST products with provisions different from the statements and/or technical features set forth in this document shall immediately void any warranty granted by ST for the ST product or service described herein and shall not create or extend in any manner whatsoever, any liability of ST.

ST and the ST logo are trademarks or registered trademarks of ST in various countries.

Information in this document supersedes and replaces all information previously supplied.

The ST logo is a registered trademark of STMicroelectronics. All other names are the property of their respective owners.

© 2011 STMicroelectronics - All rights reserved

STMicroelectronics group of companies

Australia - Belgium - Brazil - Canada - China - Czech Republic - Finland - France - Germany - Hong Kong - India - Israel - Italy - Japan - Malaysia - Malta - Morocco - Philippines - Singapore - Spain - Sweden - Switzerland - United Kingdom - United States of America

www.st.com