



Distributor of Molex Connector Corporation: Excellent Integrated System Limited
Datasheet of 0192770008 - Connector Quick Connect Receptacle 10-12 AWG 0.250"
(6.35mm) Crimp

Contact us: sales@integrated-circuit.com Website: www.integrated-circuit.com

Excellent Integrated System Limited

Stocking Distributor

Click to view price, real time Inventory, Delivery & Lifecycle Information:

[Molex Connector Corporation](#)
[0192770008](#)

For any questions, you can email us directly:
sales@integrated-circuit.com

MATERIAL NUMBER LOOSE PCS	ENGINEERING NUMBER LOOSE PCS	MATERIAL NUMBER ON STRIP	ENGINEERING NUMBER ON STRIP	MATERIAL NUMBER ON TAPE	ENGINEERING NUMBER ON TAPE	ACCEPTS TAB SIZE	STOCK THK REF	OD MAX	ID MIN	MWID	"A" MAX	"B" MAX	"G" MAX	"H" REF
192770002	AA-5261-LIF	192770001	AA-5261Z-LIF	192770003	AA-5261T-LIF	.250 X .032	.016/0.41	.19/4.8	.056/1.42	.12/3.0	.89/22.6	.38/9.7	.20/5.1	1.43/36.2
192770005	BB-5263-LIF	192770004	BB-5263Z-LIF	192770006	BB-5263T-LIF	.250 X .032	.016/0.41	.22/5.6	.079/2.00	.14/3.6	.89/22.6	.38/9.7	.20/5.1	1.43/36.2
192770008	C-5293-LIF	192770007	C-5293Z-LIF	192770009	C-5293T-LIF	.250 X .032	.018/0.46	.32/8.1	.117/2.97	.23/5.8	1.02/25.9	.39/9.9	.24/6.1	1.51/38.4

Contact us: Sales@integrated-circuit.com Website: www.integrated-circuit.com

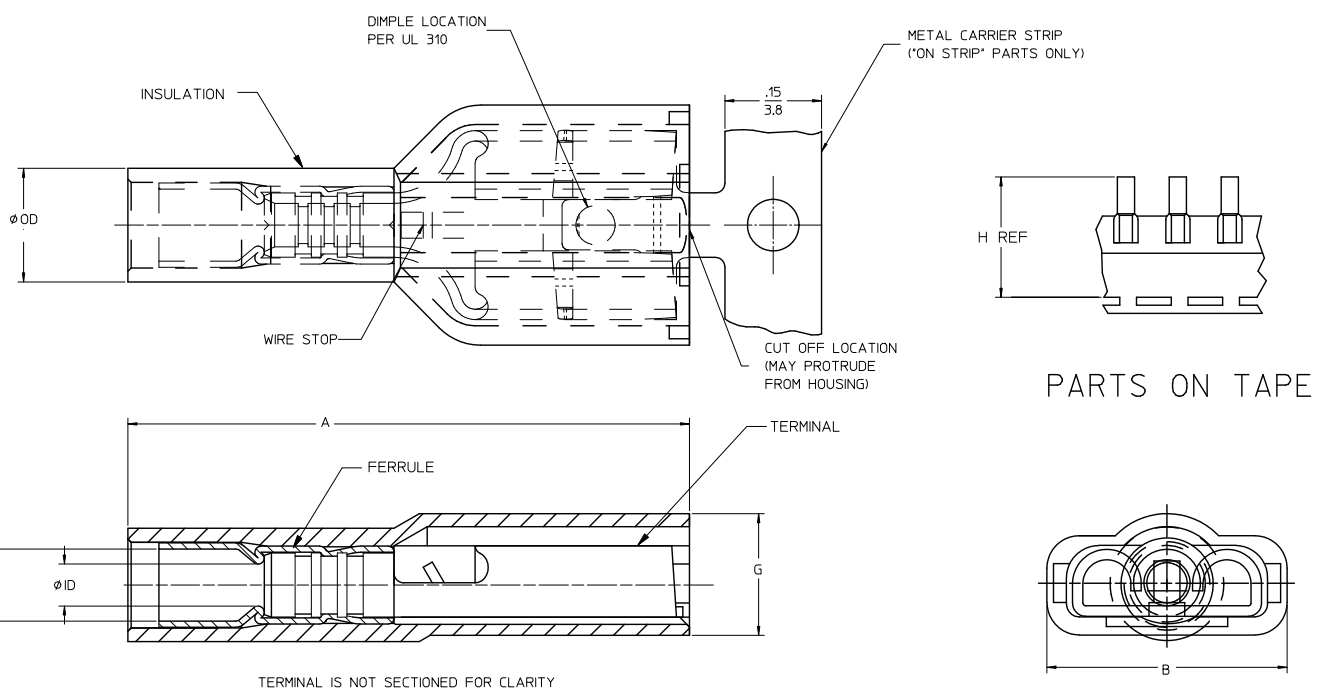

TERMINAL IS NOT SECTIONED FOR CLARITY

SALES DRAWING

NOTES:

- MATERIALS:
 TERMINAL: MATTE-TIN PLATED BRASS
 FERRULE: MATTE-TIN PLATED COPPER ALLOY
 INSULATION: NYLON 6/6 94V-2,
 SEE CHART FOR COLORS
- PRODUCT SPECIFICATION: PS-19902-012
- MWID = MAXIMUM WIRE INSULATION DIAMETER
- PARTS ARE ROHS COMPLIANT

RELEASE EC NO: WNA2009-0761 DRW: ETHRODAHL 2010/03/17 CHKD: JMACNEIL 2010/03/17 APPR: JMACNEIL 2011/01/06	QUALITY SYMBOLS ▽=0 ▽=0	GENERAL TOLERANCES (UNLESS SPECIFIED)		DIMENSION STYLE		SCALE	DESIGN UNITS	THIRD ANGLE PROJECTION	
		mm	INCH	IN/MM		1:1	INCH		
		4 PLACES ±---	±---	DRAWN BY	DATE	TITLE			
		3 PLACES ±---	±.005	ETHRODAHL	2010/03/17	QUIXON LOW INSERT FORCE FULLY INSUL QUICK DISCNT AVIKRIMP 22-10 AWG			
2 PLACES ±0.13	±.010	JMACNEIL	2010/03/17	APPROVED BY		DATE	MOLEX INCORPORATED		
1 PLACE ±0.25	±.020	JMACNEIL	2011/01/06	MATERIAL NO.		DOCUMENT NO.	SHEET NO.		
DRAFT WHERE APPLICABLE MUST REMAIN WITHIN DIMENSIONS		SEE CHART		SD-19277-001		1 OF 1			
THIS DRAWING CONTAINS INFORMATION THAT IS PROPRIETARY TO MOLEX INCORPORATED AND SHOULD NOT BE USED WITHOUT WRITTEN PERMISSION									