

## Excellent Integrated System Limited

Stocking Distributor

Click to view price, real time Inventory, Delivery & Lifecycle Information:

[E-Switch](#)  
[RP3502MAYEL](#)

For any questions, you can email us directly:

[sales@integrated-circuit.com](mailto:sales@integrated-circuit.com)

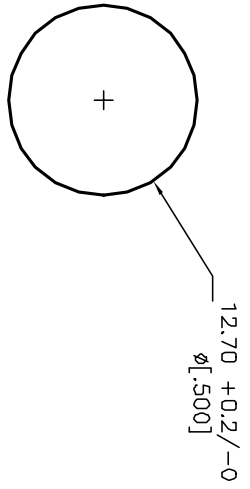

RECOMMENDED PANEL  
MOUNTING

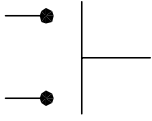

CIRCUIT: 2P: SPST  
CONTACT CONFIGURATION  
OFF (ON)

NOTES:

1. ALL DIMENSIONS IN MM [INCH]
2. GENERAL TOLERANCE: X.X=±0.4  
X.XX=±0.25
3. TERM. NOS. FOR REF. ONLY
4. RATING: 3A 125V, 1.5A 250V AC
5. CONTACT RESISTANCE: 50m ohm max.
6. INSULATION RESISTANCE: DC 500V 100M ohm min.
7. DIELECTRIC STRENGTHS: AC 1000V 1 minute
8. ACTUATOR COLOR: YELLOW

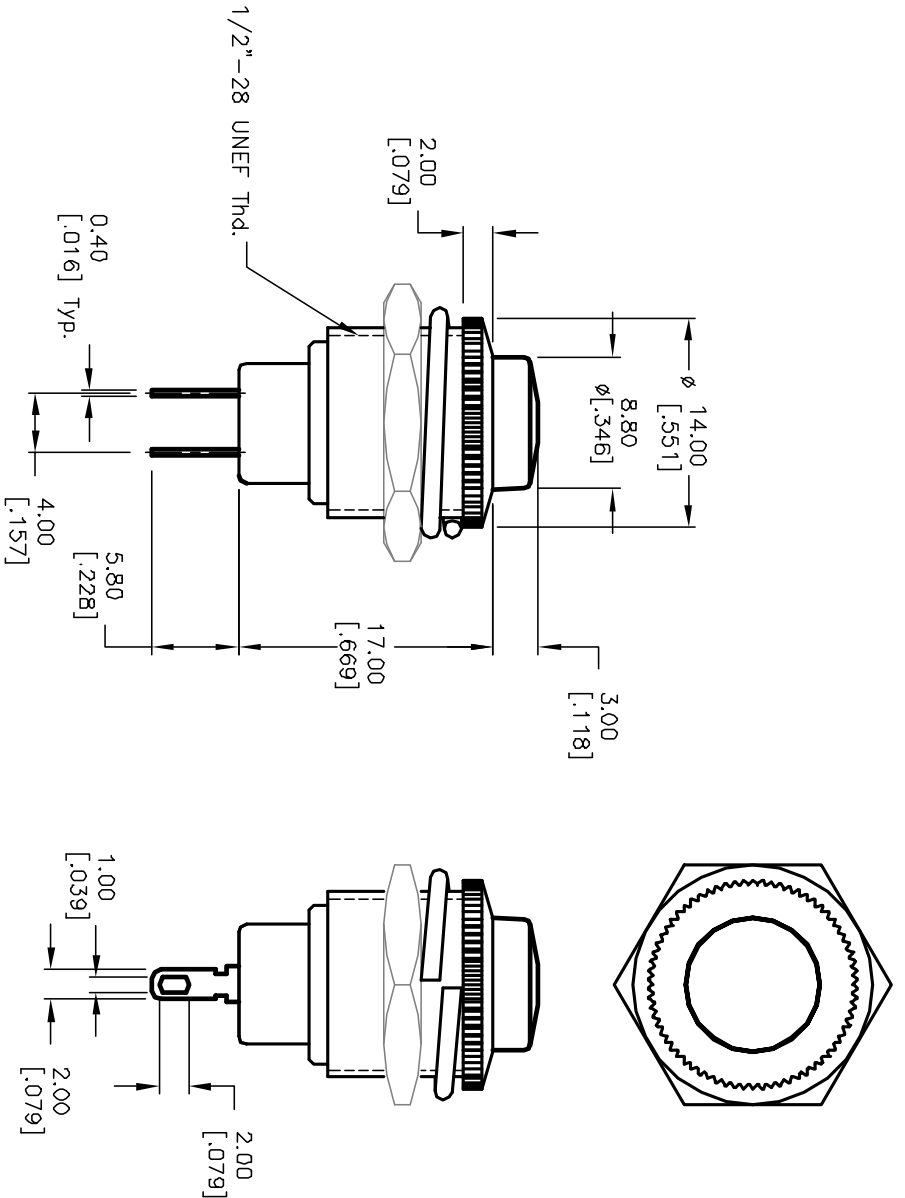

**E-SWITCH®**

RP3502MA-YEL

REV.	ECN No.	DESCRIPTION	DATE	CHKD
A	12156	REFER TO OLD TAB# F030015_A	5/21/00	CB

THE INFORMATION CONTAINED IN THIS DOCUMENT IS PROPRIETARY TO E-SWITCH AND IS NOT TO BE COPIED OR TRANSMITTED

TITLE	SCALE	DATE	DR	DWG	REV
RP3502MA-YEL	2:1	2/14/00	MM	F030017	A