

Excellent Integrated System Limited

Stocking Distributor

Click to view price, real time Inventory, Delivery & Lifecycle Information:

[Panasonic Electronic Components](#)
[LN28RALUS](#)

For any questions, you can email us directly:

sales@integrated-circuit.com

超高輝度 GaAlAs

Ultra Bright GaAlAs Lamps

丸形 Round Type
φ 3.0mm Series

Type No. Lighting Color
 LN28RAL(US)Red
 LN28RCAL(US)Red
 LN28WAL(US)Red
 LN28CAL(US)Red

絶対最大定格 Absolute Maximum Ratings (Ta=25 °C)

Lighting Color	P _D (mW)	I _F (mA)	I _{FP} (mA)*	V _R (V)	T _{opr} (°C)	T _{stg} (°C)
Red	70	30	150	3	-25~+85	-30~+100

* I_{FP}の条件は、duty 10%, Pulse width 1 msec. The condition of I_{FP} is duty 10%, Pulse width 1 msec

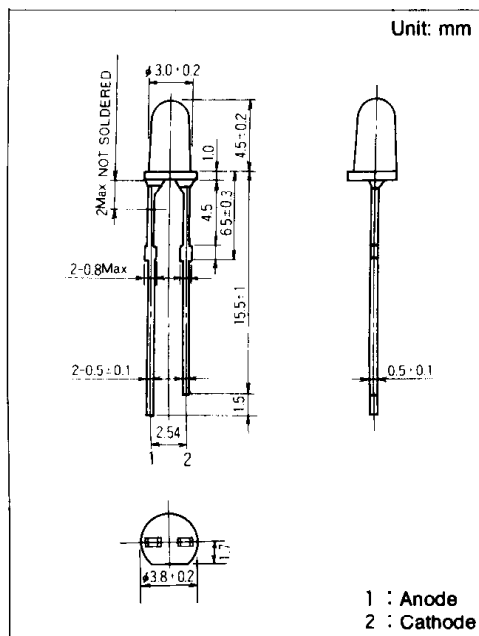

電気的光学的特性 Electro-Optical Characteristics (Ta=25 °C)

Type No.	Lighting Color	Lens Color	I ₀			V _F		λ _P	Δλ	I _F	I _R	
			Typ.	Min.	I _F	Typ.	Max.				Max.	V _R
LN28RAL(US)	Red	Red Diffused	25	10	20	1.8	2.6	665	20	20	100	3
LN28RCAL(US)	Red	Red Clear	85	—	20	1.8	2.6	665	20	20	100	3
LN28WAL(US)	Red	White Diffused	50	—	20	1.8	2.6	665	20	20	100	3
LN28CAL(US)	Red	Clear	85	30	20	1.8	2.6	665	20	20	100	3
Unit	—	—	mcd	mcd	mA	V	V	nm	nm	mA	μA	V

